

# 1530L260

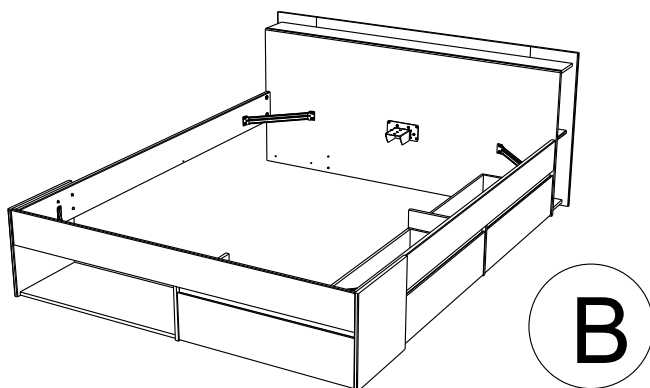
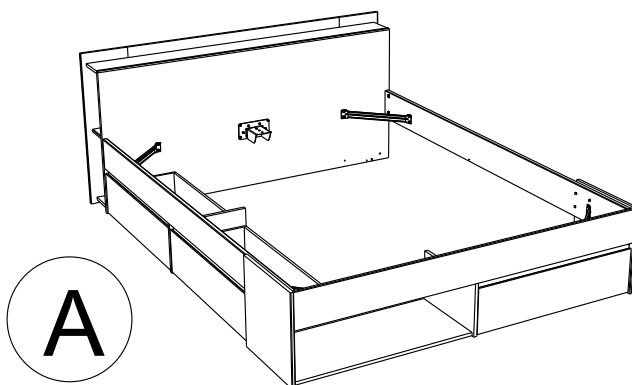

## FR Remerciements :

Nous vous remercions d'avoir choisi un meuble créé et fabriqué par le Groupe Parisot et espérons qu'il vous donnera entière satisfaction.

## EN Thanks:

Thank you for choosing furniture designed and manufactured by the Parisot Group. We hope you are totally satisfied with your purchase.

## DE Danksagung:

Wir danken Ihnen für den Kauf eines Frankreich von der Parisot-Gruppe entworfenen und hergestellten Möbelstücks und hoffen, dass Sie es zu Ihrer vollkommenen Zufriedenheit finden werden.

## ES Agradecimientos:

Les damos las gracias por haber elegido un mueble diseñado y fabricado por el Groupe Parisot y esperamos que sea de su total agrado.

## PT Agradecimentos:

Obrigado por ter escolhido um móvel concebido e fabricado pelo Grupo Parisot, esperando que seja do seu inteiro agrado.

## IT Ringraziamenti:

Grazie per avere scelto un mobile progettato e fabbricato dal Gruppo Parisot. Speriamo soddisfisi appieno le vostre esigenze.

## NL Bedankje:

Wij bedanken u voor de aankoop van een door de Groep Parisot ontworpen en vervaardigd meubel en hopen dat u er veel plezier aan zult beleven.

## CZ Poděkování:

Děkujeme, že jste si vybrali nábytek navržený a vyrobený společností Parisot Group. Doufáme, že budete svým nákupem naprosto spokojeni.

## HU Köszönet:

Köszönjük, hogy a Parisot Groupe által létrehozott és gyártott bútort választott, reméljük, hogy elégedett lesz a termékkel.

## PL Podziękowania:

Dziękujemy za wybór mebli stworzonych i wyprodukowanych przez Grupę Parisot. Mamy nadzieję, że będziecie Państwo w pełni zadowoleni z zakupem.

## RO Mulțumiri:

Vă mulțumim că ați ales un articol de mobilier conceput și fabricat de Grupul Parisot și sperăm că veți fi pe deplin satisfăcuți de acesta.

## RU Благодарность:

Мы благодарим вас за то, что вы выбрали мебель, созданную и произведенную Групп Паризо, и надеемся, что вы будете полностью удовлетворены нашей продукцией.

## SK Pod'akovanie:

Ďakujeme, že ste si vybrali nábytok navrhnutý a vyrobený spoločnosťou Parisot Group. Dúfame, že budete svojim nákupom absolútne spokojní.

## TR Teşekkür ederiz:

Parisot Group tarafından tasarlanan ve üretilen bu mobilyayı seçtiğiniz için teşekkür ederiz. Ürünümüzden memnun kalmanızı ümit ederiz.

## AR شكر:

نشكركم لاختياركم هذه القطعة من الأثاث من تصميم وتصنيع مجموعة باريسو Parisot ونتمنى أن تتلوا رضاهم.

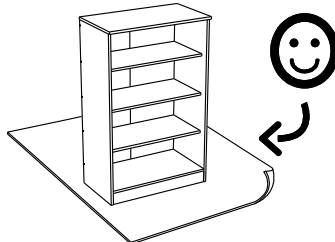
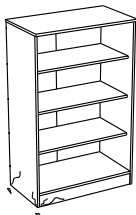
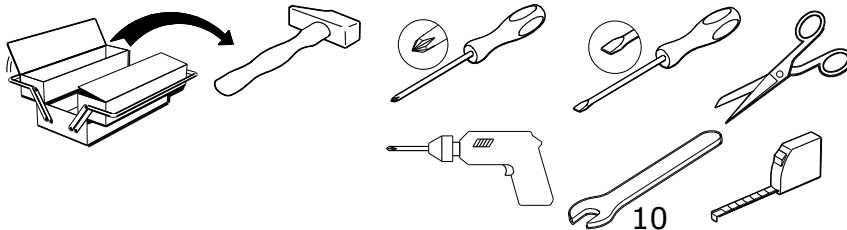

[contact@parisot.com](mailto:contact@parisot.com)

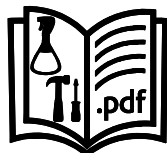

[www.parisot.com](http://www.parisot.com)

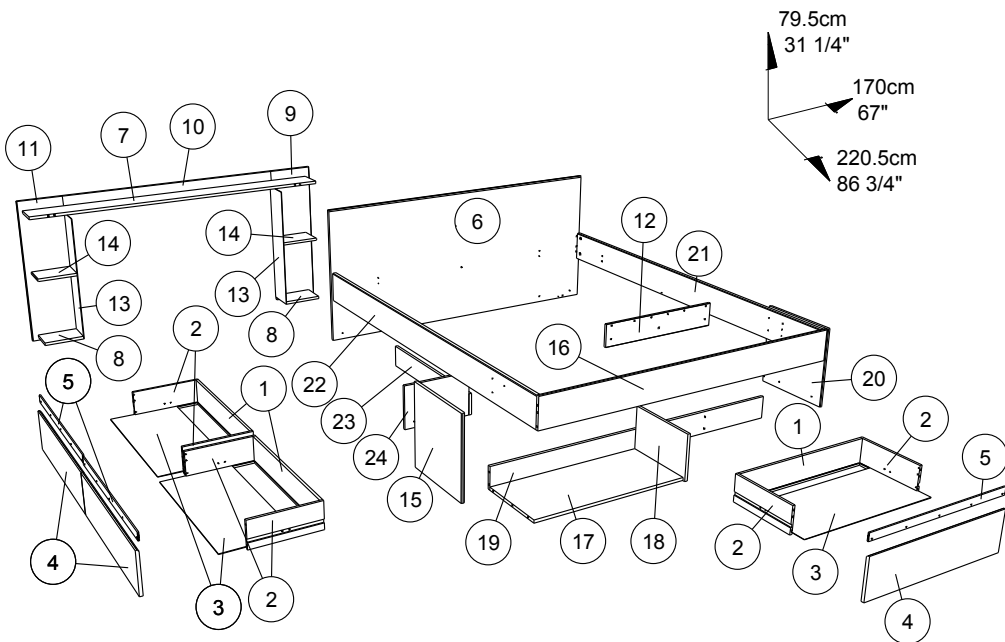

		mm			inch		
8	x 2	210	150	15	8 1/4	5 7/8	9/16
14	x 2	210	150	15	8 1/4	5 7/8	9/16
18	x 1	376	240	15	14 13/16	9 7/16	9/16
24	x 1	376	240	15	14 13/16	9 7/16	9/16
20	x 1	403	398	15	15 7/8	15 11/16	9/16
15	x 1	403	398	15	15 7/8	15 11/16	9/16
12	x 1	600	110	12	23 5/8	4 5/16	1/2
9	x 1	793	244	15	31 1/4	9 5/8	9/16
11	x 1	793	244	15	31 1/4	9 5/8	9/16
5	x 3	800	40	6	31 1/2	1 9/16	1/4
4	x 3	800	208	15	31 1/2	8 3/16	9/16
23	x 1	820	120	15	32 5/16	4 3/4	9/16
17	x 1	825	363	15	32 1/2	14 5/16	9/16
10	x 1	1212	91	15	47 11/16	3 9/16	9/16
19	x 1	1644	120	15	64 3/4	4 3/4	9/16
16	x 1	1644	160	15	64 3/4	6 5/16	9/16
7	x 1	1648	150	15	64 7/8	5 7/8	9/16
6	x 1	1650	740	15	64 15/16	29 1/8	9/16
21	x 1	2000	155	22	78 3/4	6 1/8	7/8
22	x 1	2000	155	22	78 3/4	6 1/8	7/8
2	x 6	350	139	13	13 3/4	5 1/2	1/2
1	x 3	753	139	13	29 5/8	5 1/2	1/2
13	x 2	684	162	3	26 15/16	6 3/8	1/8
3	x 3	764	349	3	30 1/16	13 3/4	1/8

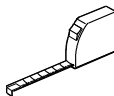

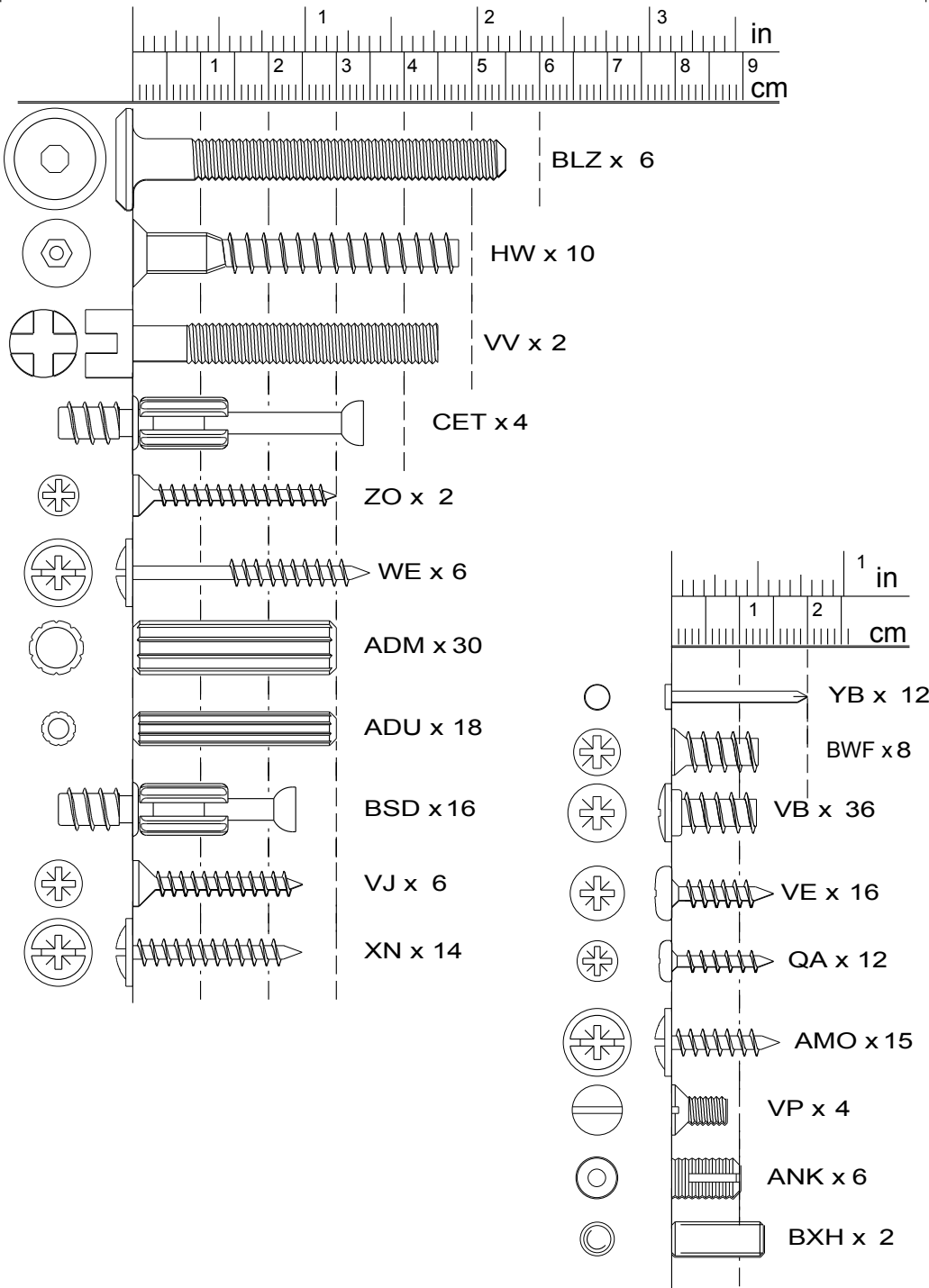



VW x 2



Ai x 20

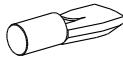

BWD x 8



AHX x 6



EP x 6



UQ x 2



EO x 4



HV x 1

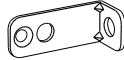

BLL x 11



BLJ x 4

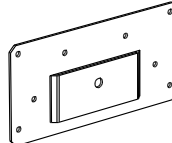

BZC x 2

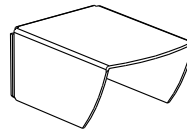

BZD x 2

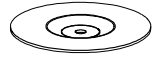

BZN x 1

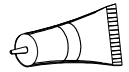

CF x 2

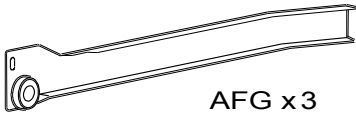

AFG x 3

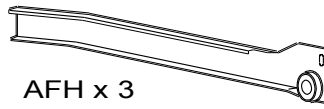

AFH x 3

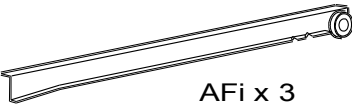

AFi x 3

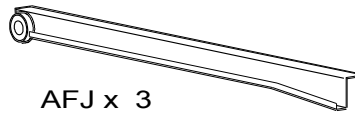

AFJ x 3

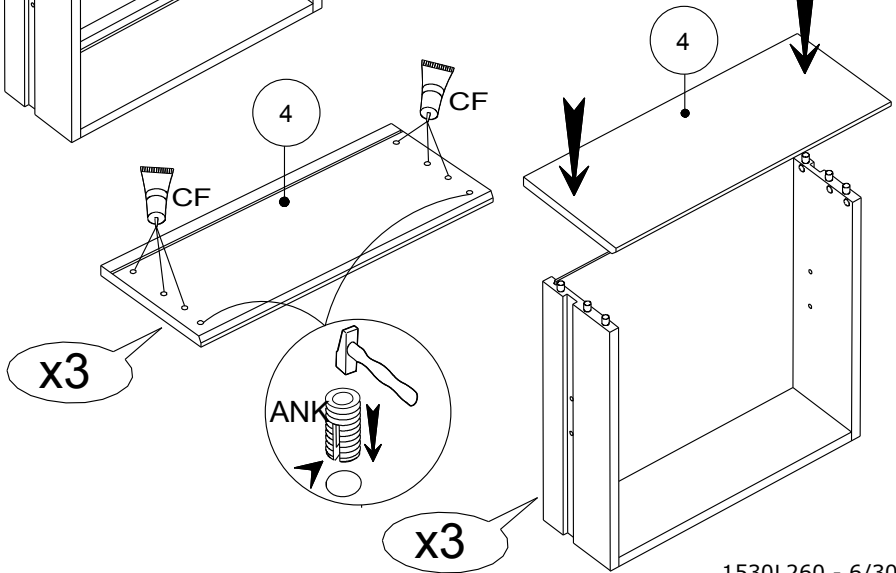
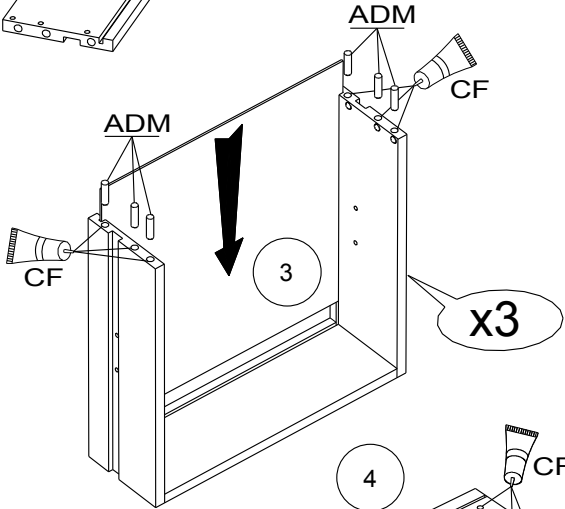
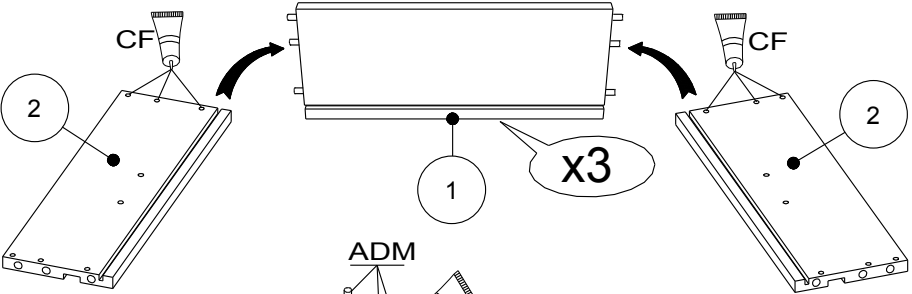
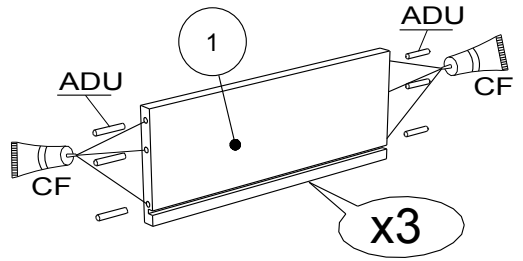
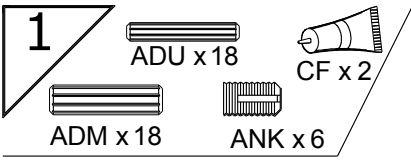

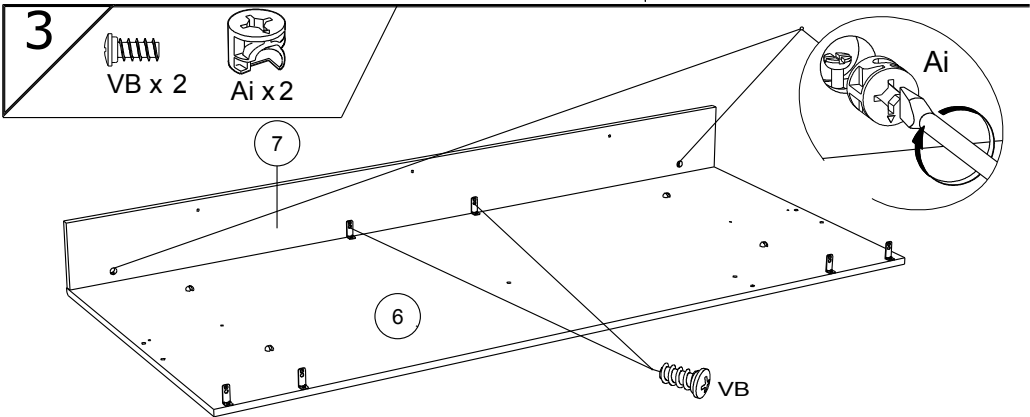
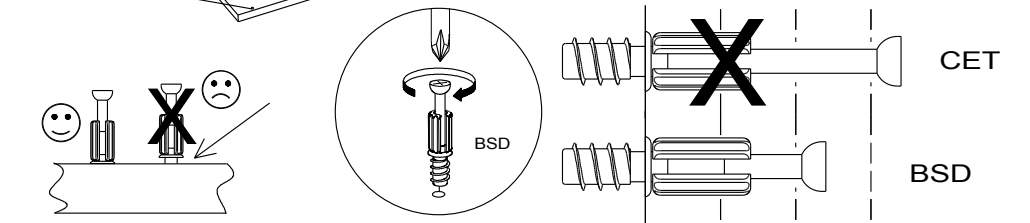
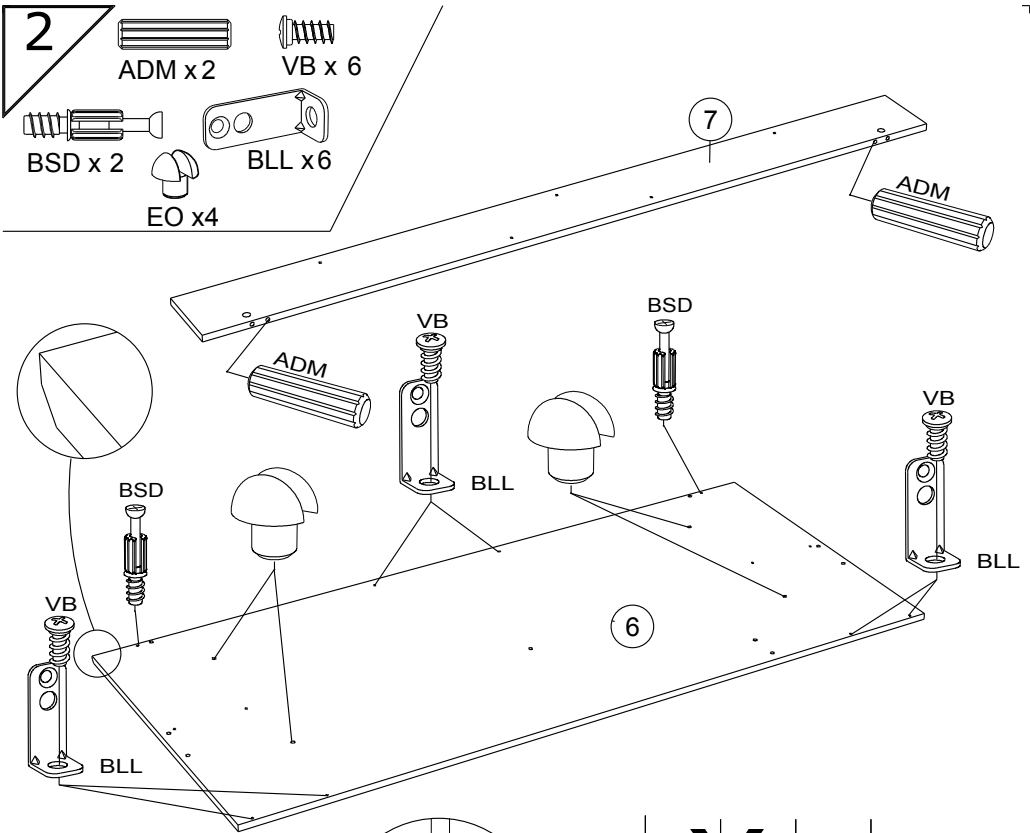

4

VB x 4

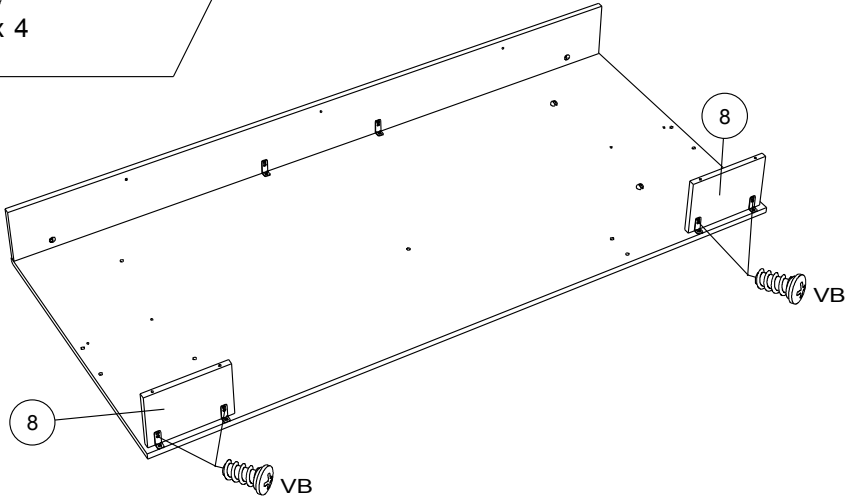

5

ADM x 2

AHX x 2

VV x 2

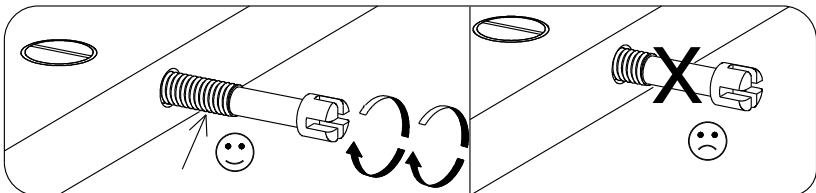
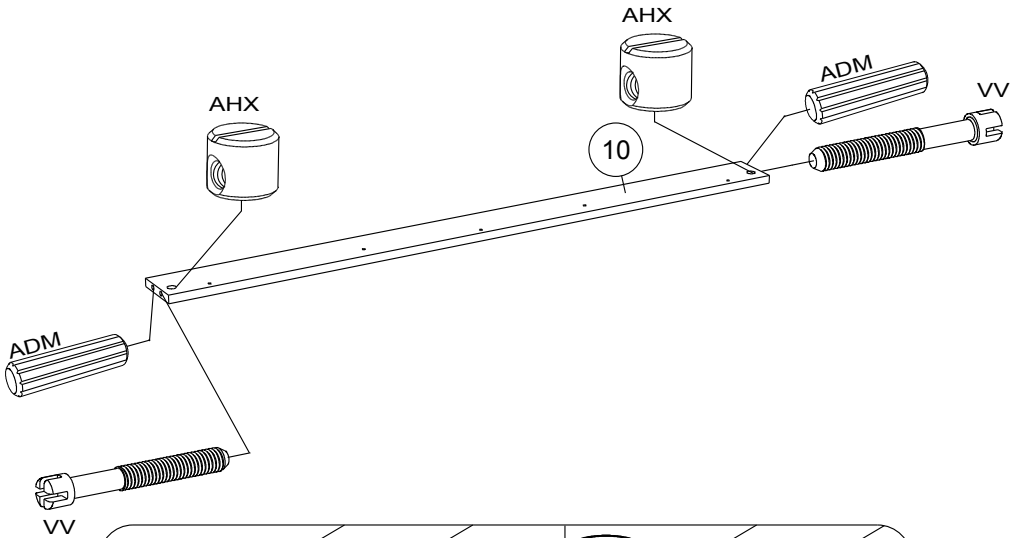



6

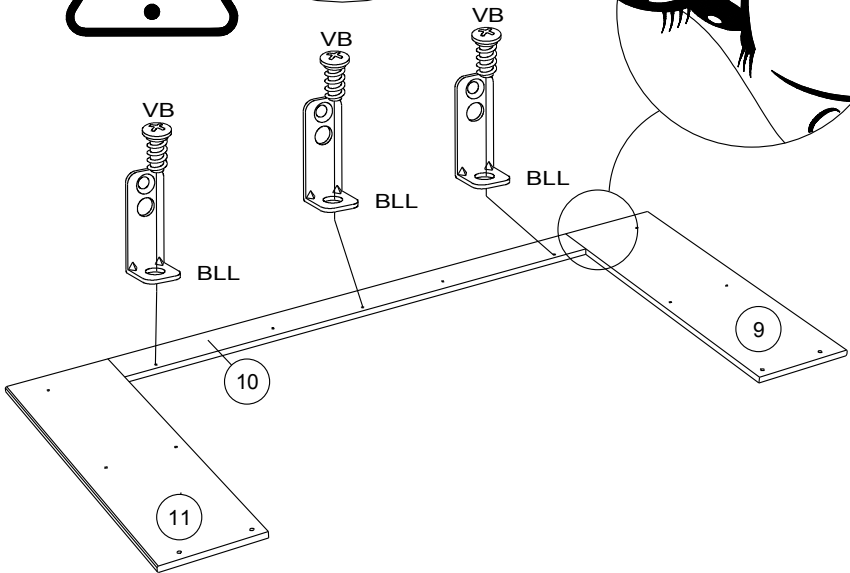
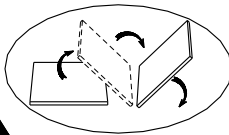
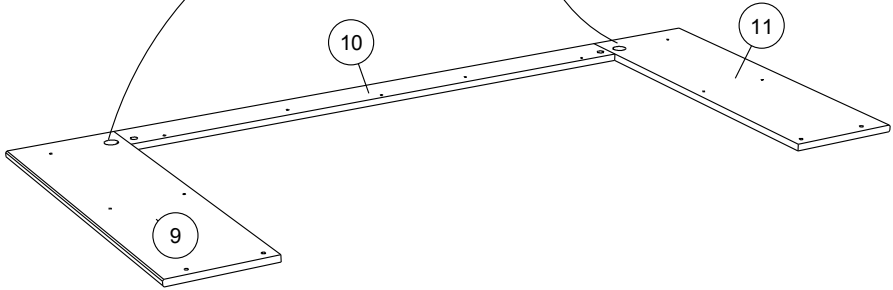
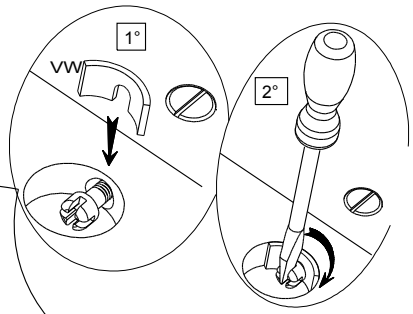
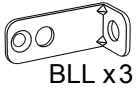

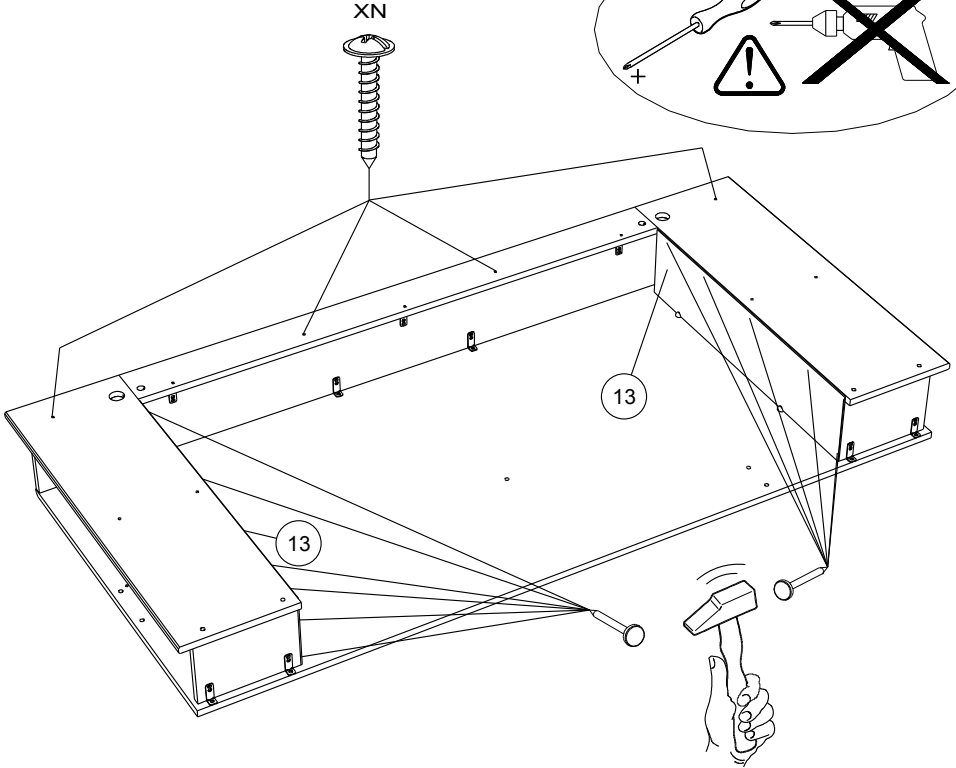
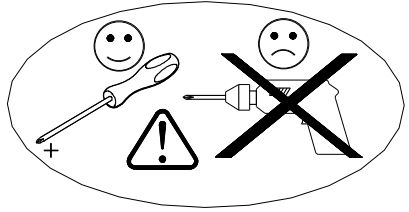
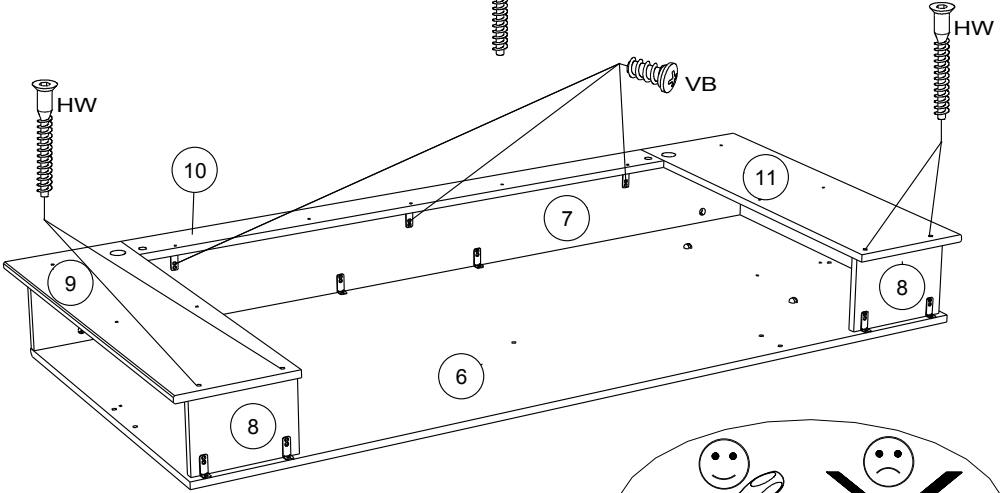
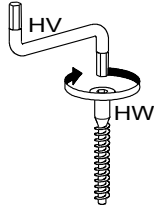
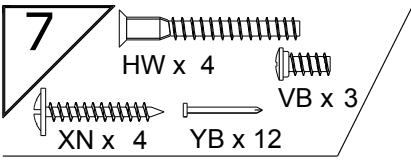

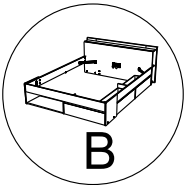
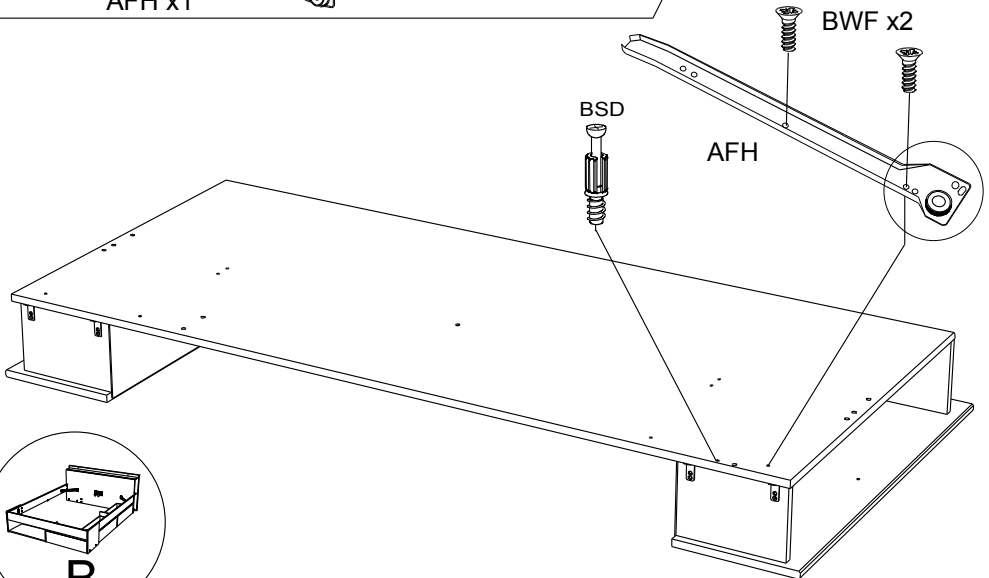
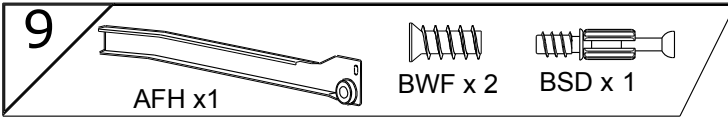
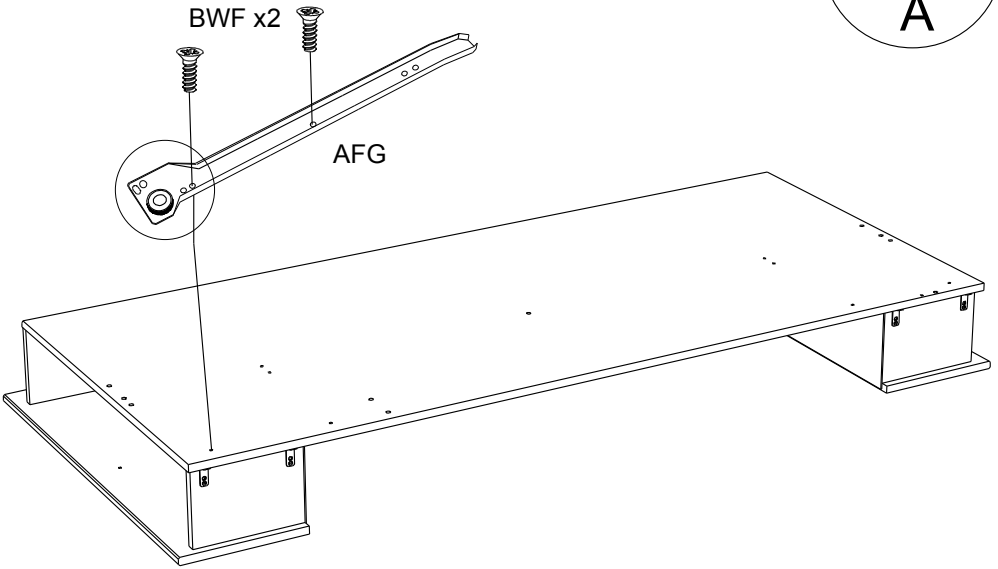
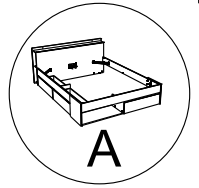
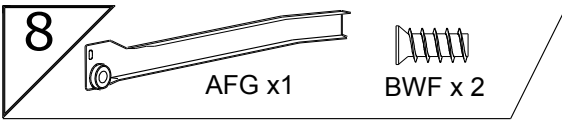

10

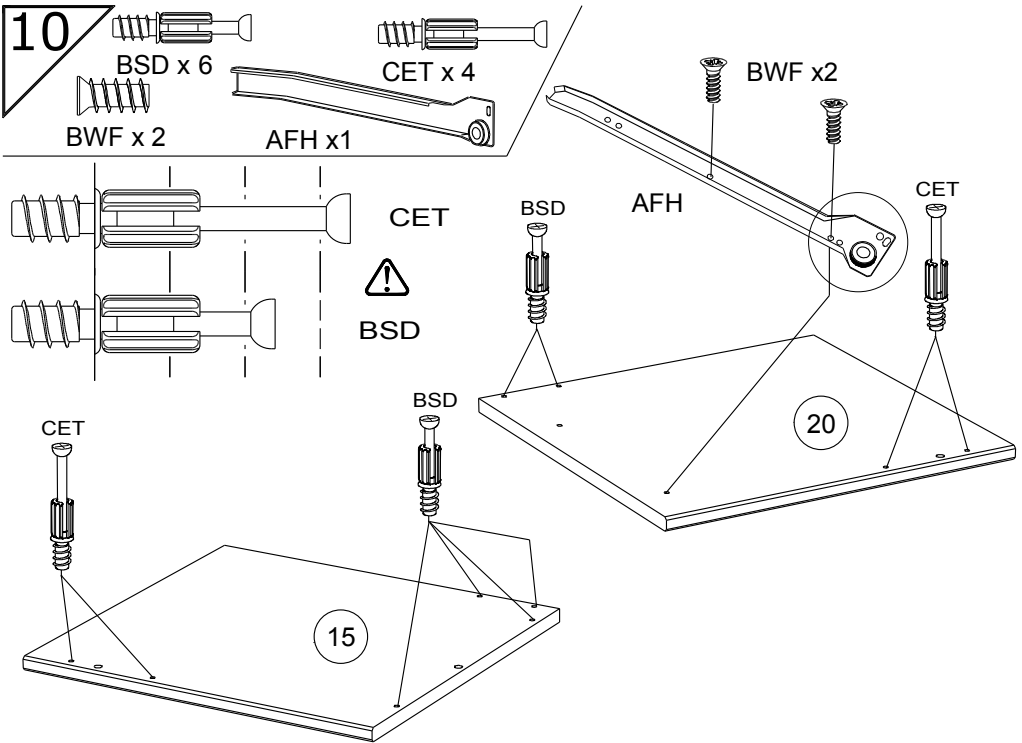

11

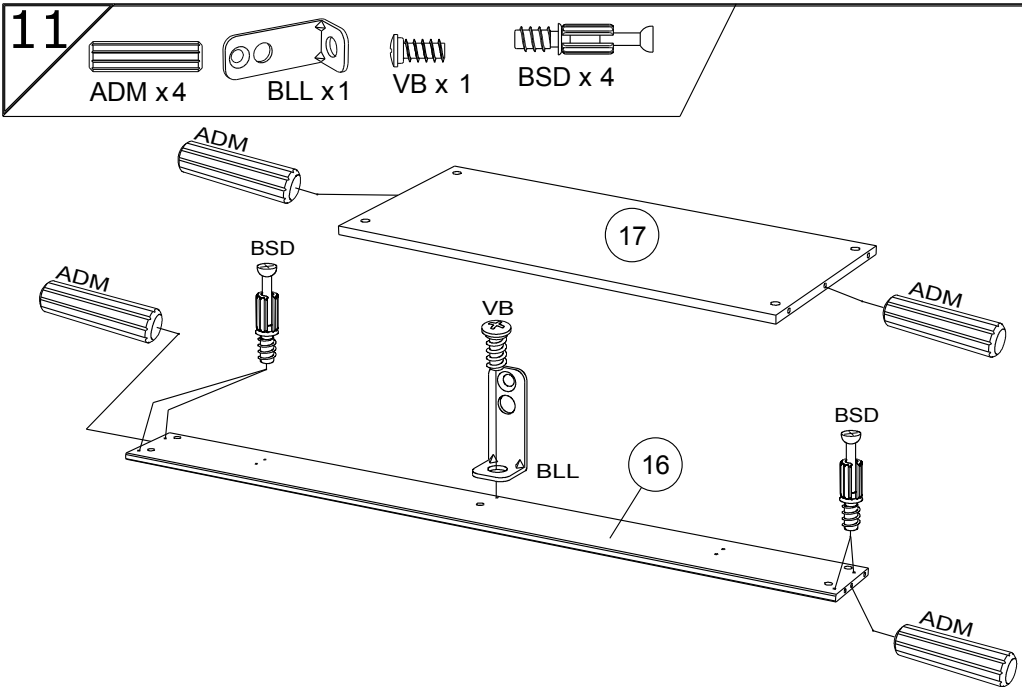

12

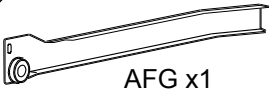

AFG x1



BSD x 2



BWF x 2

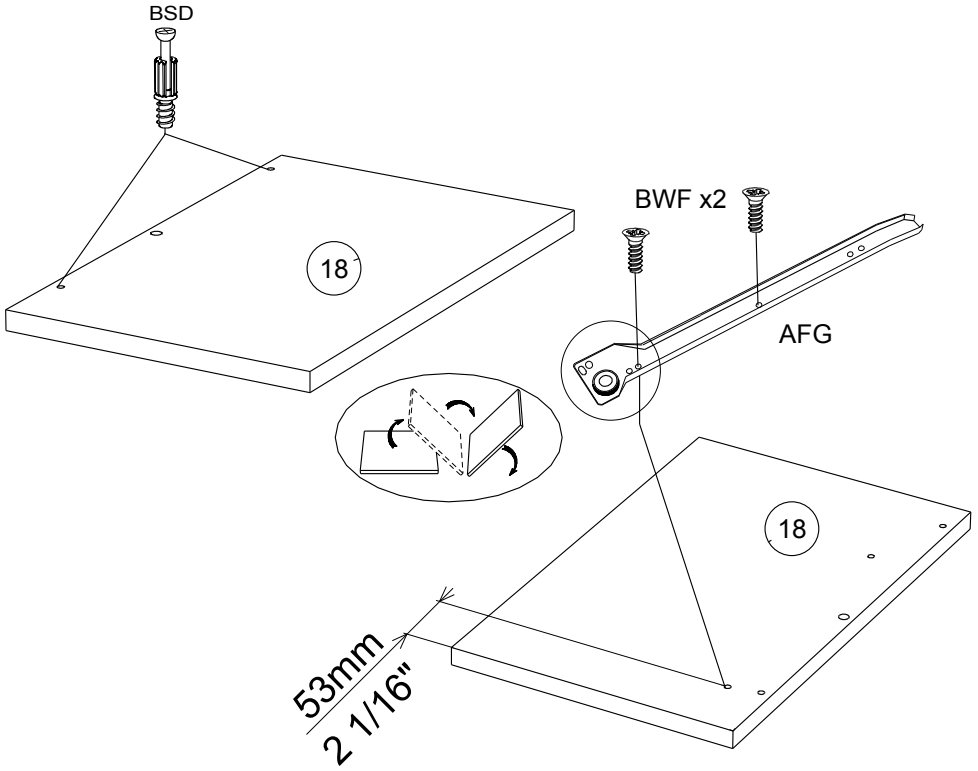

13



Ai x 2

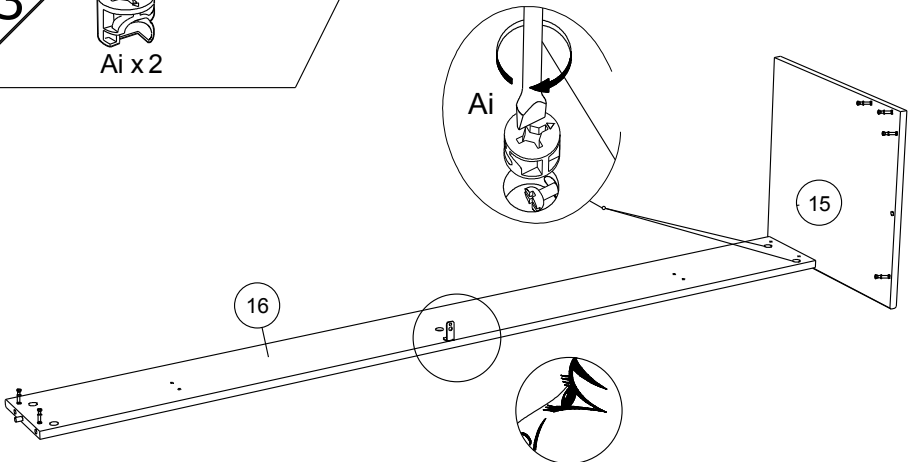

14



Ai x 4

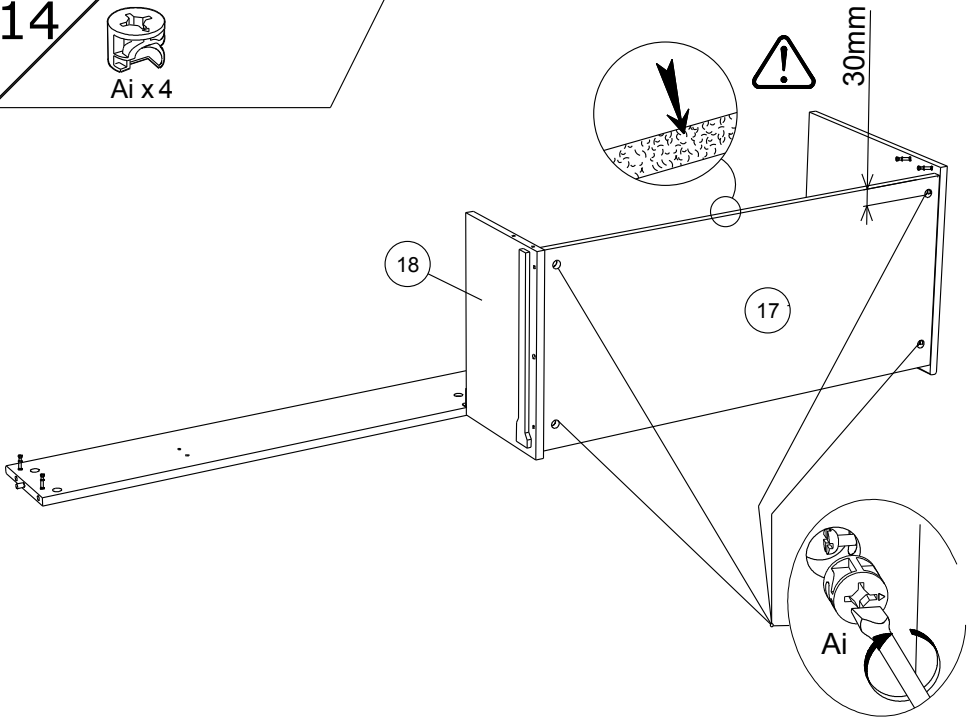

15

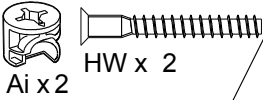

Ai x 2

HW x 2

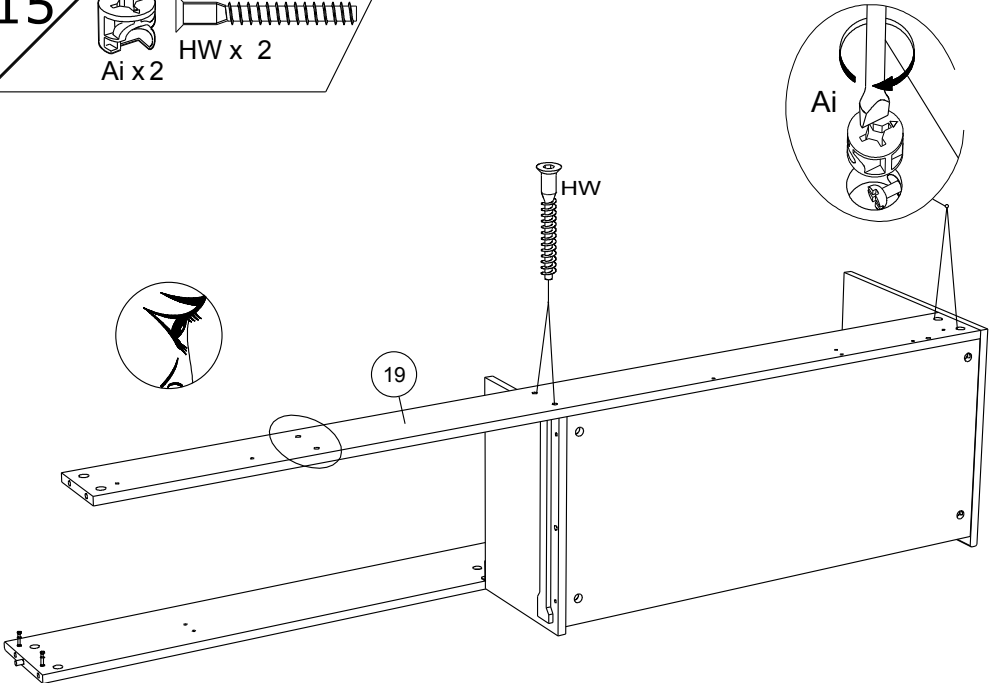

16



Ai x 4

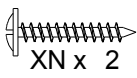

XN x 2

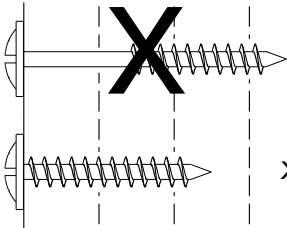
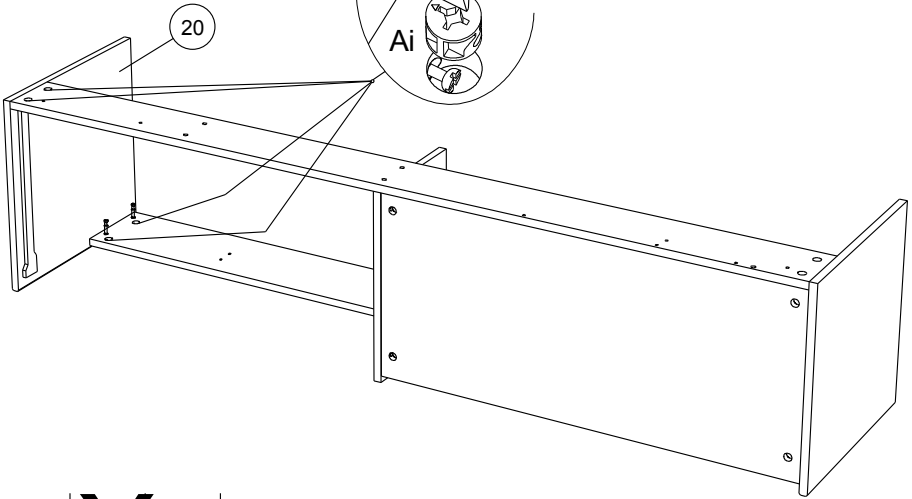

WE



XN

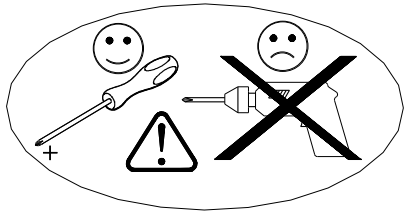

XN

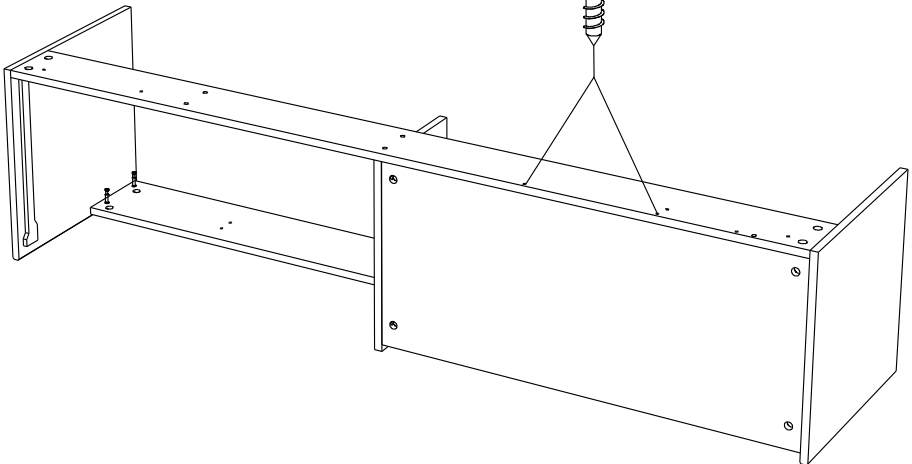

17

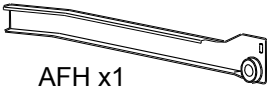

BWF x 2

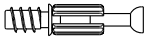

BSD x 1

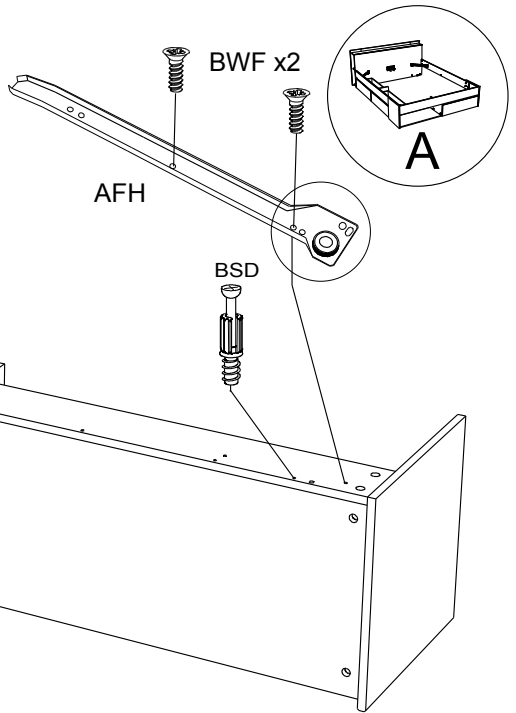

18



BWF x 2



AFG x1

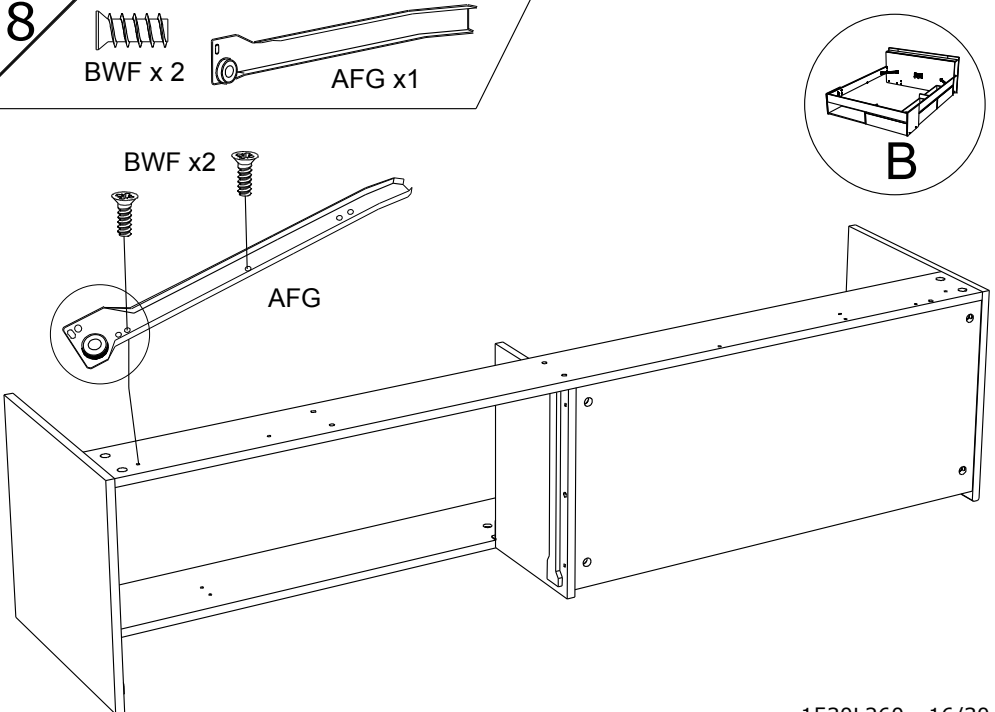





21  
ZO x 1

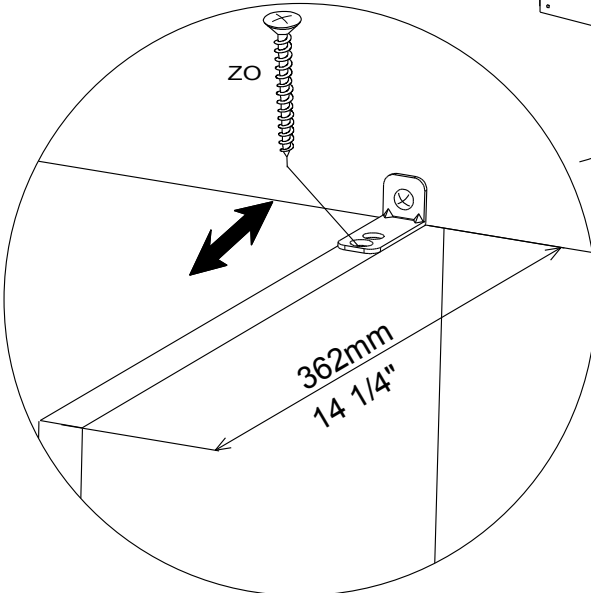
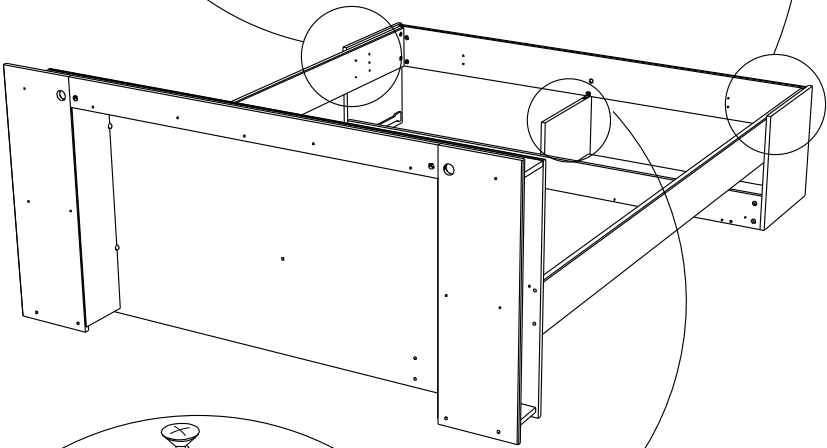
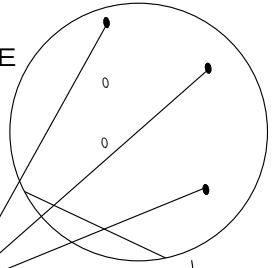
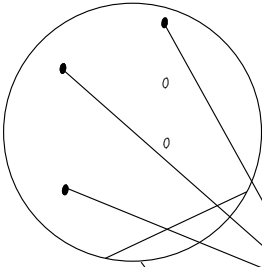
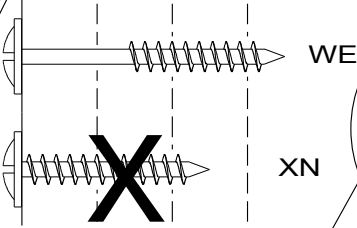
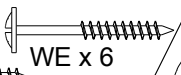

ZO

362mm  
14 1/4"

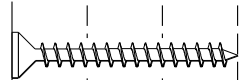

ZO

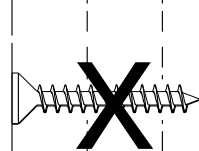

VJ

22

VB x 16

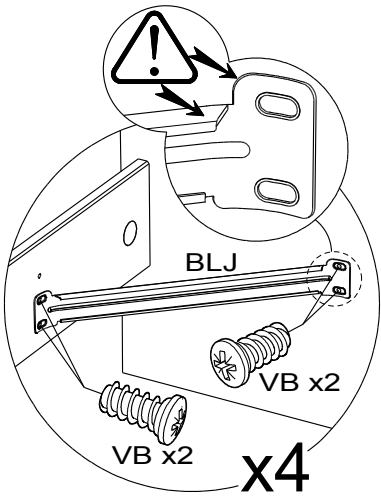
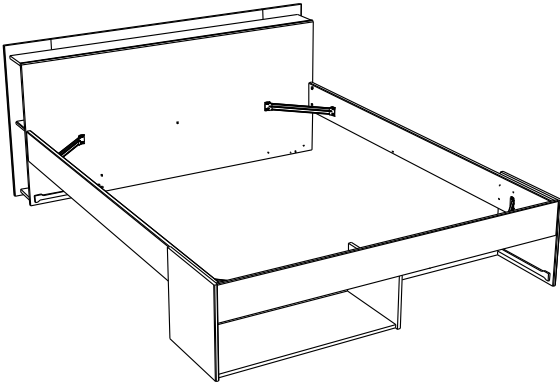
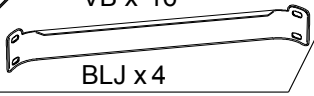

23

BWD x 8

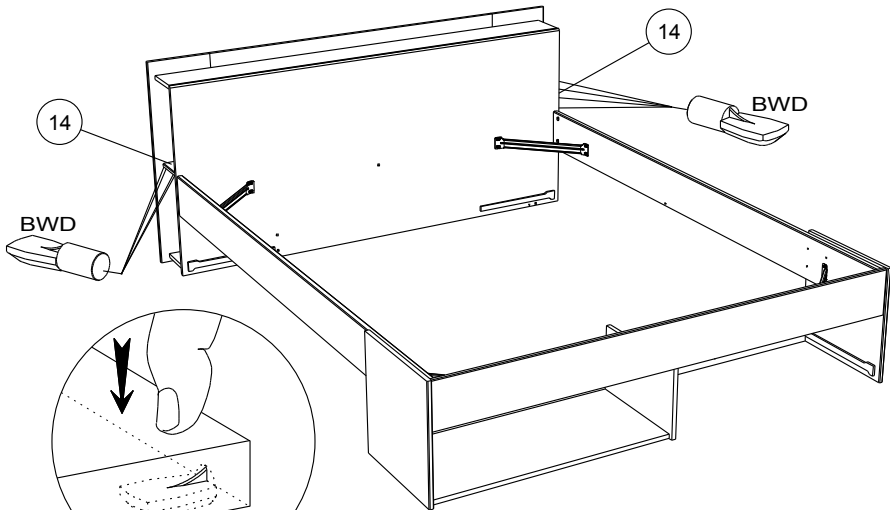

24



ADM x2



VP x 4

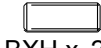

BXH x 2



BSD x 1

25

ADM

ADM

VP x2

AFH

BXH

24

53mm  
2 1/16"

VP x2

AFG

24

BSD

25



BLL x1



VB x 1

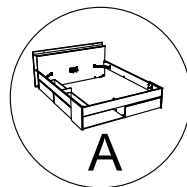

A

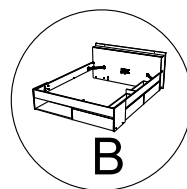
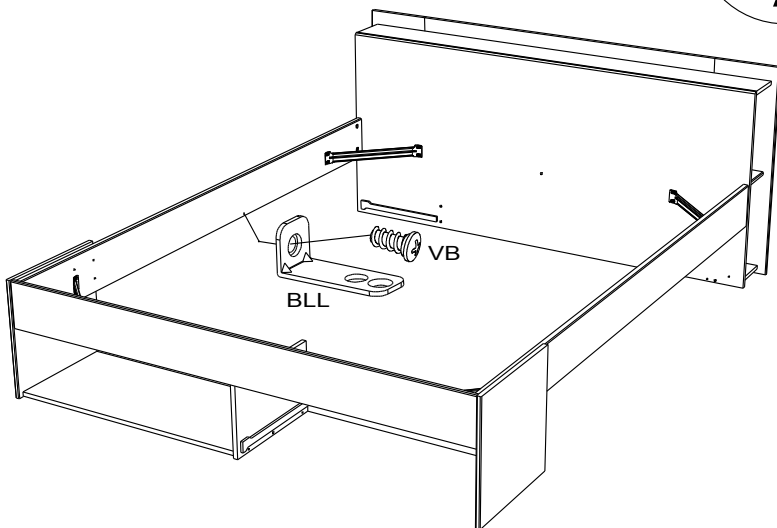

B

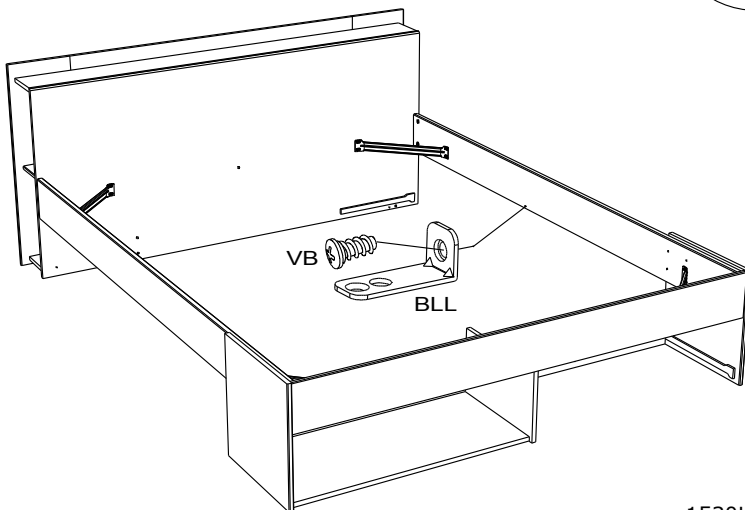

26



Ai x 2

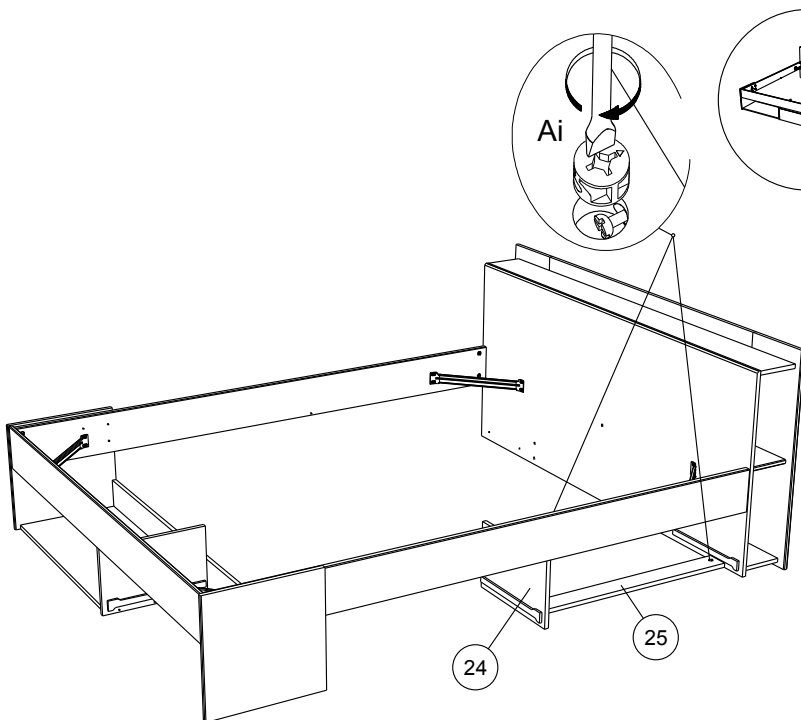
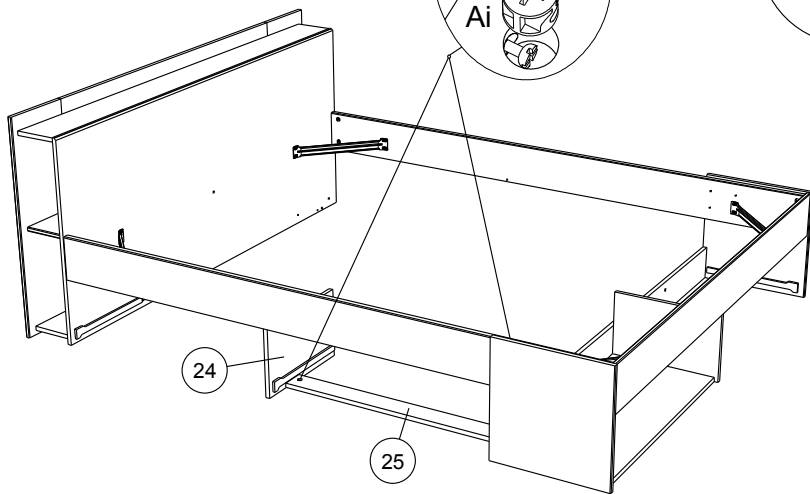

27

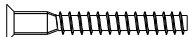

HW x 4

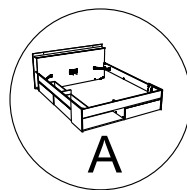

A

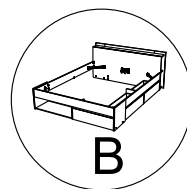
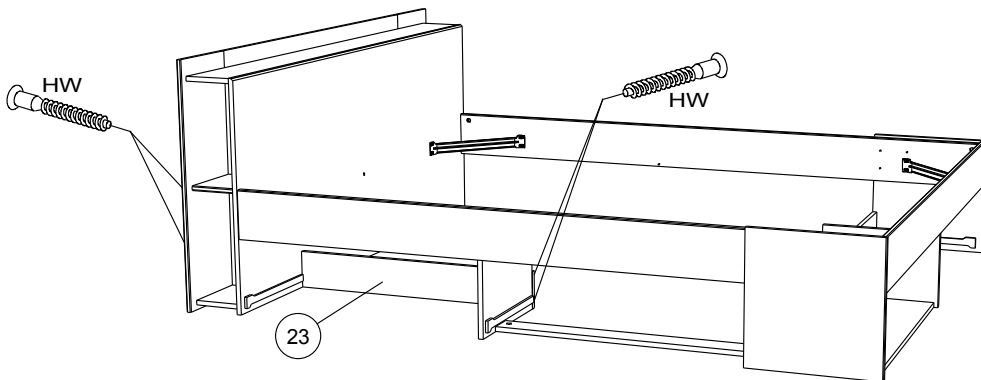

B

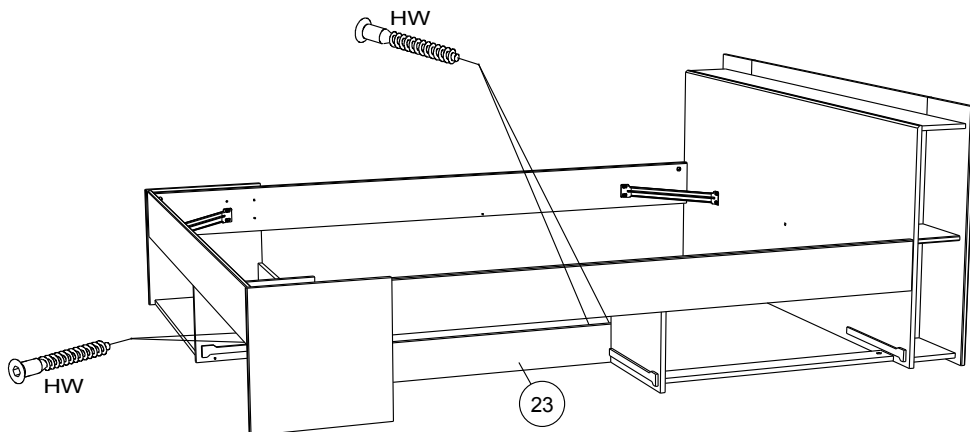

28

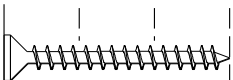
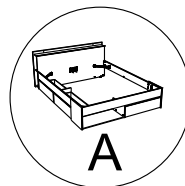
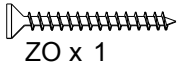

ZO



VJ

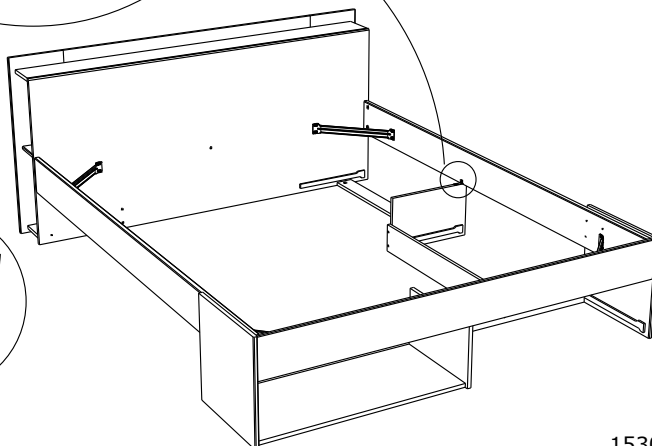
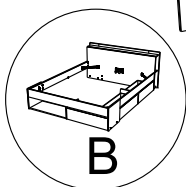
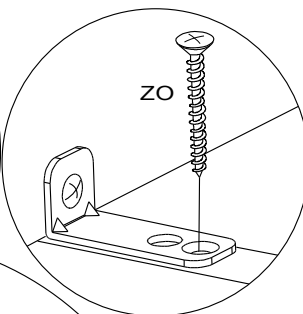
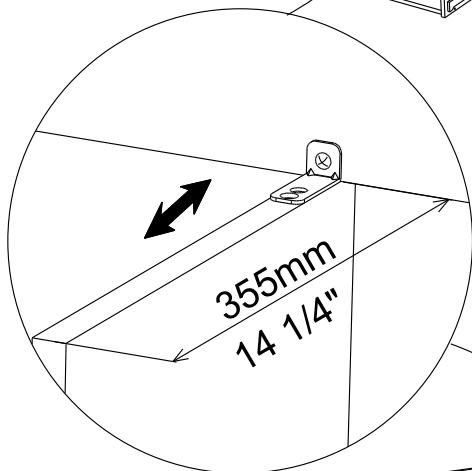
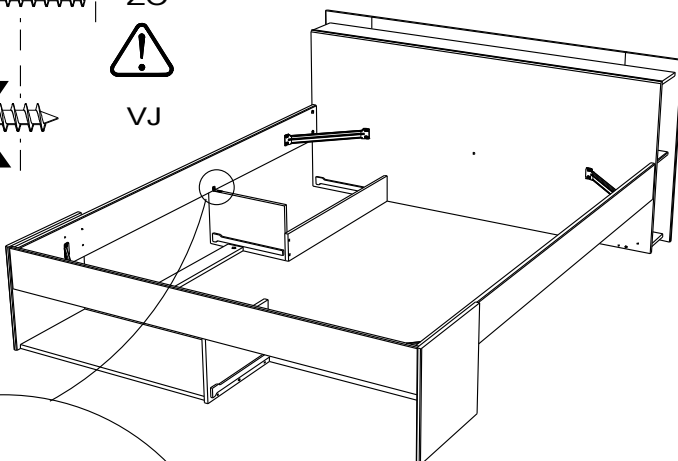
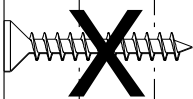



29



EP x 6



VJ x 6

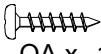

QA x 12

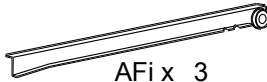

AFi x 3



AFJ x 3

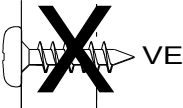

VE

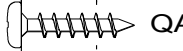

QA

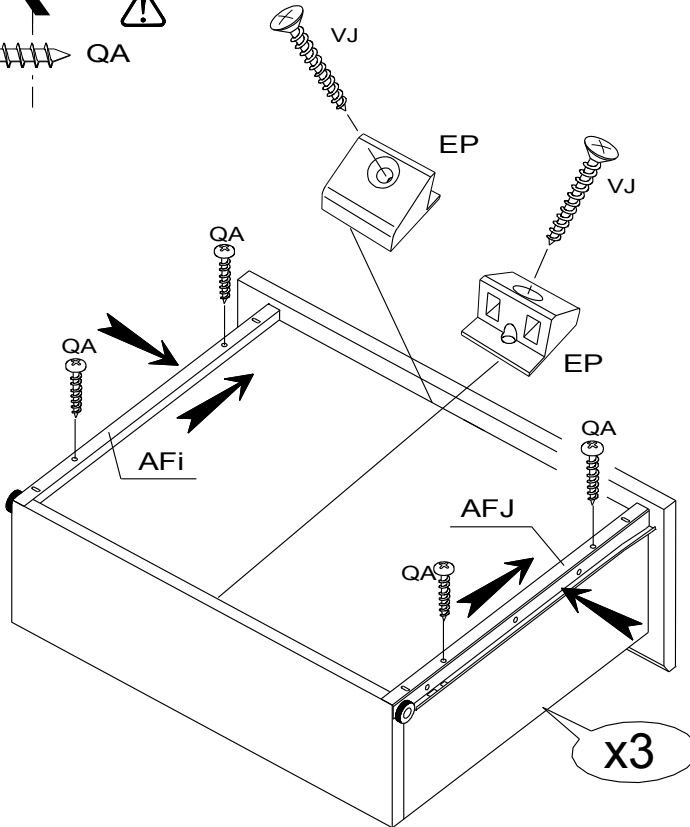

30

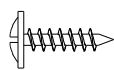

AMO x 15

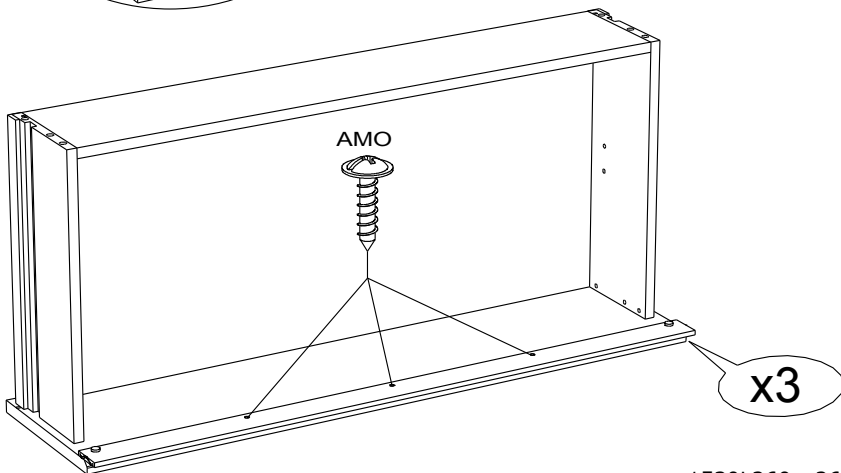
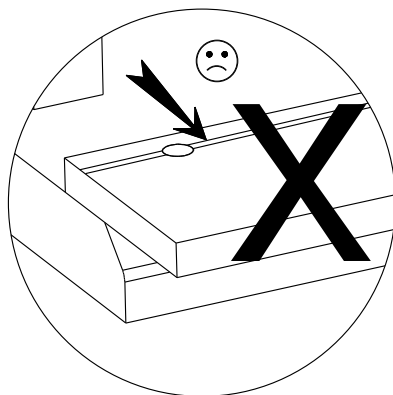
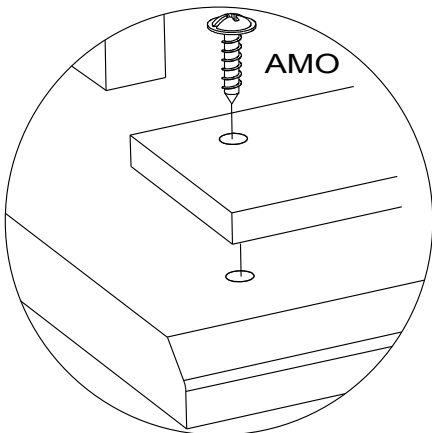
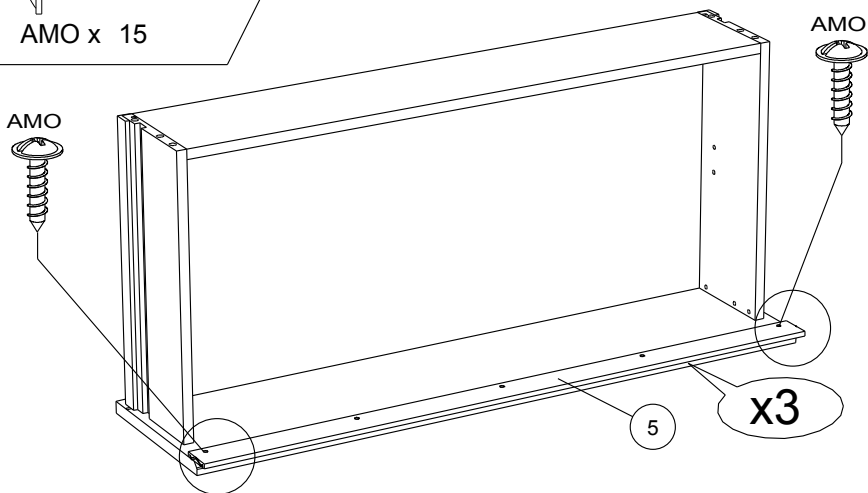

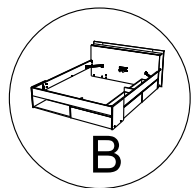
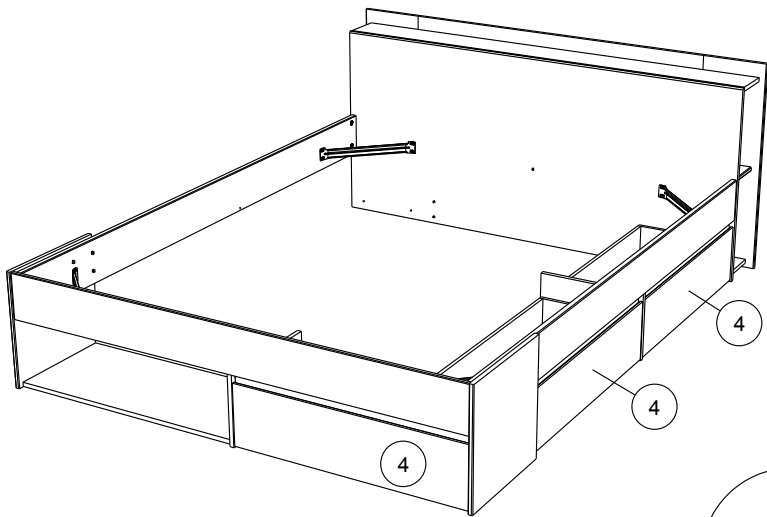
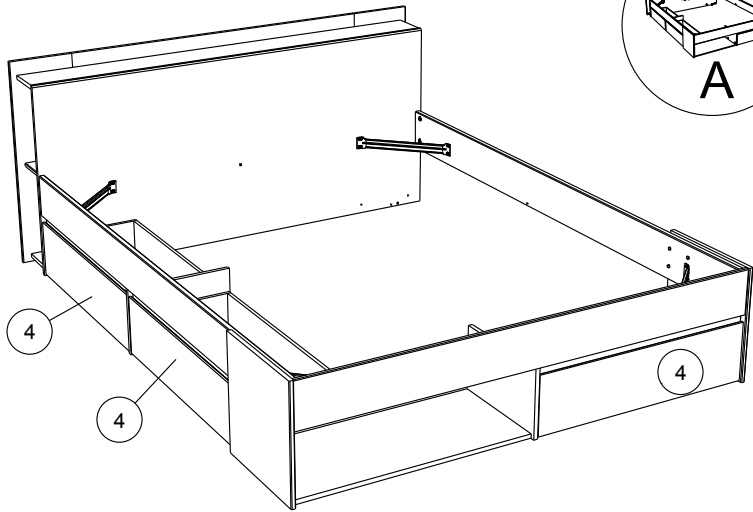

32

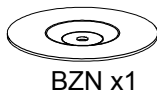
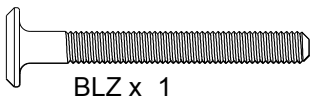
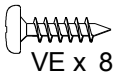

1

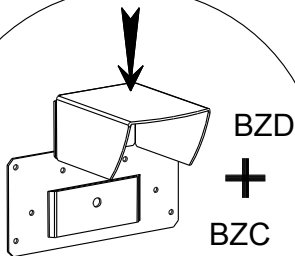

2

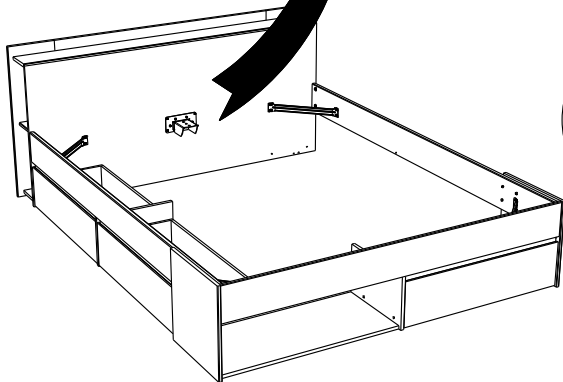
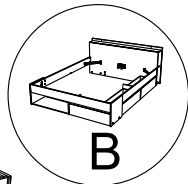
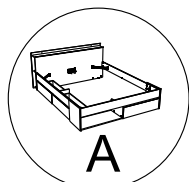
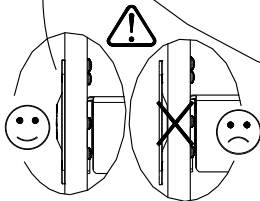
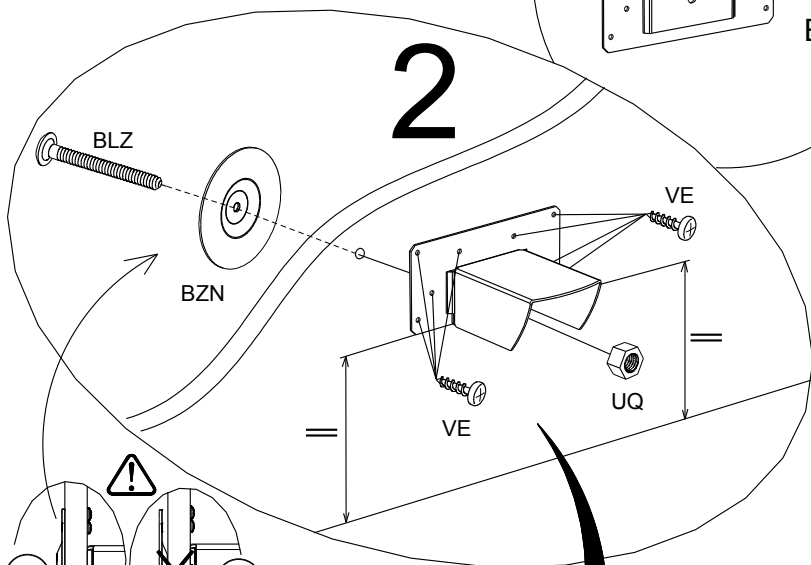

33

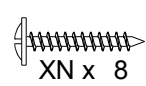
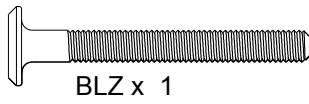
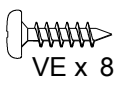

1

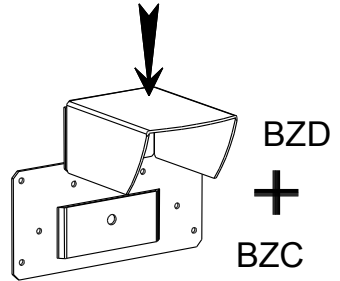

2

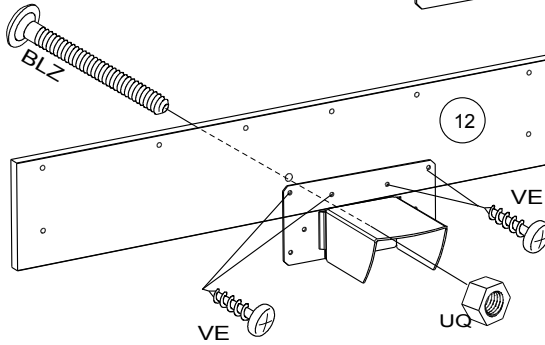

3

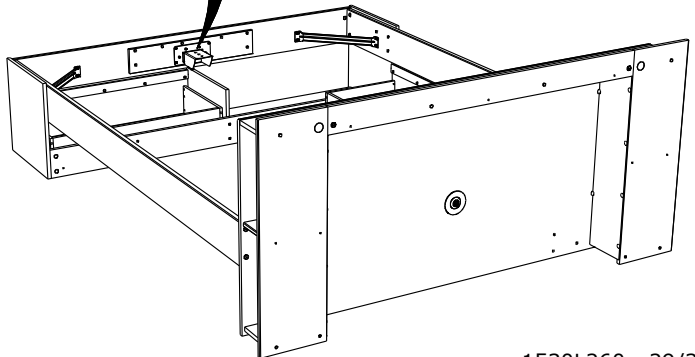
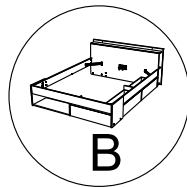
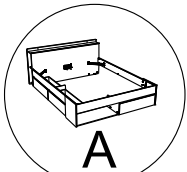
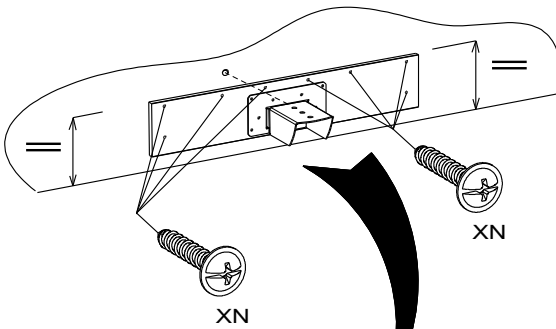

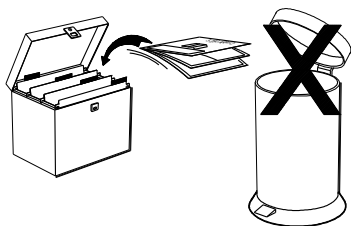

Faites un geste pour l'environnement en triant vos déchets d'emballage  
Make a gesture for the environment by sorting out your waste of packaging  
Machen Sie eine Bewegung für die Umwelt, ihre Verpackungsabfälle sortierend  
Haga un gesto para el medio ambiente escogiendo sus residuos de embalaje



180cm  
70 3/4"

112.5cm  
44 1/4"

52cm  
20 1/2"

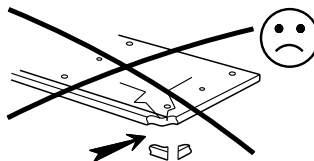
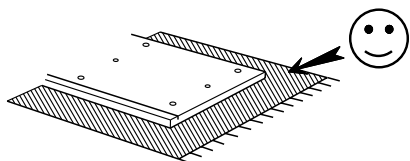
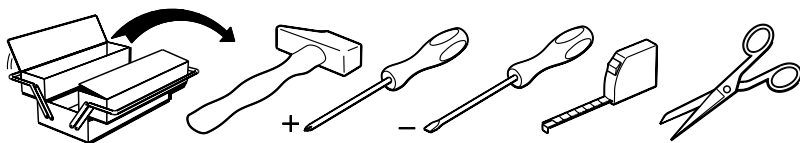
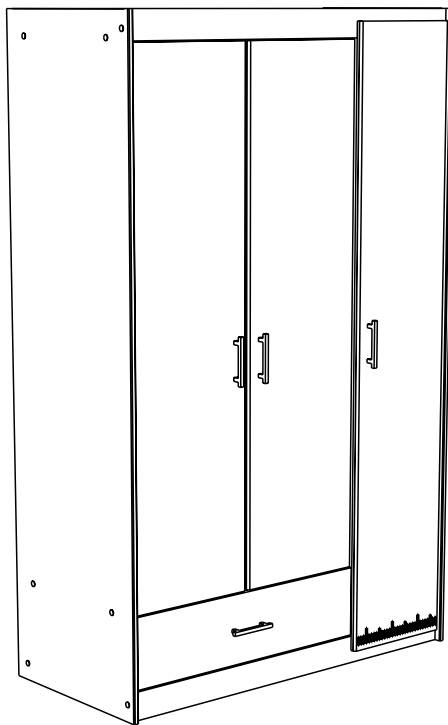

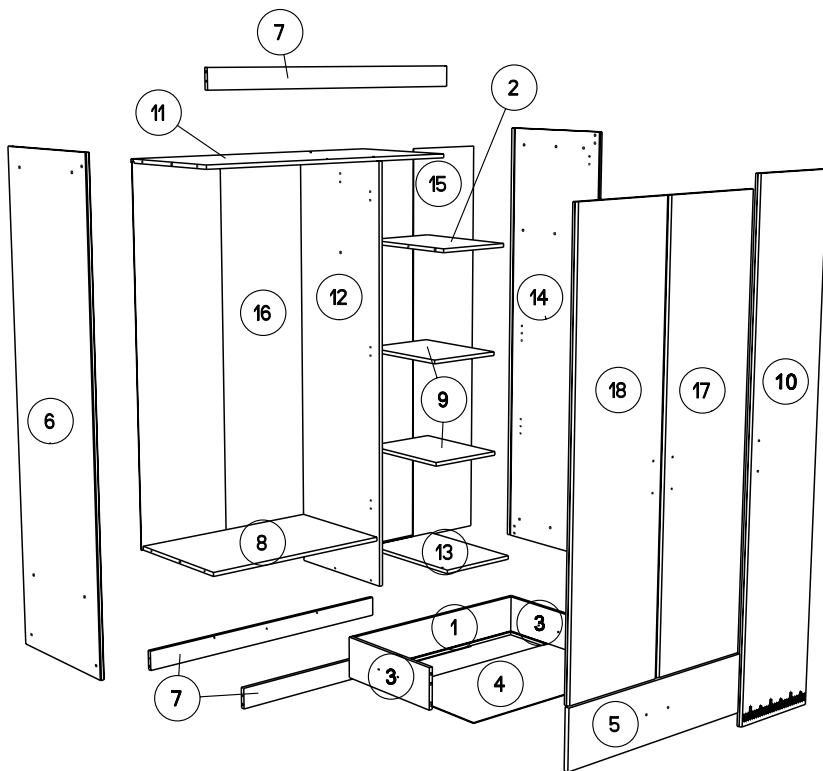

		mm			inch		
9	x 2	415	318	15	16 5/16	12 1/2	9/16
2	x 1	458	318	15	18 1/16	12 1/2	9/16
13	x 1	500	333	15	19 11/16	13 1/8	9/16
5	x 1	755	193	15	29 11/16	7 5/8	9/16
8	x 1	759	465	15	29 7/8	18 5/16	9/16
7	x 3	1092	77	15	43	3	9/16
11	x 1	1092	485	15	43	19 1/8	9/16
17	x 1	1440	376	15	56 11/16	14 13/16	9/16
18	x 1	1440	376	15	56 11/16	14 13/16	9/16
12	x 1	1629	480	15	64 1/8	18 7/8	9/16
10	x 1	1729	331	15	68 1/16	13 1/16	9/16
6	x 1	1797	520	15	70 3/4	20 1/2	9/16
14	x 1	1797	520	15	70 3/4	20 1/2	9/16
3	x 2	400	139	13	15 3/4	5 1/2	1/2
1	x 1	708	139	13	27 7/8	5 1/2	1/2
4	x 1	718	399	3	28 1/4	15 11/16	1/8
16	x 1	1460	775	3	57 1/2	30 1/2	1/8
15	x 1	1645	333	3	64 3/4	13 1/8	1/8

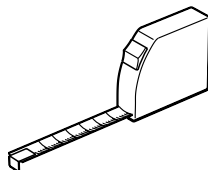



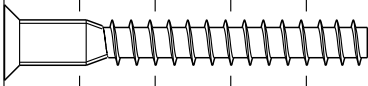
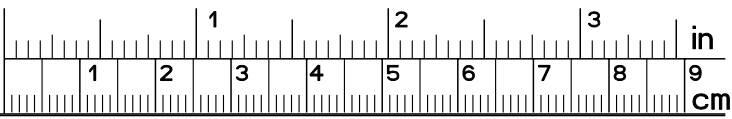

HW x 22



HV x 1



ADM x 21

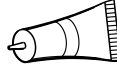

CF x 1



ADU x 6



DC x 1

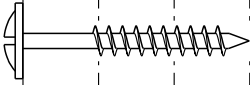

WH x 8

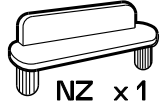

NZ x 1

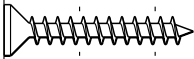

VJ x 11



FA x 4



WA x 15

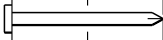

YB x 4

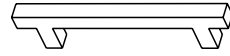

X4



EP x 6

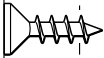

VG x 5

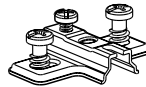

BWU x 9

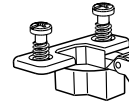

BWY x 9

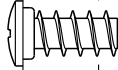

VB x 6

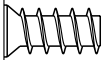

BWF x 4



GZ x 2

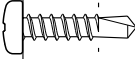

BRL x 4

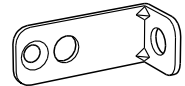

BLL x 4

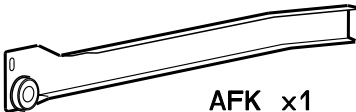

AFK x 1

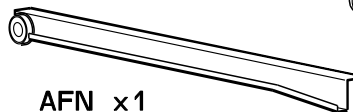

AFN x 1

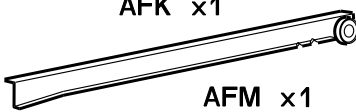

AFM x 1

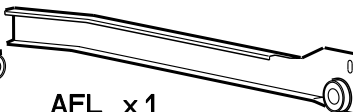

AFL x 1



BWD x 8

**1**

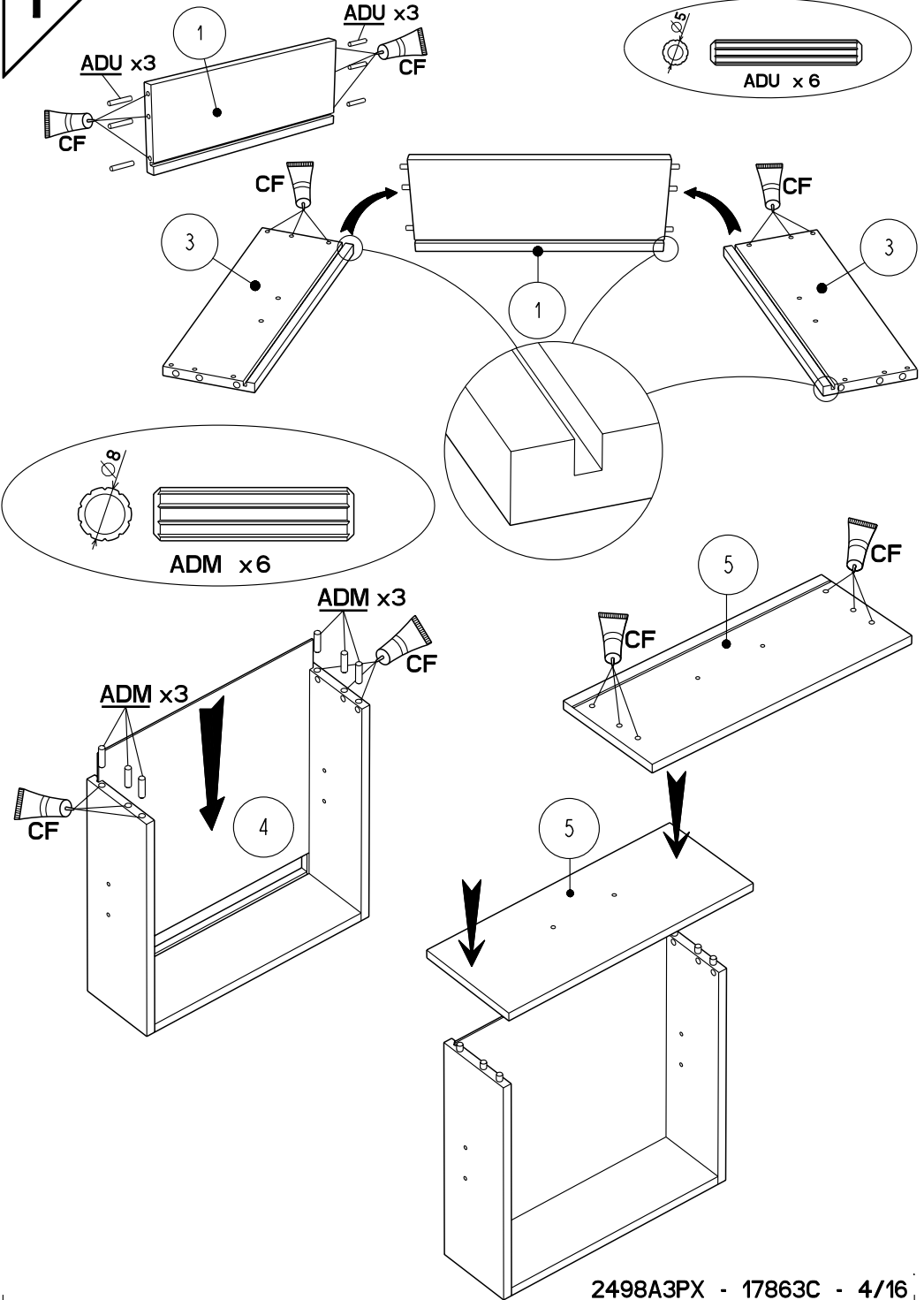

**2**

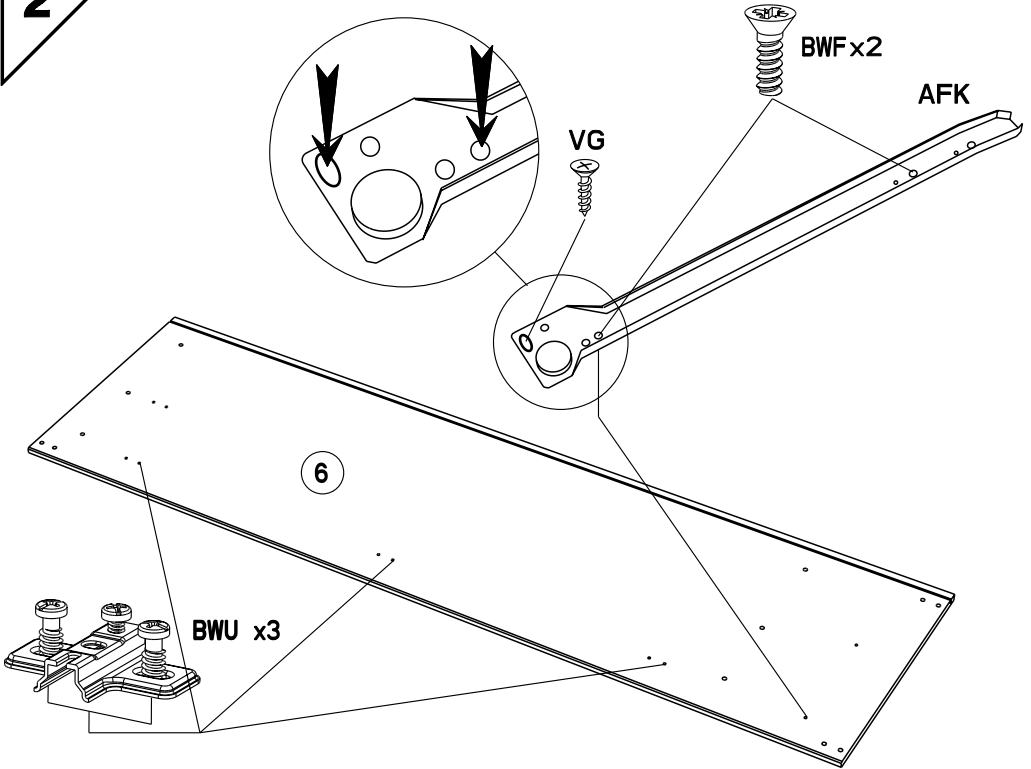

**3**

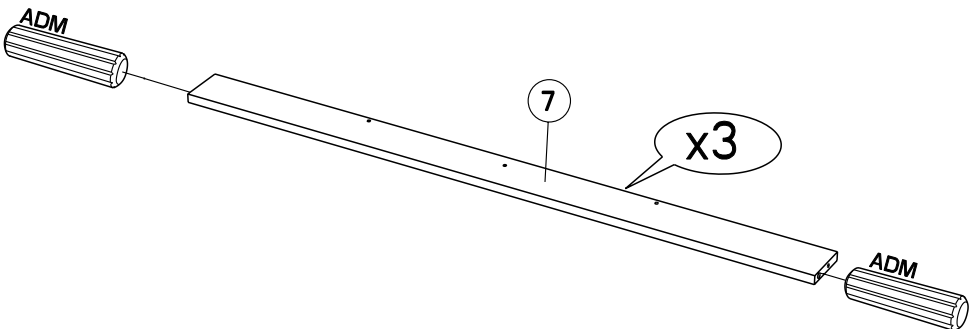

**4**

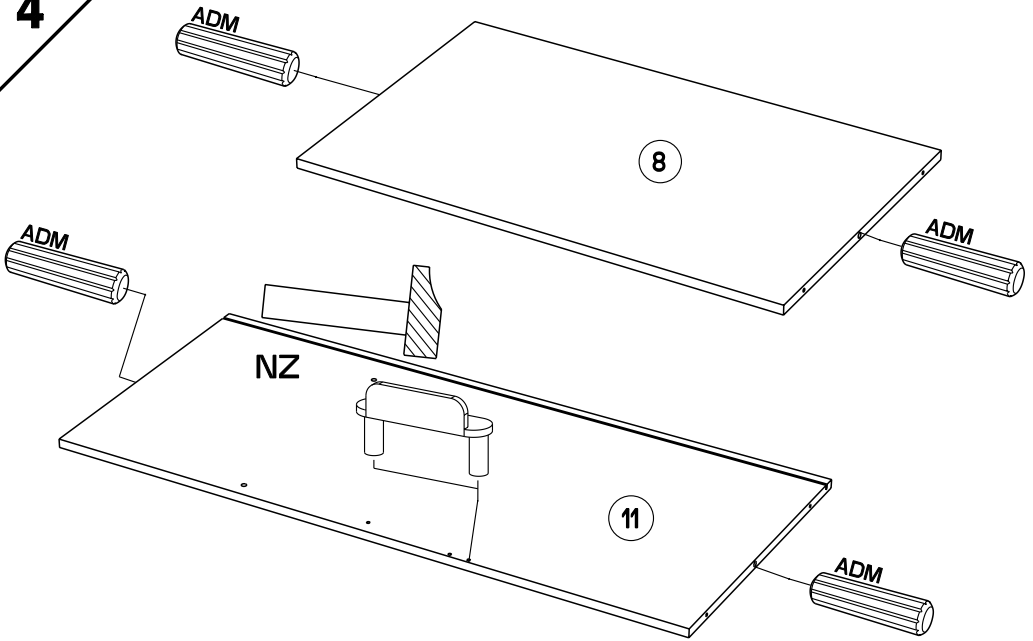

**5**

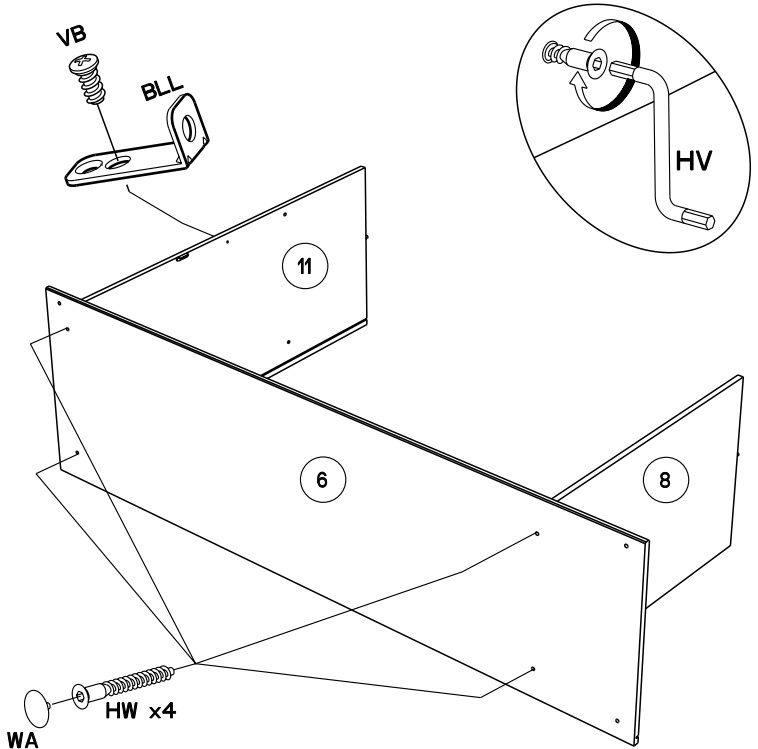

**6**

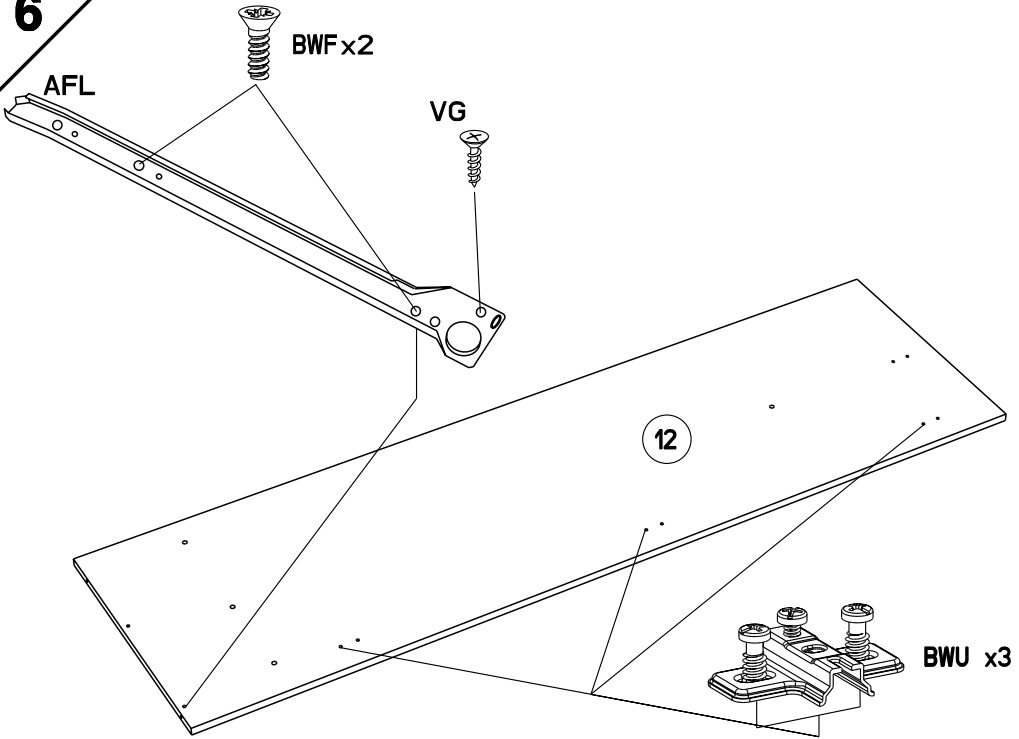

**7**

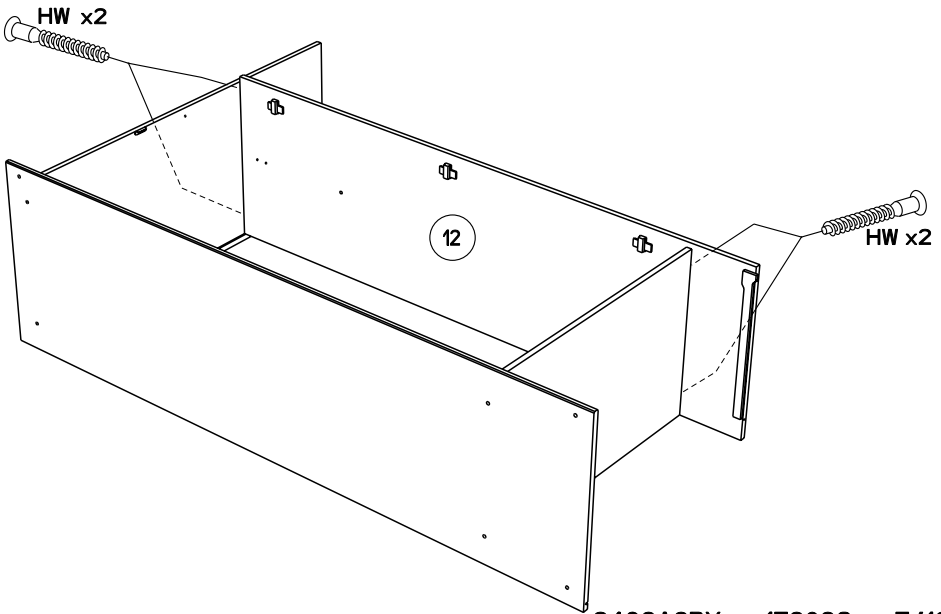

**8**

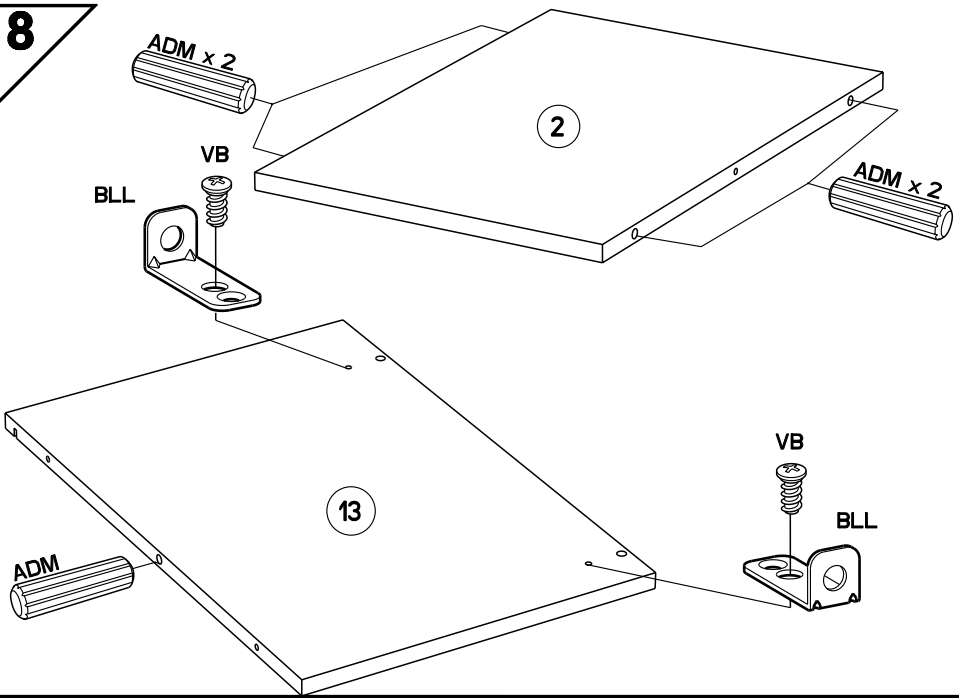

**9**

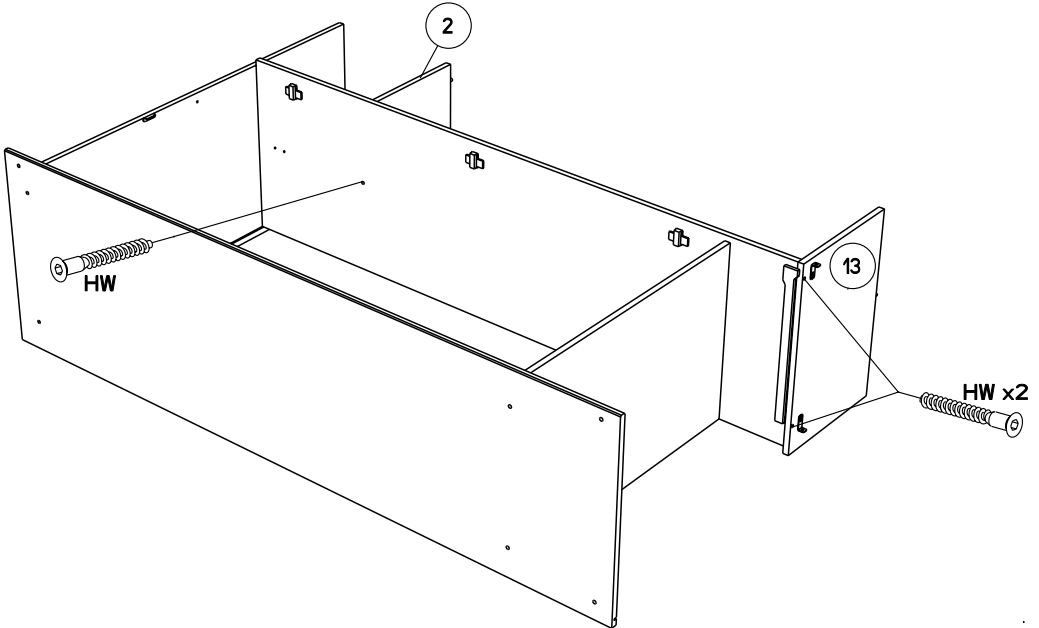

**10**

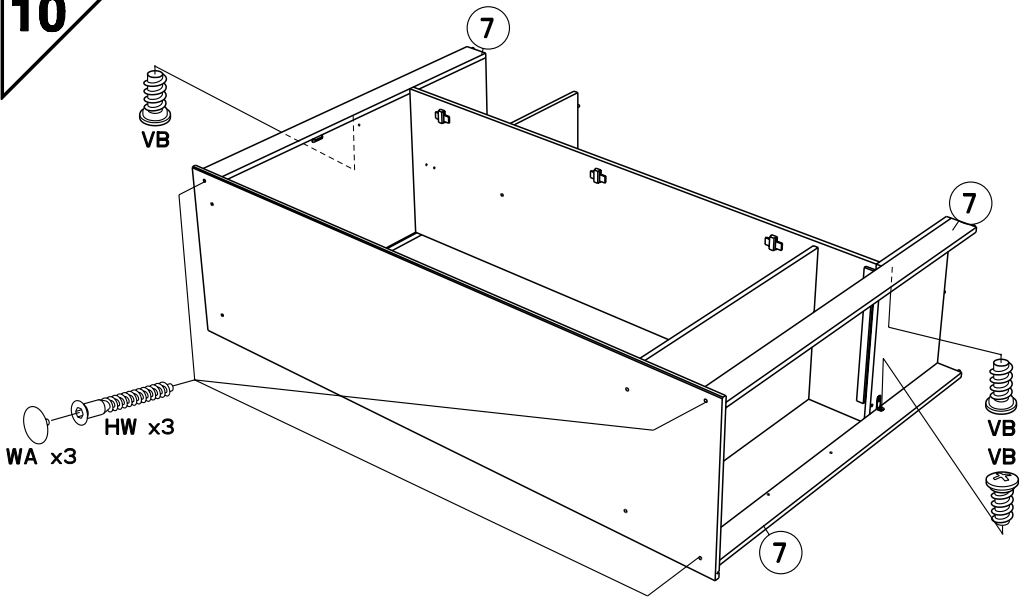

**11**

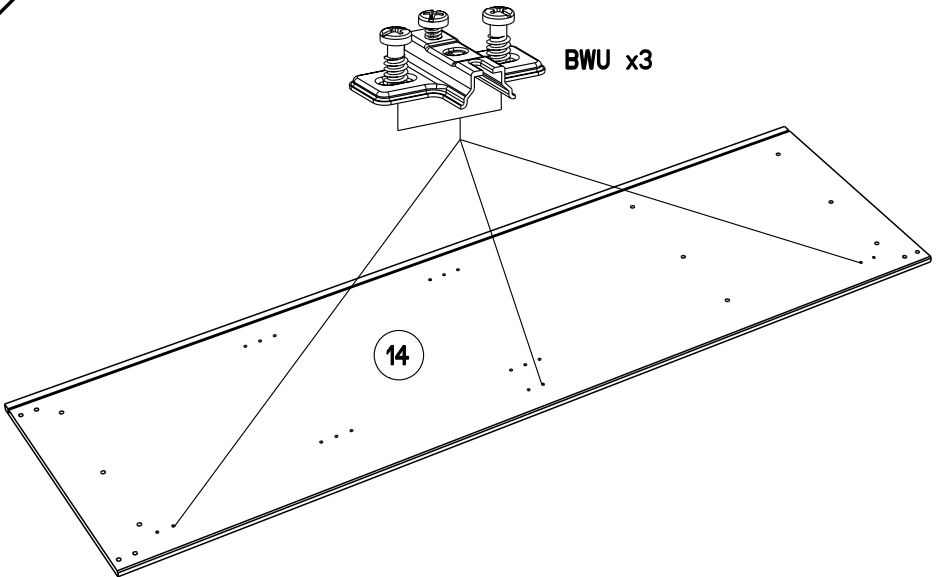

12

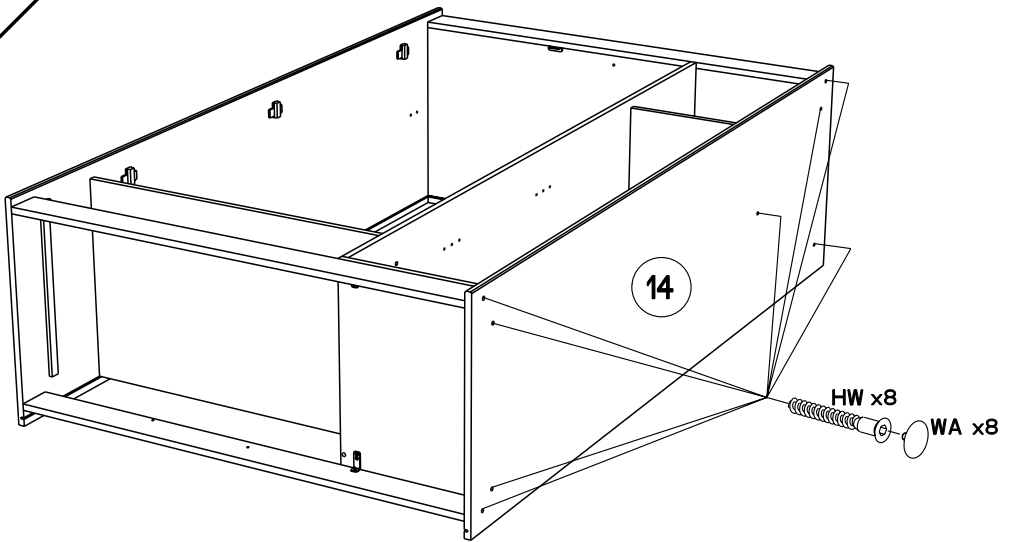

13

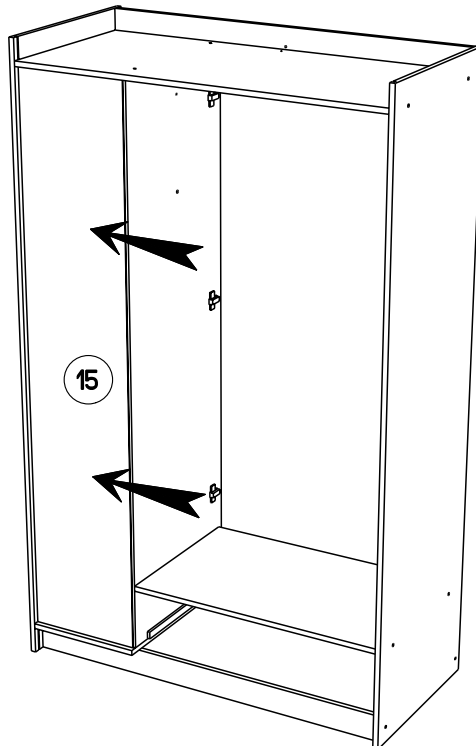



14

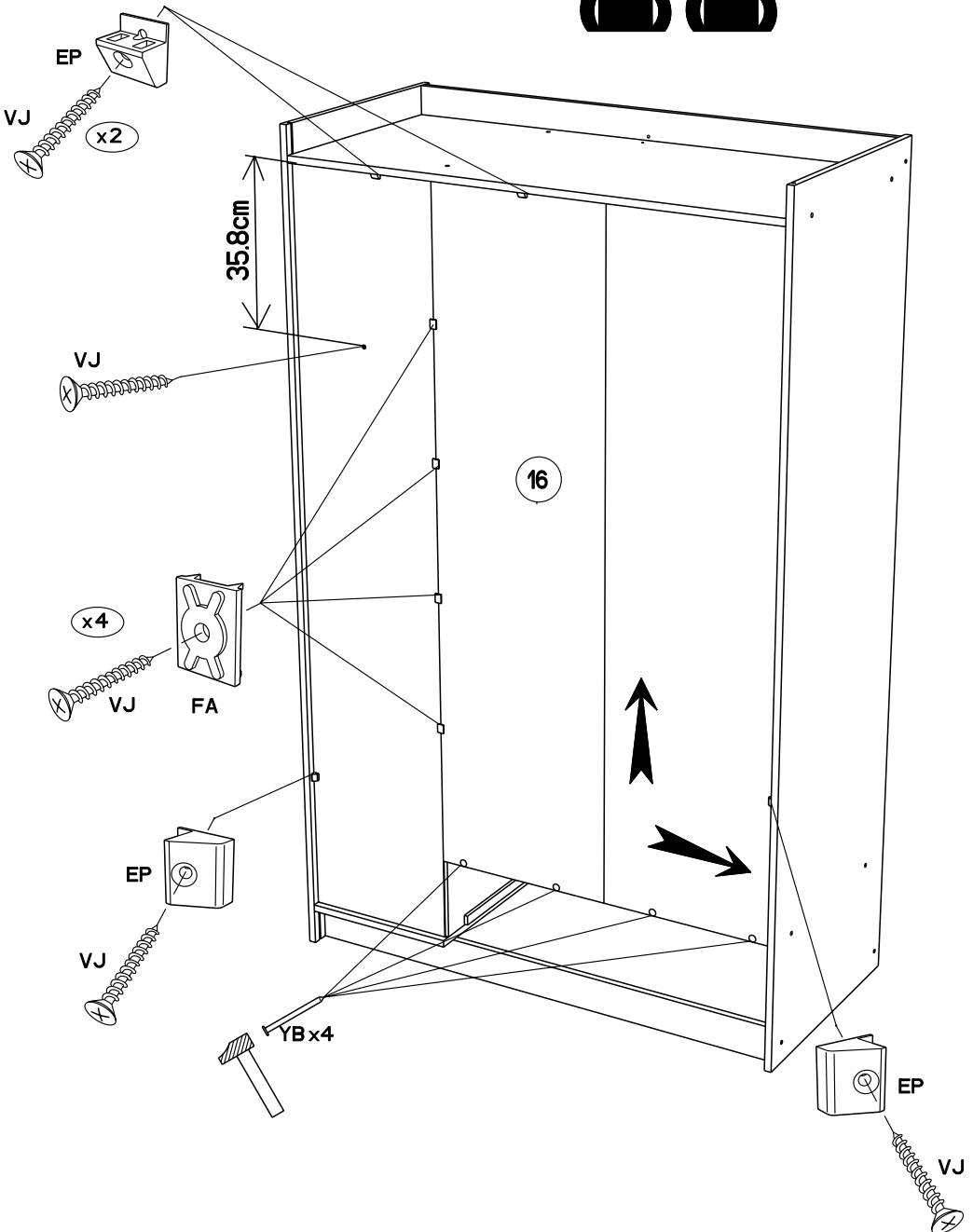
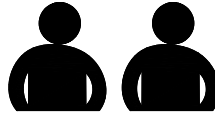

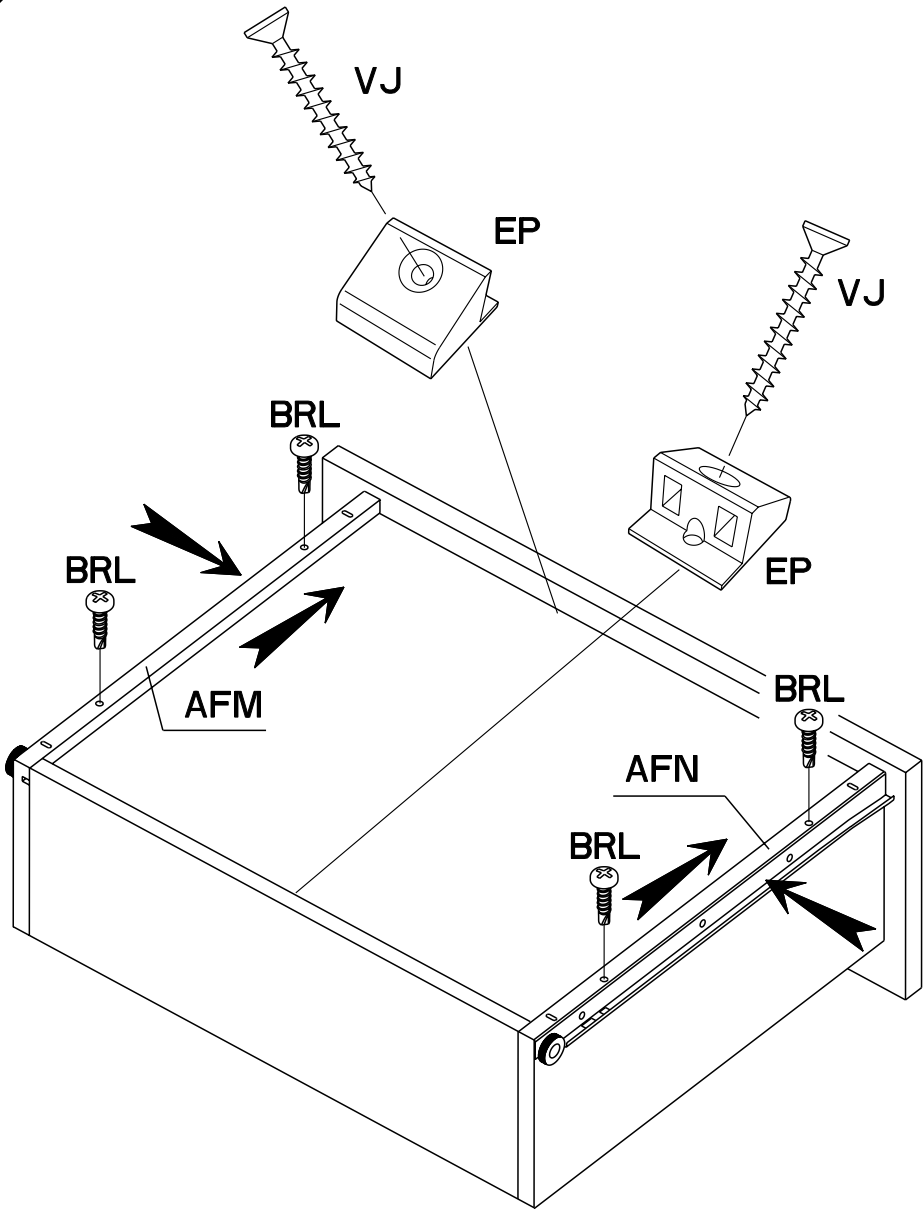

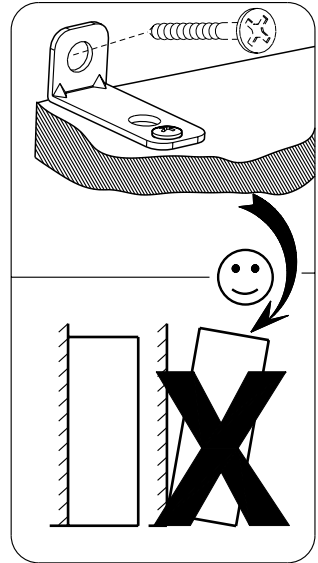
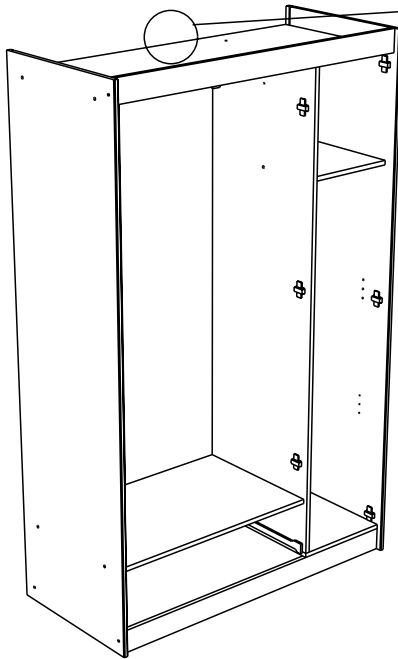

**FR** Pour votre sécurité : Fixation du meuble au mur  
Attention, la fixation doit être réalisée par une personne compétente car cela nécessite des chevilles adaptées à la nature de votre mur.

**GB** For your own safety: attach the furniture to the wall  
Important! The furniture must be attached by a qualified person using dowels that are suited to the type of wall.

**D** Für Ihre Sicherheit: Befestigung des Möbelstücks an der Wand  
Achtung, die Befestigung muss von einem Fachmann vorgenommen werden, weil sie an die Wand angepasste Dübel erfordert.

**E** Para su seguridad: Fijación del mueble a la pared  
¡Ojo! La fijación deberá llevarla a cabo una persona competente ya que necesitará unos tacos adaptados a tipo de pared.

**PT** Para a sua segurança: Fixação do móvel na parede  
Atenção, a fixação deve ser efectuada por uma pessoa competente, pois exige a utilização de cavilhas adaptadas à natureza da parede.

**I** Per la vostra sicurezza: fissaggio del mobile alla parete.  
Nota bene, il fissaggio deve essere eseguito da personale specializzato, poiché l'utilizzo di tasselli adattati alla parete.

**NL** Voor uw veiligheid: bevestiging van het meubel aan de muur.  
Let op, de bevestiging moet worden uitgevoerd door een bevoegd persoon, want hiervoor zijn pluggen nodig die specifiek geschikt zijn voor de betreffende muur.

17

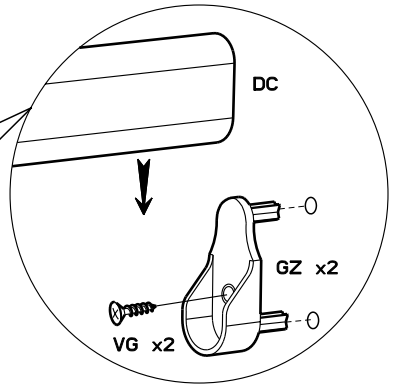
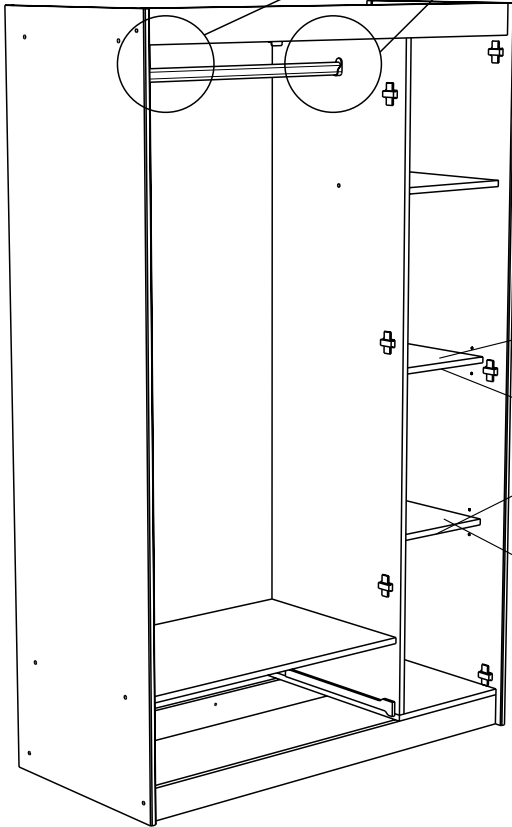

9

BWD x 8

9

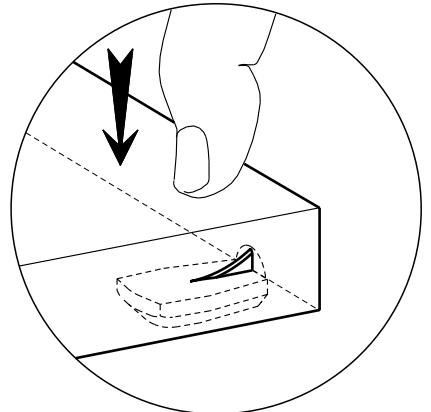

**18**

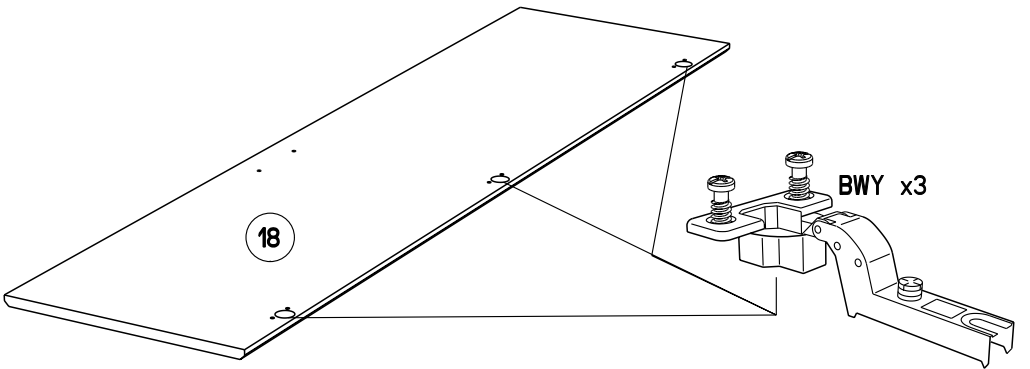
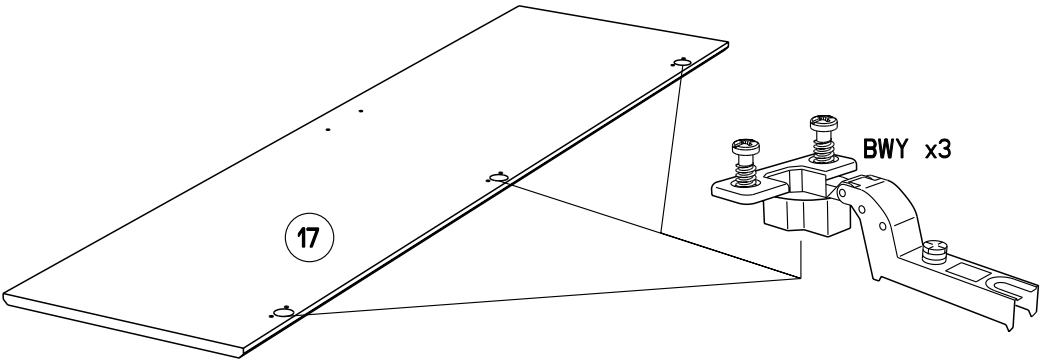
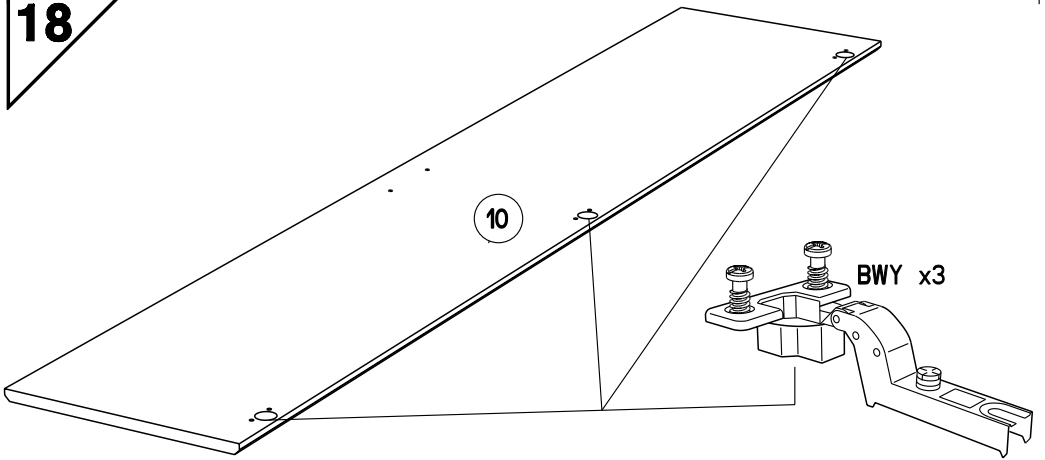

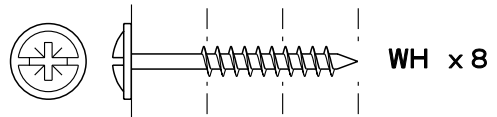
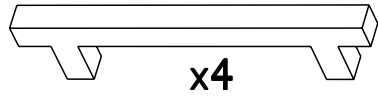
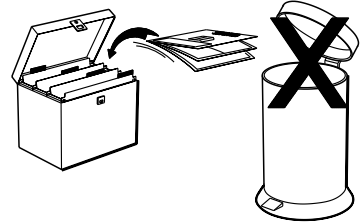

RCH-N

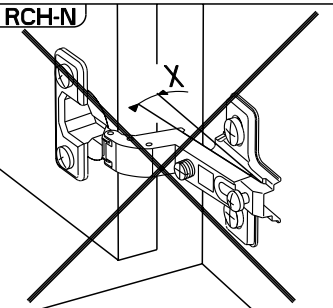

**MONTAGE**

- ⓄB LEAFLET AUFBAUANLEITUNG
- ⓄD MONTAJE MONTAGEM
- ⓄE MONTAJE MONTAGEM
- ⓄP REGULACAO
- ⓄI MONTAGGIO
- ⓄNL MONTAGE

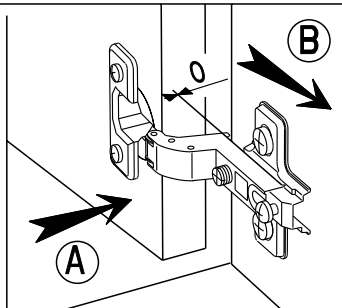

**REGLAGE** ⓄB ADJUSTING ⓄE A-JUSTER ⓄI AGGIUSTAMENTO  
 ⓄD ANPASSUNG ⓄP REGULACAO ⓄNL AFSTELLING

A

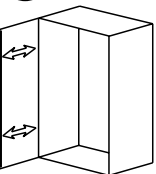

B

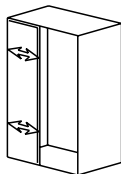

C

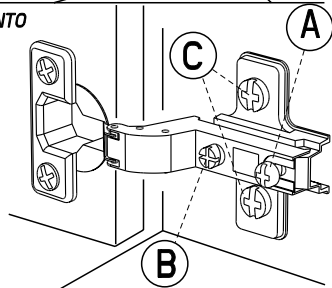
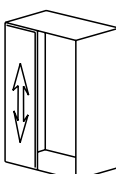

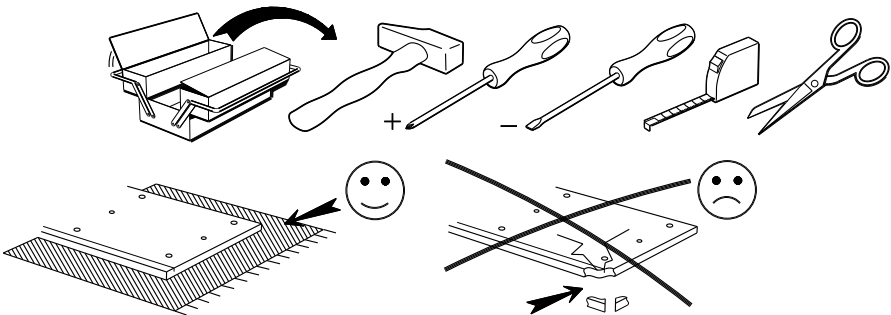
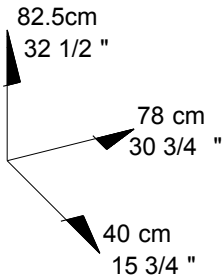
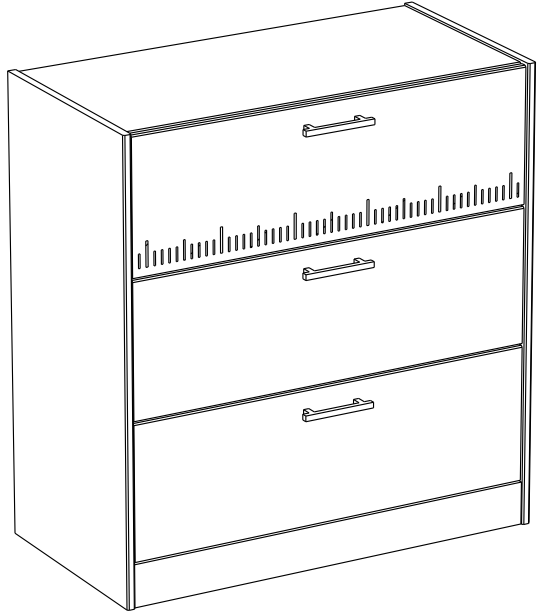
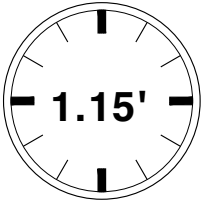

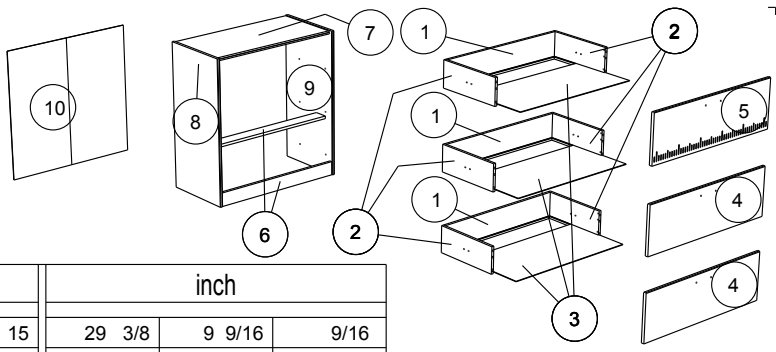

		mm			inch		
4	x 2	746	243	15	29 3/8	9 9/16	9/16
5	x 1	746	243	15	29 3/8	9 9/16	9/16
6	x 2	750	77	15	29 1/2	3	9/16
7	x 1	750	378	15	29 1/2	14 7/8	9/16
9	x 1	821	398	15	32 5/16	15 11/16	9/16
8	x 1	821	398	15	32 5/16	15 11/16	9/16
2	x 6	350	139	13	13 3/4	5 1/2	1/2
1	x 3	699	139	13	27 1/2	5 1/2	1/2
3	x 3	709	349	3	27 15/16	13 3/4	1/8
10	x 1	774	756	3	30 1/2	29 3/4	1/8

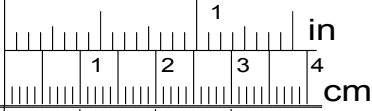
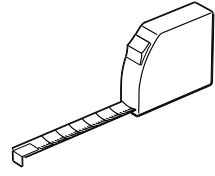

		ADM x 26			VG x 7
		ADU x 18			BWF x 12
		WH x 6			EP x 6
		VJ x 6			BLL x 1
		BSD x 8			Ai x 8
		YB x 16			AFG x 3
		BRL x 12			AFi x 3
					AFJ x 3
					BWD x 2
					AFH x 3
					POI x 3



1

X3

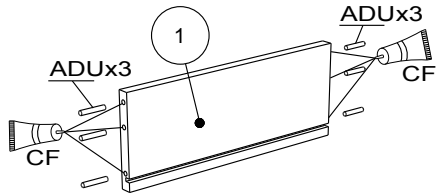

X3

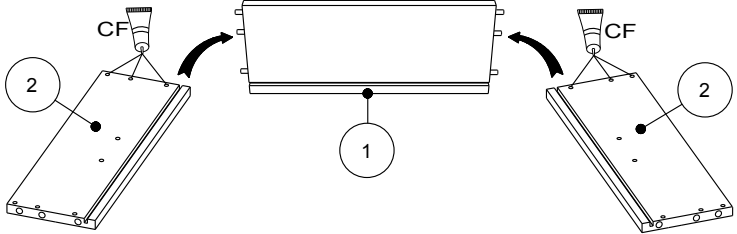

X3

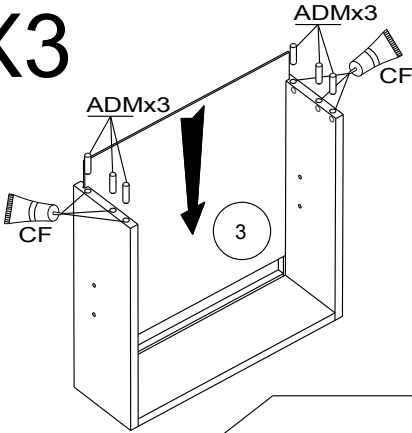

X2

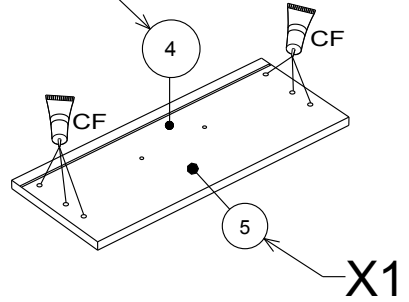

X2

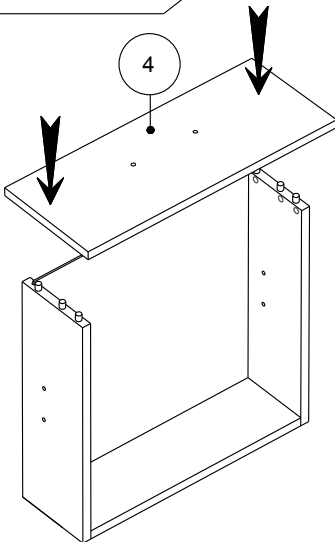

X1

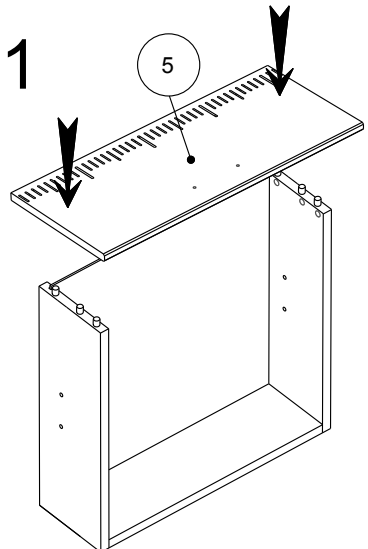

2

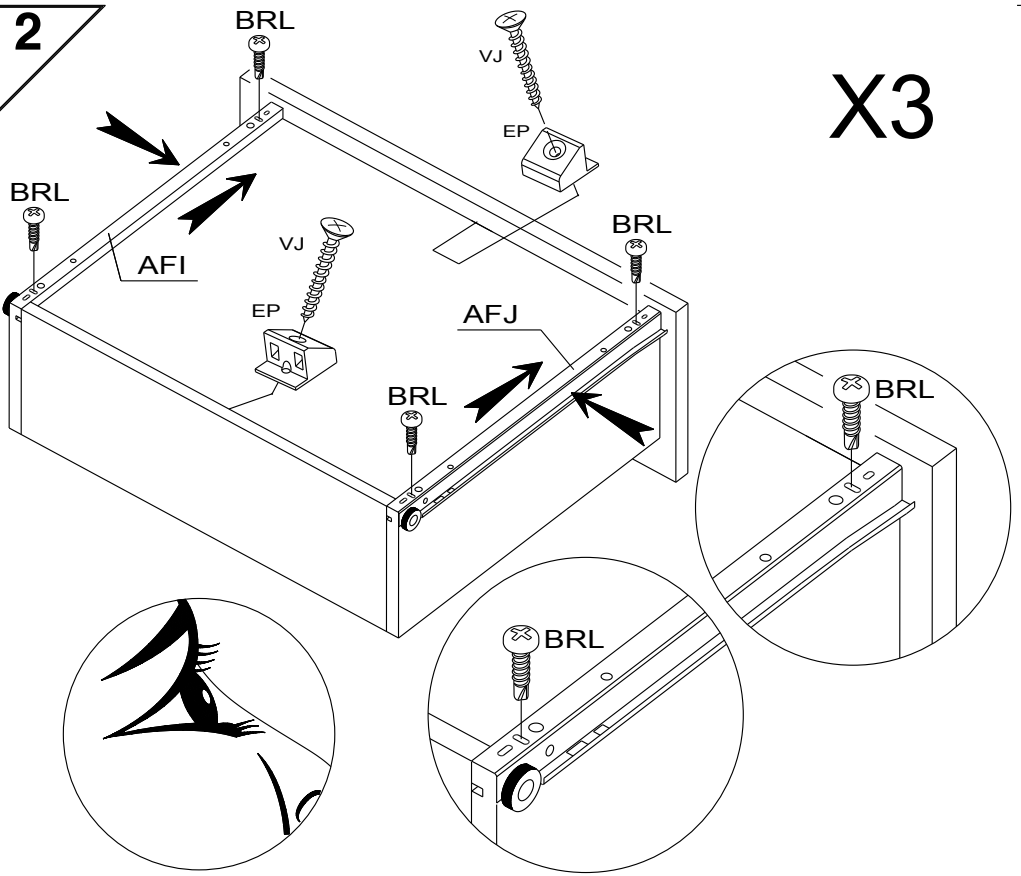

X3

3

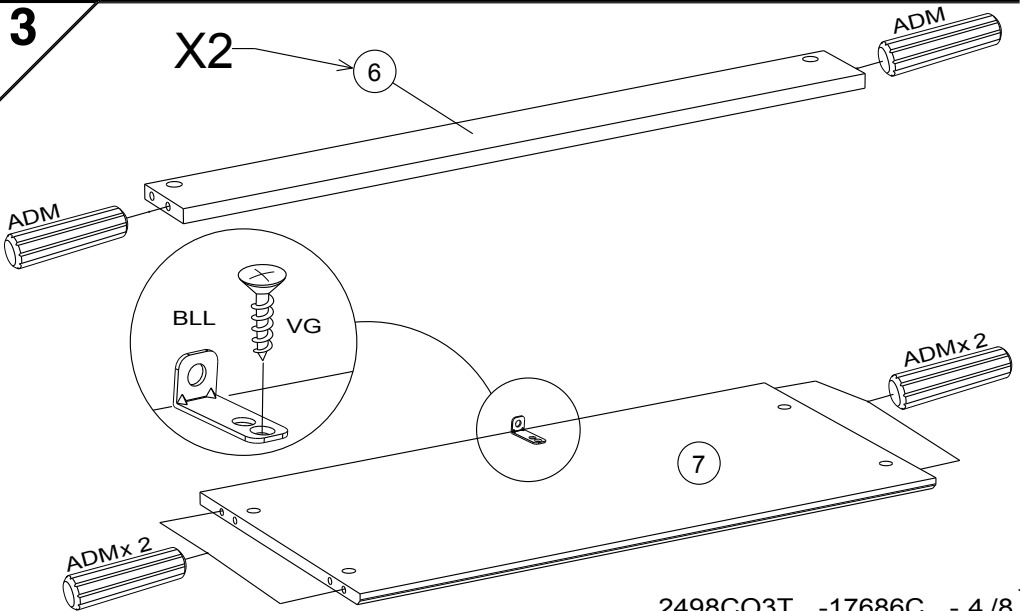

4

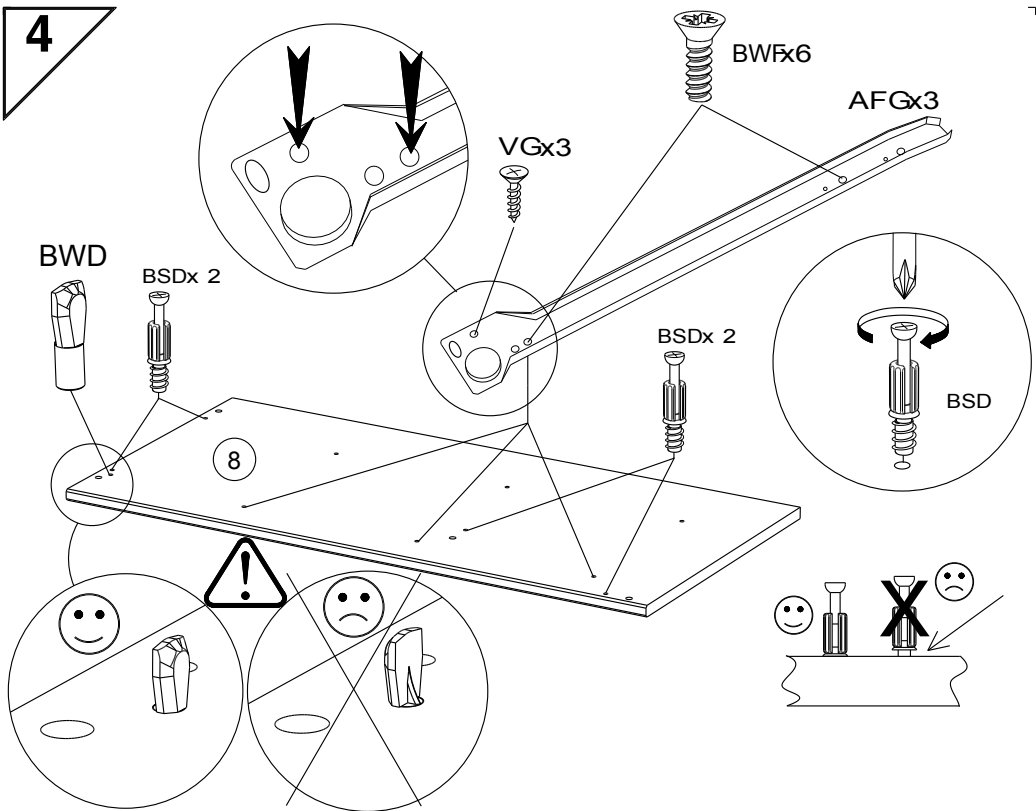

5

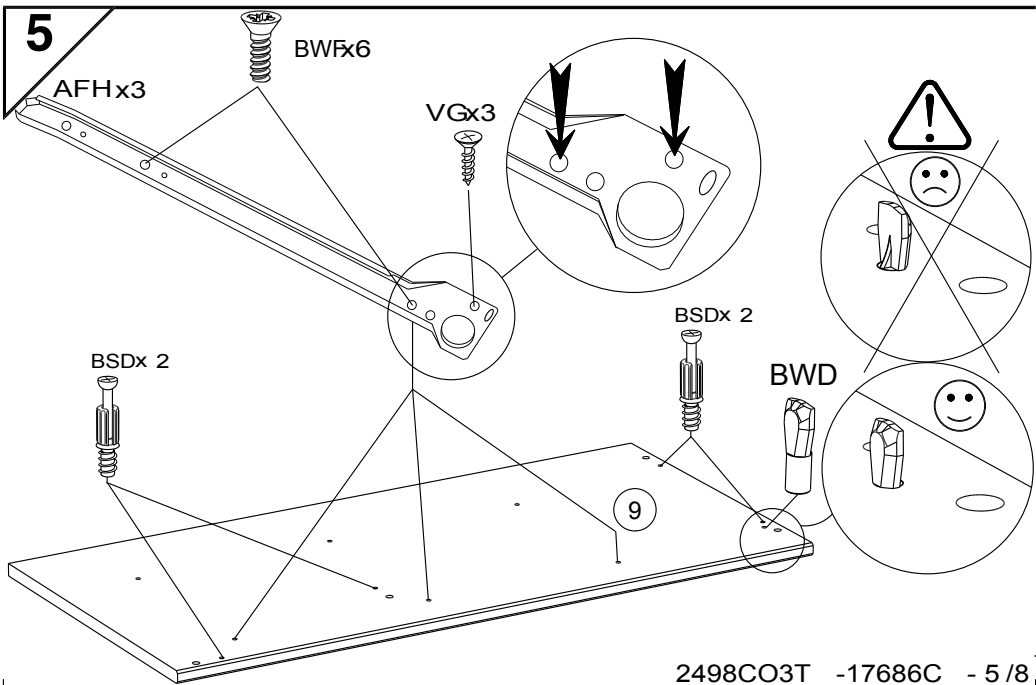

6

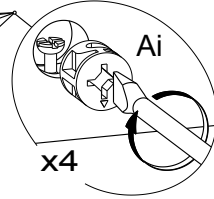
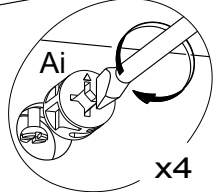
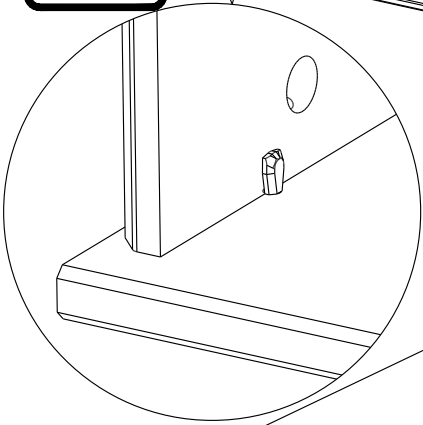
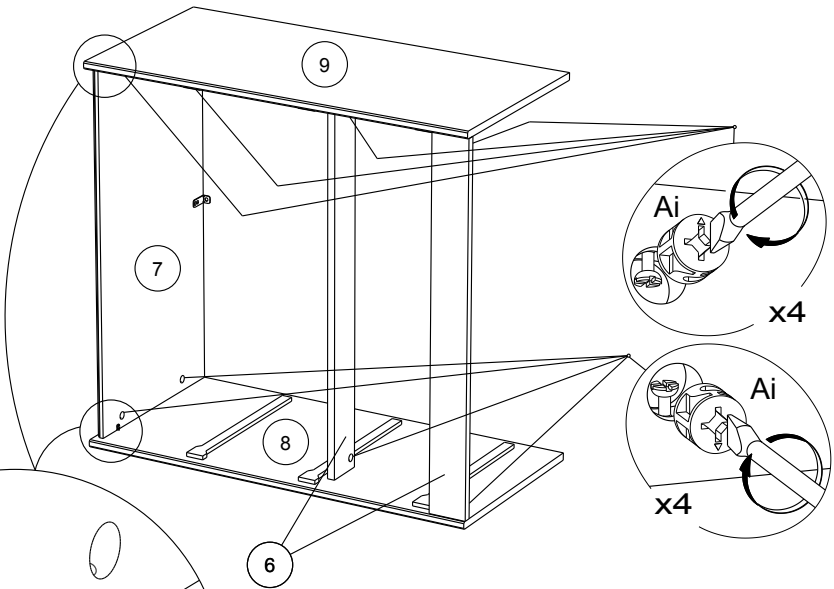

7

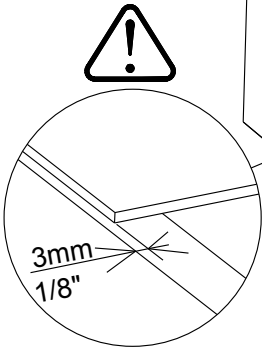
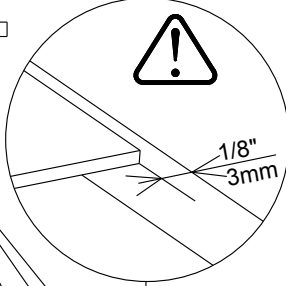
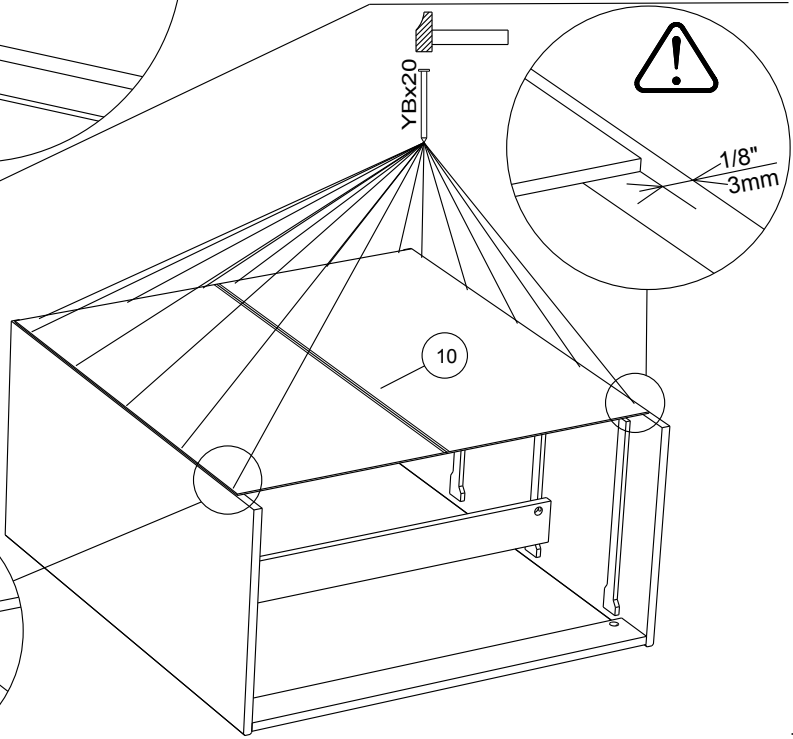

- FR** Pour votre sécurité : Fixation du meuble au mur  
Attention, la fixation doit être réalisée par une personne compétente car cela nécessite des chevilles adaptées à la nature de votre mur.
- EN** For your safety: the unit should be secured to the wall.  
NB this should be carried out by a competent person as you must use the right rawlplug for your type of wall.
- DE** Zu Ihrer Sicherheit: Befestigen Sie das Hochbett an der Wand.  
Achtung: Diese Befestigung ist durch eine fachlich kompetente Person vorzunehmen. Hierfür sind für die Bauweise Ihrer Wand geeignete Dübel einzusetzen.
- ES** Por su seguridad: Fijar el mueble a la pared.  
Advertencia: la fijación la ha de llevar a cabo por personal adecuado, ya que requiere el uso de tacos que se adapten al tipo de pared.
- PT** Para sua segurança: fixação do móvel ao muro  
Atenção: a fixação deverá ser efetuada por pessoa habilitada, visto que são necessárias cavilhas adaptadas ao tipo de parede.
- IT** Avvertenza di sicurezza: il fissaggio del mobile a parete deve essere realizzato da una persona competente, in quanto l'operazione richiede l'impiego di tasselli adatti alla natura del muro.
- NL** Voor uw veiligheid: bevestiging van het meubel aan de muur.  
Opgelet de bevestiging moet worden uitgevoerd door een bekwaam persoon daar dit voor uw type muur geschikte pluggen vereist.
- CZ** Z bezpečnostních důvodů: upevněte nábytek do zdi  
Pozor, upevnění je třeba svěřit kompetentní osobě, neboť vyžaduje hmoždinky vhodné pro vaši zeď.
- HU** Az Ön biztonsága érdekében : a bútor falra rögzítése  
Figyelmeztetés : a rögzítés csak megfelelő szakképesítéssel rendelkező személy által végezhető el, mert a rögzítéshez a falnak megfelelő csavarokra van szükség.
- PL** Dla bezpieczeństwa: mocowanie mebla do ściany  
Uwaga, mocowanie musi zostać wykonane przez osobę kompetentną, ponieważ wymaga to zastosowania kołków dostosowanych do rodzaju ściany.
- RO** Pentru securitatea dumneavoastră: fixarea mobilierului de perete  
Atenție, fixarea trebuie să fie realizată de o persoană calificată, deoarece sunt necesare dispozitive de fixare adaptate caracteristicilor peretelui dumneavoastră
- RU** Для вашей безопасности: Крепление мебели к стене  
Внимание! Крепление должно производиться опытным специалистом, т.к. для такой установки потребуются штифты, соответствующие типу вашей стены.
- SK** Z bezpečnostných dôvodov: nábytok upevnite k stene.  
Dbajte na to, aby upevnenie vykonala kompetentná osoba, pretože pri upevňovaní sa vyžadujú kolíky vhodné do materiálu, z ktorého je stena vyrobená.
- TR** Güvenliğinizi için: Mobilyanın duvara sabitlenmesi  
Dikkat, sabitleme işlemi uzman biri tarafından yapılmalıdır çünkü bu işlem için duvarınızın malzemesine uygun dübellerin kullanılması gerekmektedir
- GR** Για την ασφάλειά σας : στερέωση των επίπλων στον τοίχο.  
Προσοχή, η στερέωση πρέπει να γίνεται από ικανό άτομο, καθώς απαιτούνται σφήνες προσαρμοσμένες στη φύση του τοίχου σας.

### اللغة العربية

لسلامتك الشخصية: تثبيت قطعة الأثاث على الحائط  
تحذير، يجب أن يقوم شخص متخصص بعملية التثبيت على الحائط إذ أنها تتطلب اسفينا  
معينا يتوافق مع طبيعة الحائط نفسه.

9

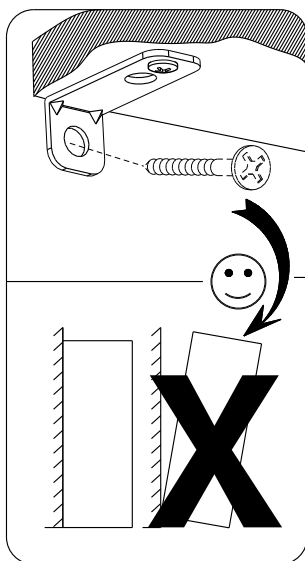
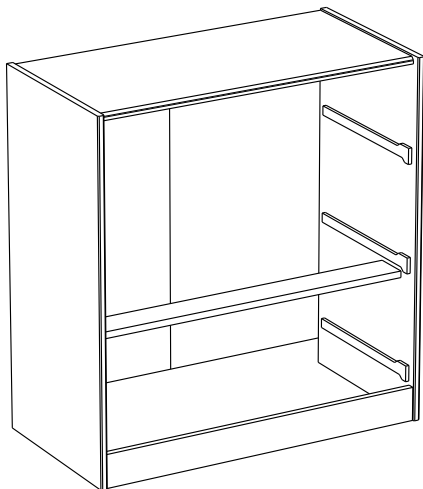

10

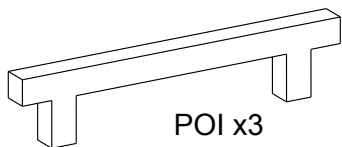
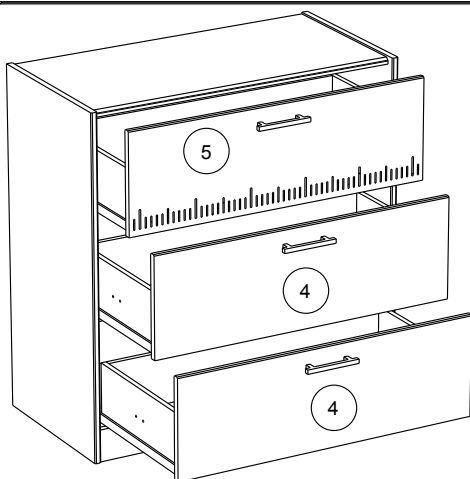

POI x3

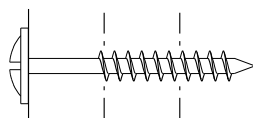

WH x 6

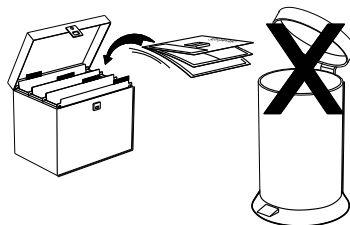

Faites un geste pour l'environnement en triant vos déchets d'emballage  
 Make a gesture for the environment by sorting out your waste of packaging  
 Machen Sie eine Bewegung für die Umwelt, ihre Verpackungsabfälle sortierend  
 Haga un gesto para el medio ambiente escogiendo sus residuos de embalaje

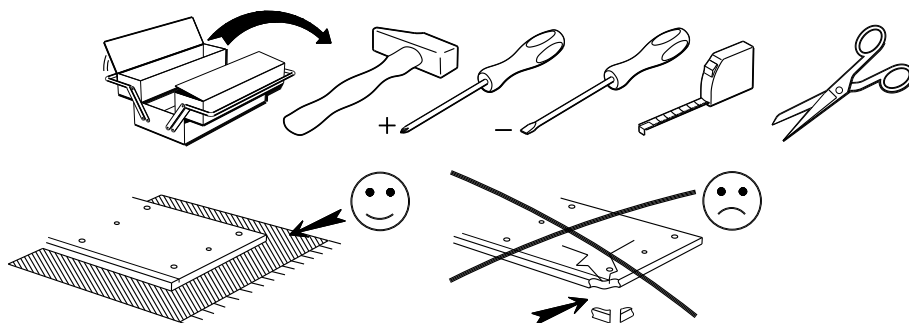
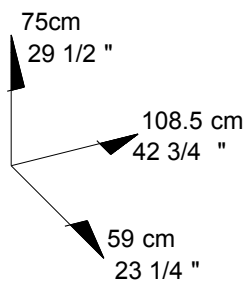
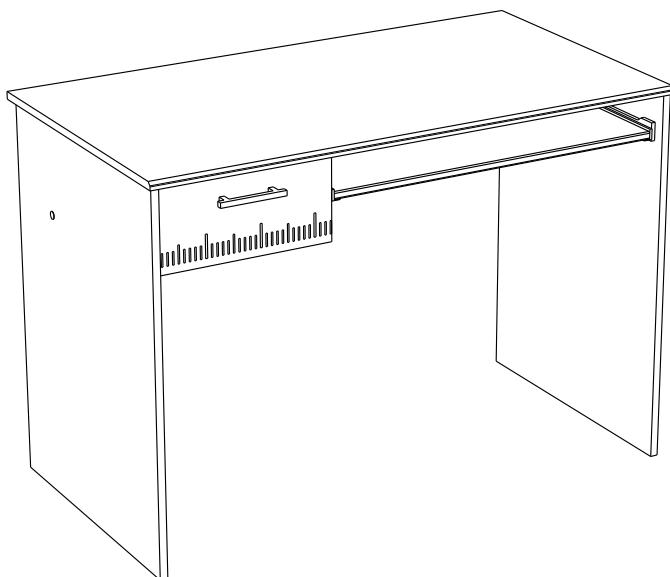

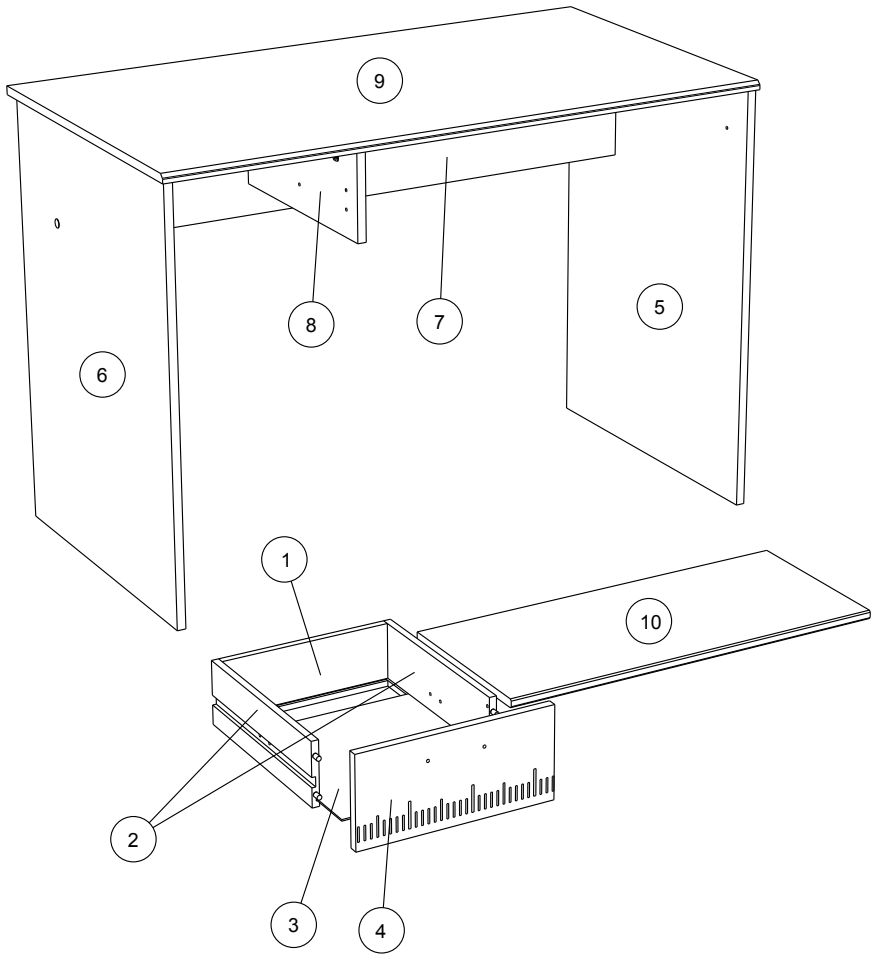

		mm			inch		
④	x 1	339	158	15	13 3/8	6 1/4	9/16
⑧	x 1	382	157	15	15	6 3/16	9/16
⑩	x 1	679	295	15	26 3/4	11 5/8	9/16
⑤	x 1	735	557	15	28 15/16	21 15/16	9/16
⑥	x 1	735	557	15	28 15/16	21 15/16	9/16
⑦	x 1	1047	211	15	41 1/4	8 5/16	9/16
⑨	x 1	1085	593	15	42 11/16	23 3/8	9/16
②	x 2	335	110	13	13 3/16	4 5/16	1/2
①	x 1	294	110	13	11 9/16	4 5/16	1/2
③	x 1	334	304	3	13 1/8	11 15/16	1/8

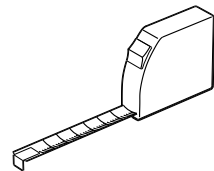



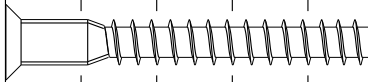
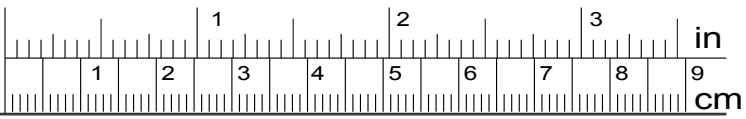

HW x4

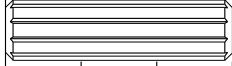

ADM x10



ADU x4



BSD x4

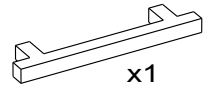

x1

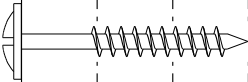

WH x 2



WA x2



HV x1

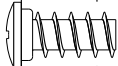

VB x6

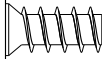

BWF x4



Ai x4



BLL x 4

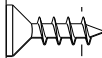

VG x11

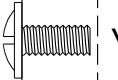

VR x2

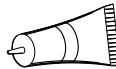

CF x1



Ci x2

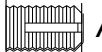

ANK x4

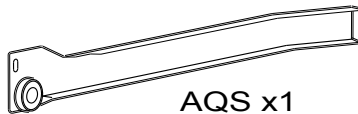

AQS x1

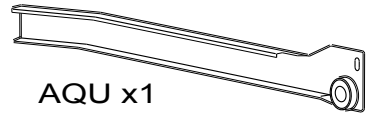

AQU x1

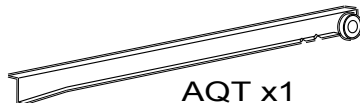

AQT x1

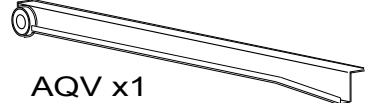

AQV x1

1

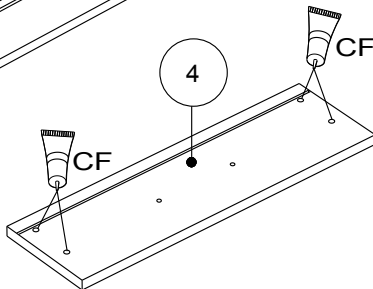
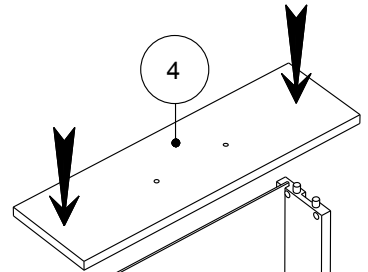
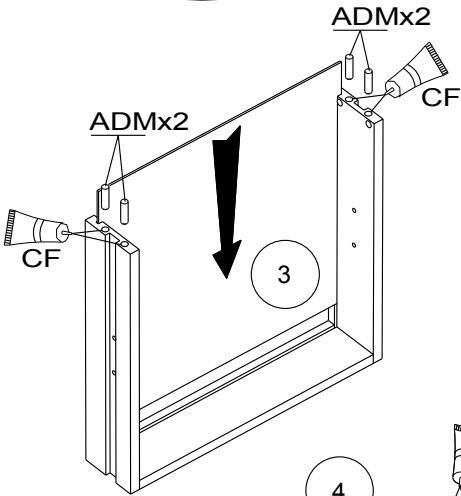
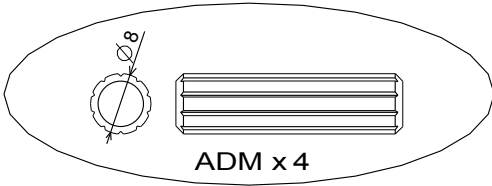
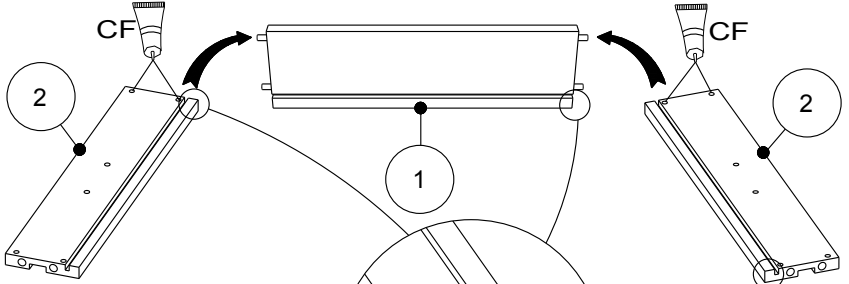
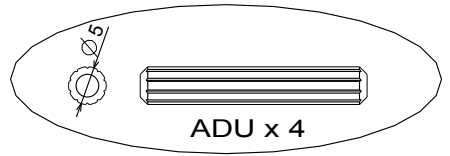
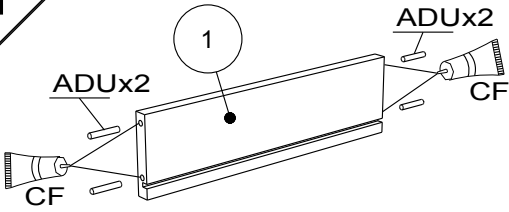

2

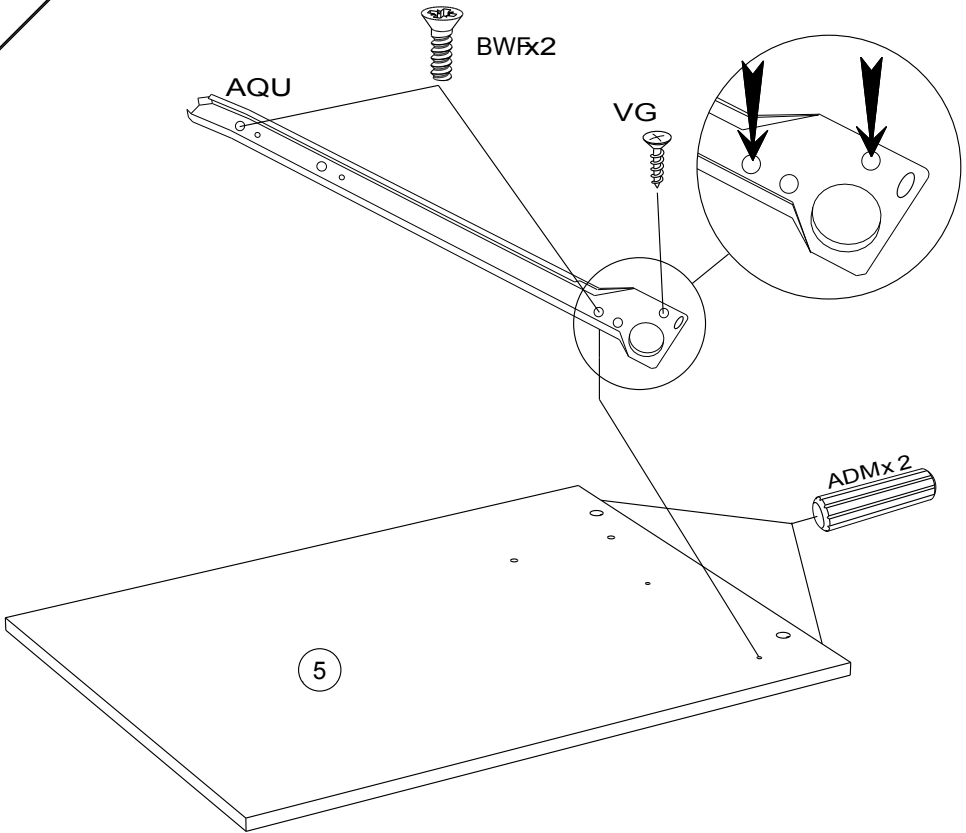

3

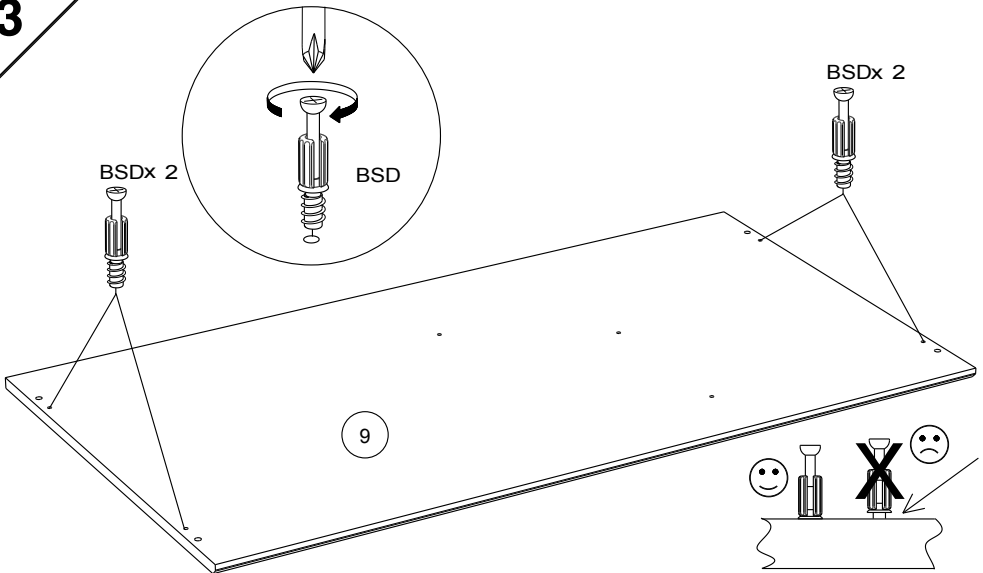

4

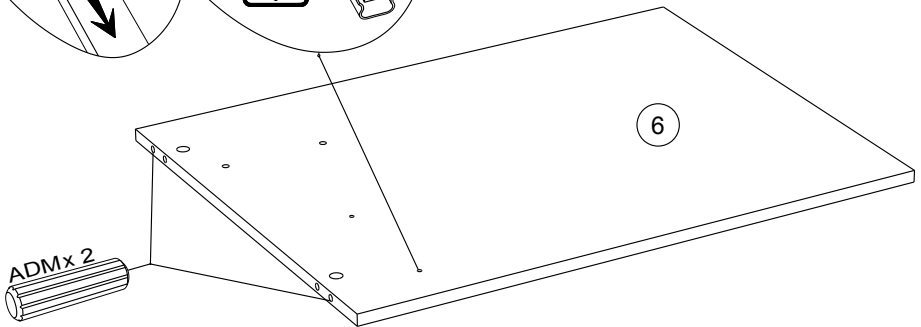
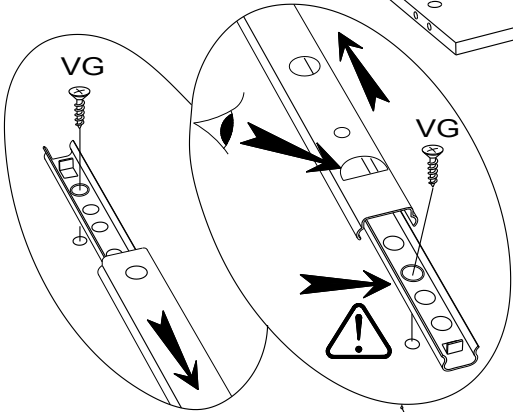
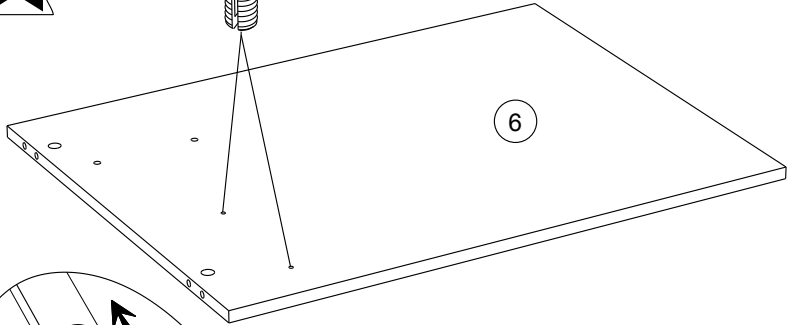
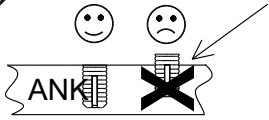

5

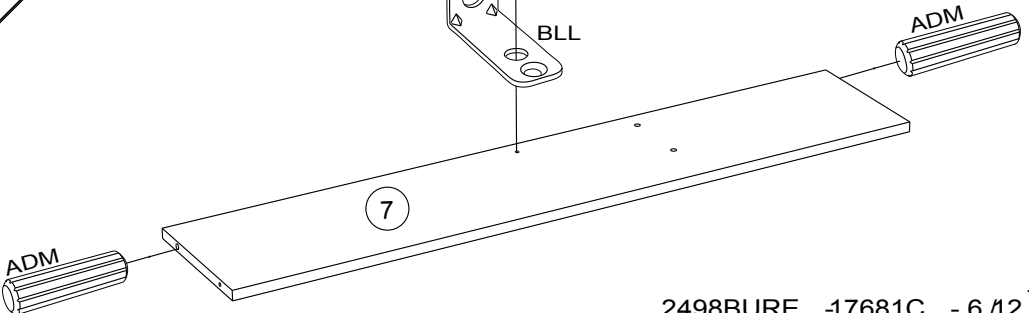
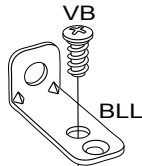

6

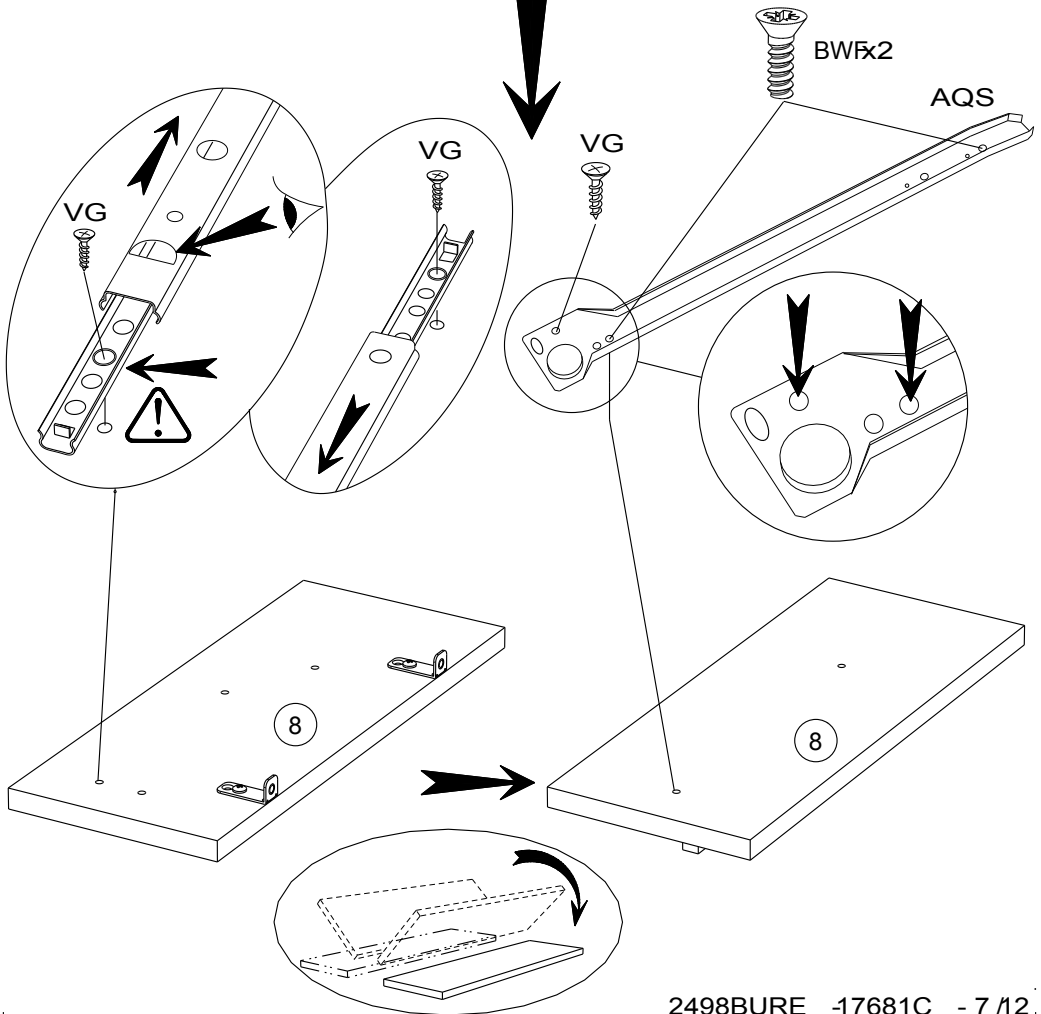
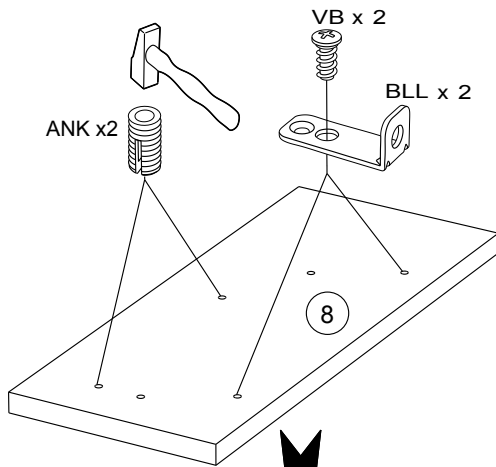

7

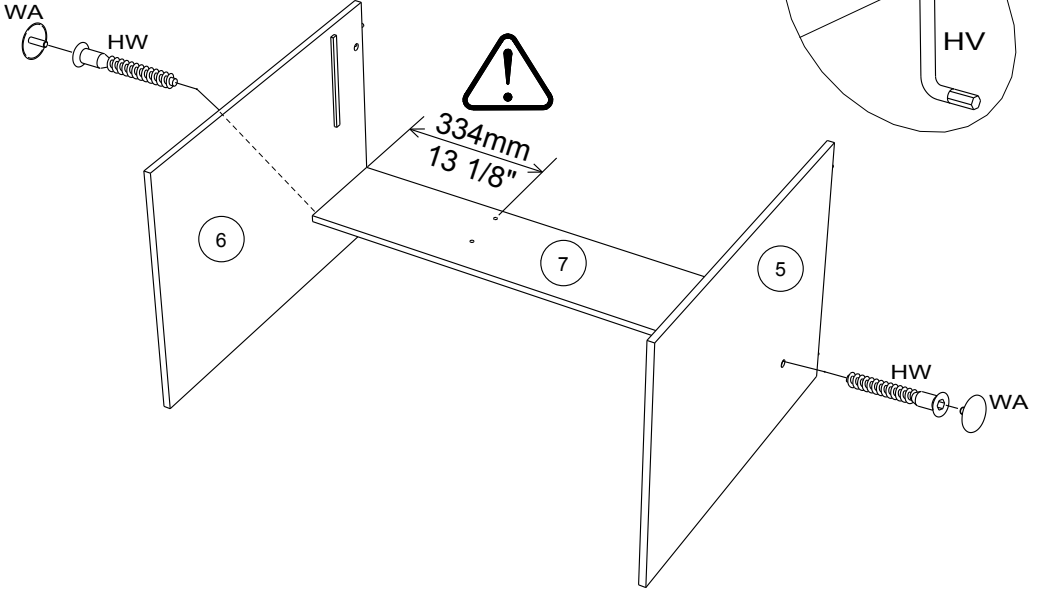

8

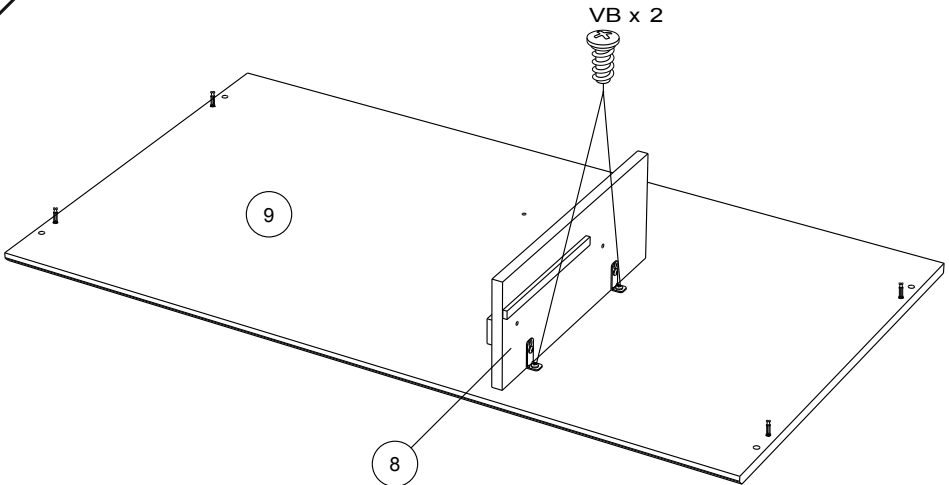

9

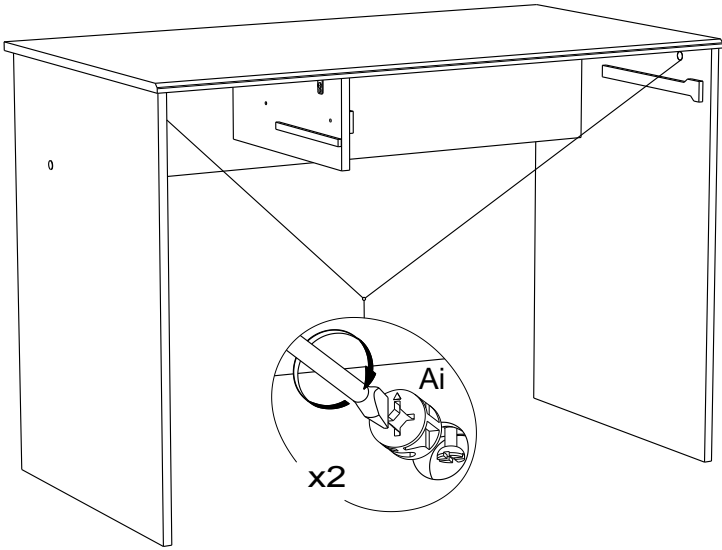

10

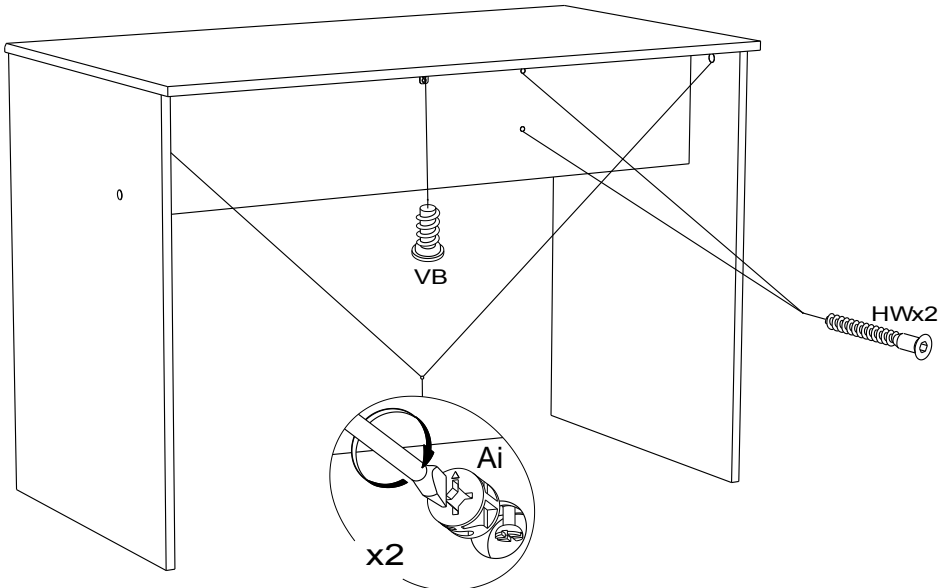

11

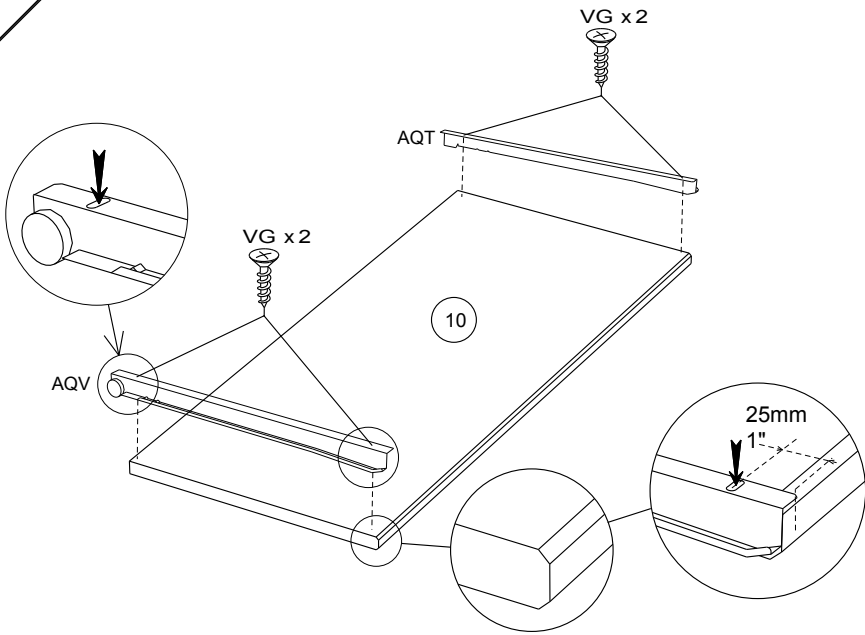

12

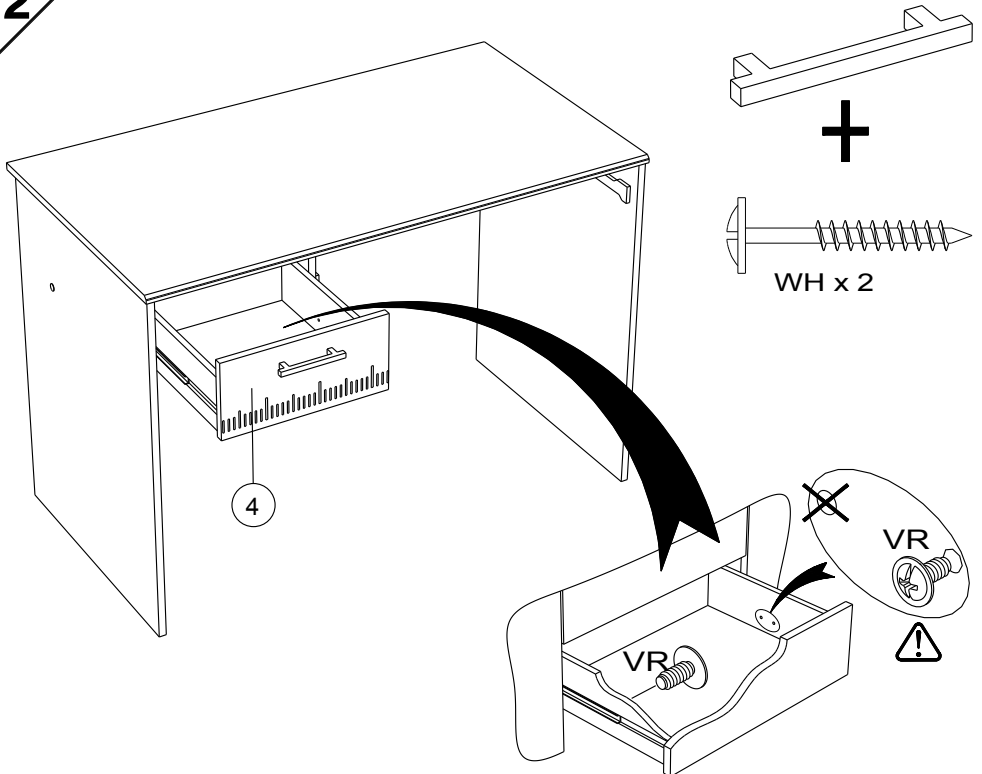

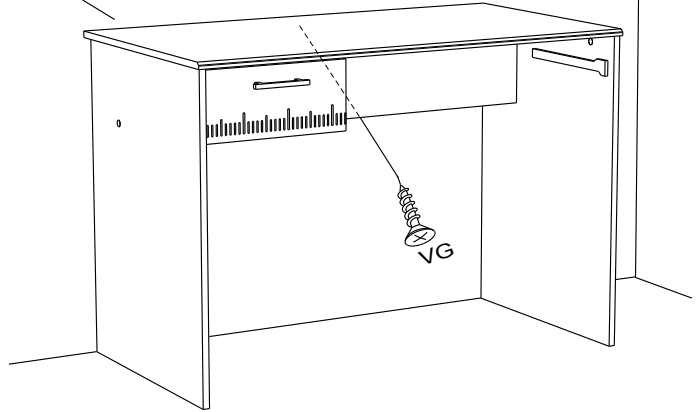
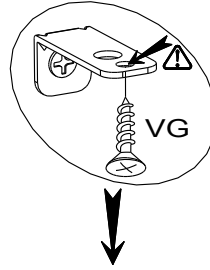
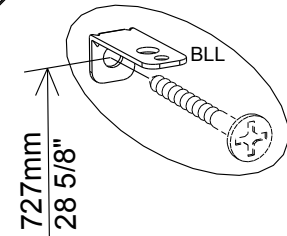

**13**

- FR** Pour votre sécurité : Fixation du meuble au mur  
Attention, la fixation doit être réalisée par une personne compétente car cela nécessite des chevilles adaptées à la nature de votre mur.
- GB** For your own safety: attach the furniture to the wall  
Important! The furniture must be attached by a qualified person using dowels that are suited to the type of wall.
- D** Für Ihre Sicherheit: Befestigung des Möbelstücks an der Wand  
Achtung, die Befestigung muss von einem Fachmann vorgenommen werden, weil sie an die Wand angepasste Dübel erfordert.
- E** Para su seguridad: Fijación del mueble a la pared  
¡Ojo! La fijación deberá llevarla a cabo una persona competente ya que necesitará unos tacos adaptados a tipo de pared.
- PT** Para a sua segurança: Fixação do móvel na parede  
Atenção, a fixação deve ser efectuada por uma pessoa competente, pois exige a utilização de cavilhas adaptadas à natureza da parede.
- I** Per la vostra sicurezza: fissaggio del mobile alla parete.  
Nota bene, il fissaggio deve essere eseguito da personale specializzato, poiché l'utilizzo di tasselli adattati alla parete.
- NL** Voor uw veiligheid: bevestiging van het meubel aan de muur.  
Let op, de bevestiging moet worden uitgevoerd door een bevoegd persoon, want hiervoor zijn pluggen nodig die specifiek geschikt zijn voor de betreffende muur.

14

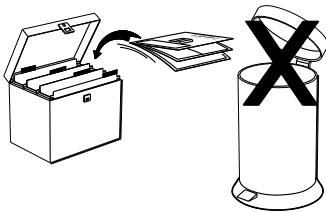
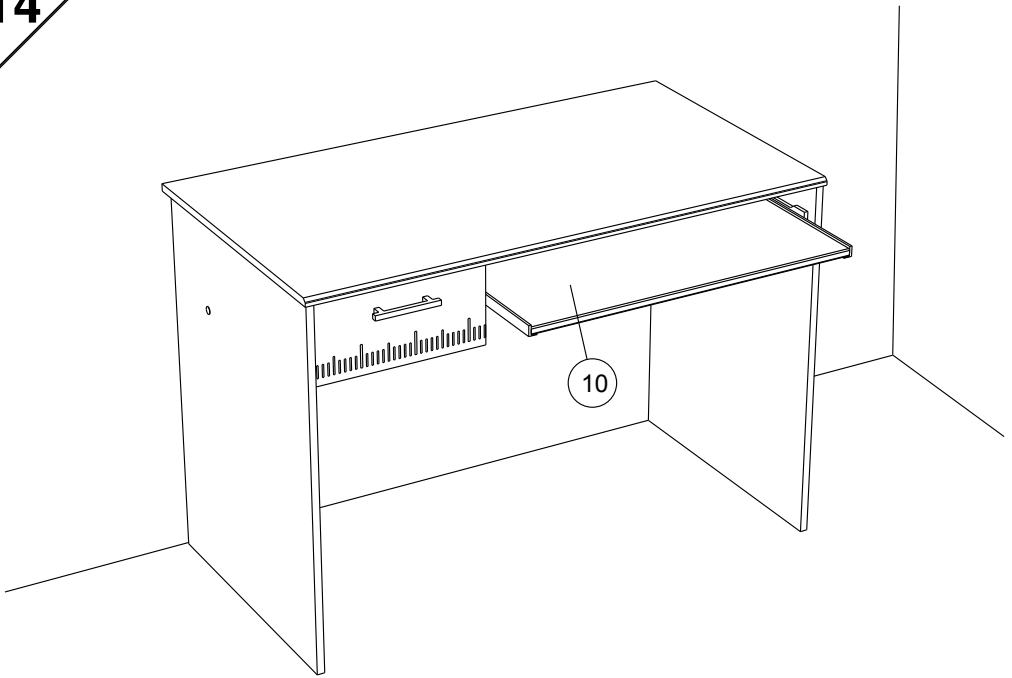

Faites un geste pour l'environnement en triant vos déchets d'emballage  
Make a gesture for the environment by sorting out your waste of packaging  
Machen Sie eine Bewegung für die Umwelt, ihre Verpackungsabfälle sortierend  
Haga un gesto para el medio ambiente escogiendo sus residuos de embalaje