

# LOWBOARD

model MBA06

MAX 30 KG  
MAX 66 LB

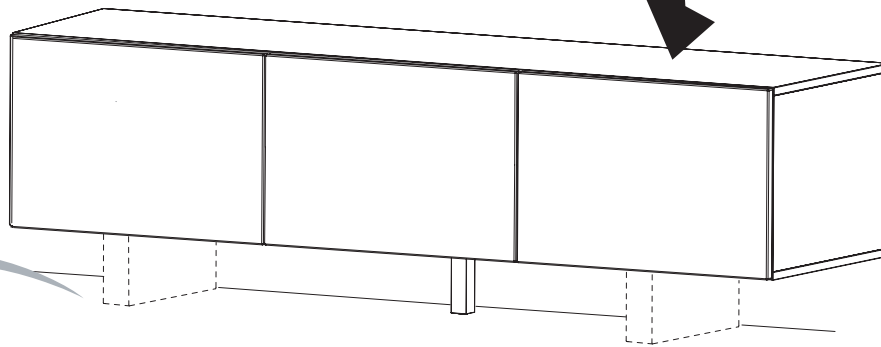

doors & legs  
cardboard box

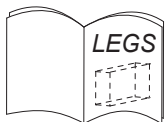



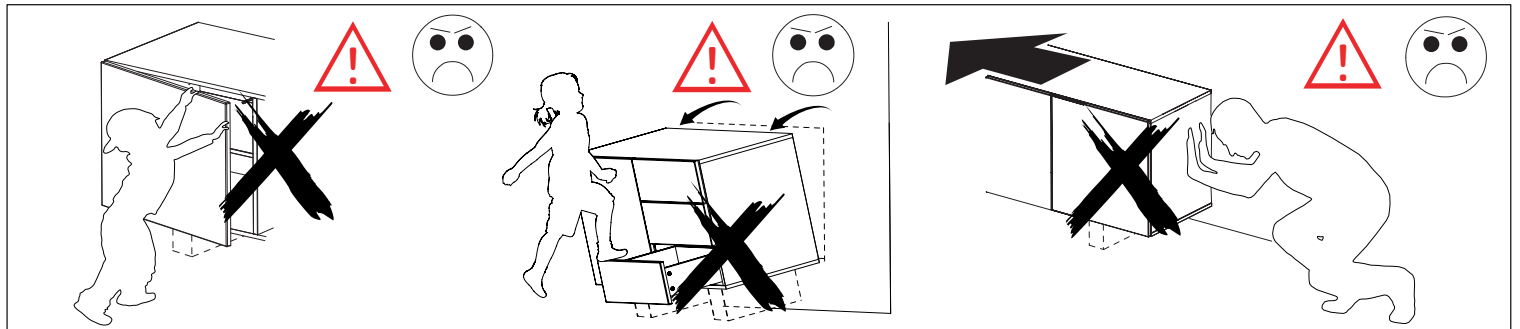

1648 x 704 x 471mm

64 <sup>7/8</sup> x 27 <sup>23/32</sup> x 18 <sup>35/64</sup> inches







## UK USA Safety instructions

The triangle reminds you during the installation of the following notes. 

-  8 Do not exceed the maximum loads specified. Otherwise, the furniture may sustain damage and be irreparable.
-  12 Ensure that children do not put any small parts such as nuts, caps or the like in their mouth. They could swallow and choke on them.
-  13 When assembling the product, please proceed with caution and comply with the assembly instructions.
-  19 Assembly should be carried out by a qualified person, because wrong assembly may lead to the furniture toppling over and causing injury or damage. As wall materials vary, screws for fixing to wall are not included. For advice on suitable screw systems, contact your local specialized dealer.





## FR Avis de sécurité

Ces avis vous seront rappelés durant le montage par ce triangle. 

-  8 Ne pas dépasser la charge maximum indiquée, cela endommagerait le meuble irrémédiablement.
-  12 Tenir les enfants éloignés afin d'éviter qu'ils ne portent à la bouche des petites pièces; ils pourraient les avaler et s'étouffer.
-  13 Durant le montage de votre meuble veuillez procéder avec prudence et respecter les instructions de montage.
-  19 Le montage doit être effectué par une personne compétente. Un montage mal effectué peut provoquer la chute du meuble et blesser quelqu'un. Les vis et ferrures pour fixer le meuble au mur ne sont pas incluses. Choisissez des vis et ferrures adaptées au matériau de votre mur. En cas de doute, demandez conseil à un vendeur spécialisé.

## ES Avisos de seguridad

Durante el montaje del mueble, prestar atención al triángulo que informa sobre los siguientes avisos. 

-  8 No exceder los límites de carga aconsejados, para evitar daños al mueble.
-  12 Mantener alejado de los niños piezas de herramientas como tornillos, ecc para evitar una eventual asfixia.
-  13 Seguir escrupulosamente el diagrama de montaje.
-  19 El montaje debe ser realizado por una persona competente. Un montaje incorrecto puede causar que los muebles se caigan y lesionen a alguien. Los tornillos y herrajes para fijar los muebles a la pared no están incluidos. Elija tornillos y herrajes adecuados para el material de su pared. En caso de duda, consulte a un distribuidor especializado.

## GB USA Assembly instructions

## DE Montageanleitung

10-2020

## FR Notice de montage

## ES Instrucciones de montaje

## NL Handleiding voor de montage

## RPC 安全 说明

## CZ Montážní návod

## PL Instrukcja montażu

## TR Montaj talimatı

## RU Инструкция по монтажу

## PT Instruções de montagem

## IT Istruzioni di montaggio

**diventa**  
think smart

**Service • Assistenza • Dienstverlening • Serwis  
Servis • Szerviz • Сервисная служба • 服務**

Name	Lowboard
Number	<b>MBA06</b>
Type	<b>3 doors</b>

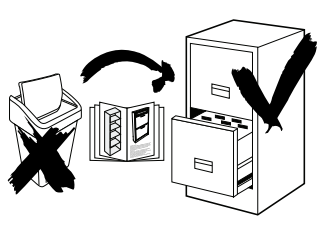
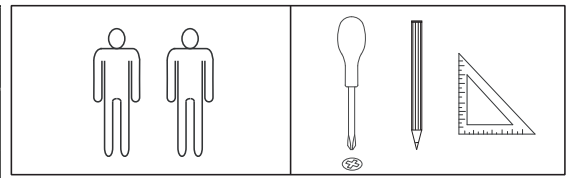
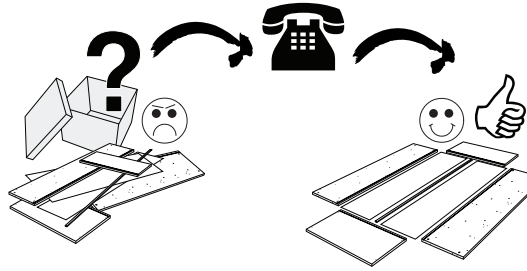
10-2020

**BEFORE STARTING, REFER TO THE ASSEMBLING ADVICE IN ANNEX**  
**BEVOR MIT DEM ZUSAMMENBAU ANGEFANGEN WIRD, BITTE DIE BEIGEFÜGTEN MONTAGEANWEISUNGEN LESEN**  
**AVANT DE COMMENCER, LIRE LES INSTRUCTIONS DE MONTAGE EN ANNEXE**  
**PRIMA DI COMINCIARE IL MONTAGGIO, LEGGERE LE ISTRUZIONI IN ALLEGATO**  
**LEA LAS INSTRUCCIONES ADJUNTAS ANTES DE COMENZAR EL ENSAMBLE**  
 在開始組裝之前，請閱讀附帶的說明

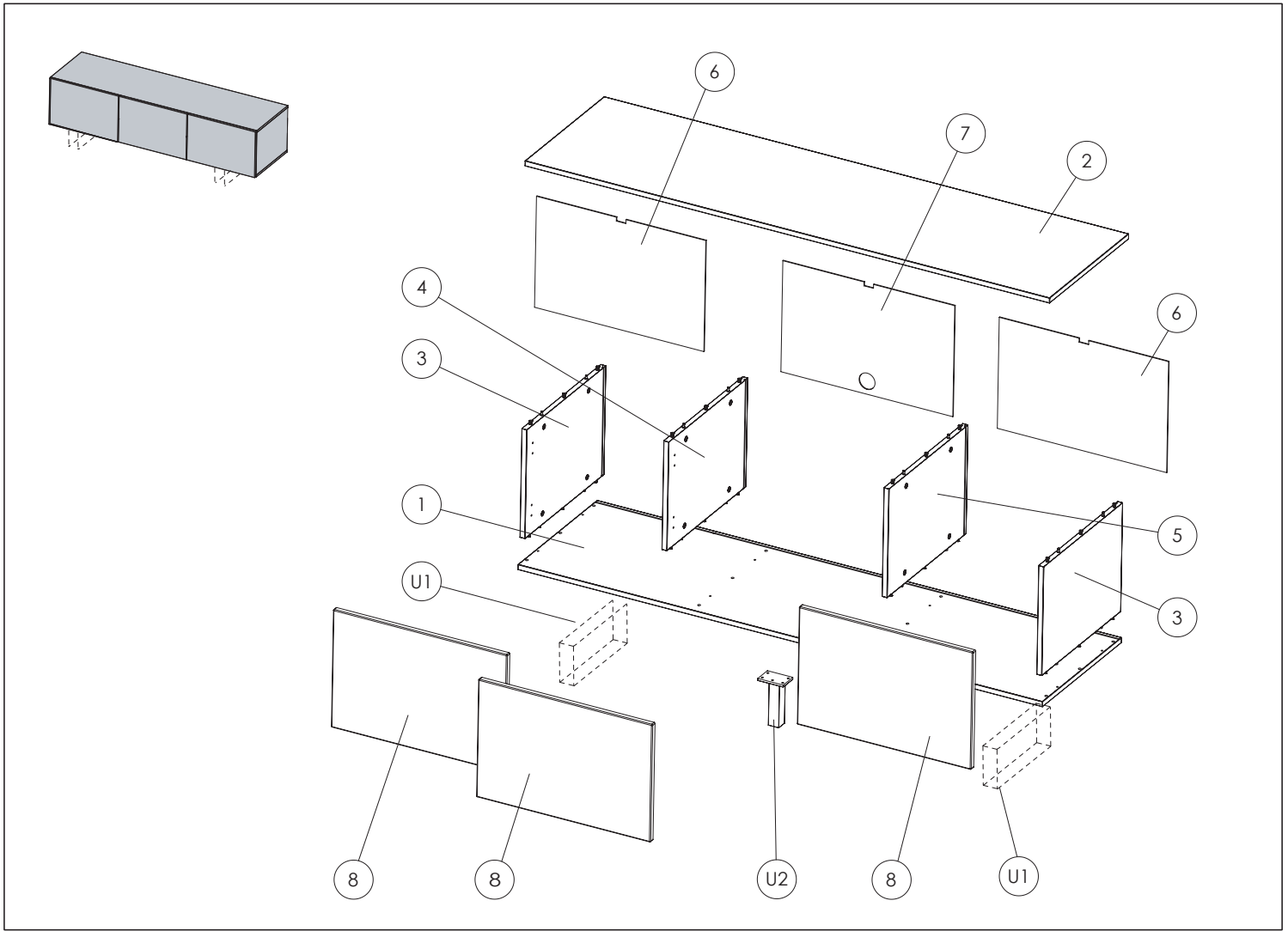

nr°	q_ty	length mm	length inch	width mm	width inch	thickness mm	thickness inch	box nr°
1	1	1648	64,88	454	17,87	16	0,63	1-2
2	1	1648	64,88	454	17,87	16	0,63	1-2
3	2	336	13,23	453	17,83	16	0,63	1-2
4	1	336	13,23	453	17,83	16	0,63	1-2
5	1	336	13,23	453	17,83	16	0,63	1-2
6	2	532	20,94	526	20,71	3	0,12	1-2
7	1	540	21,26	526	20,71	3	0,12	1-2
8	3	364	14,33	547	21,54	16	0,63	2-2

U1	2							2-2
U2	1	150	5,91	32	1,26	32	1,26	2-2

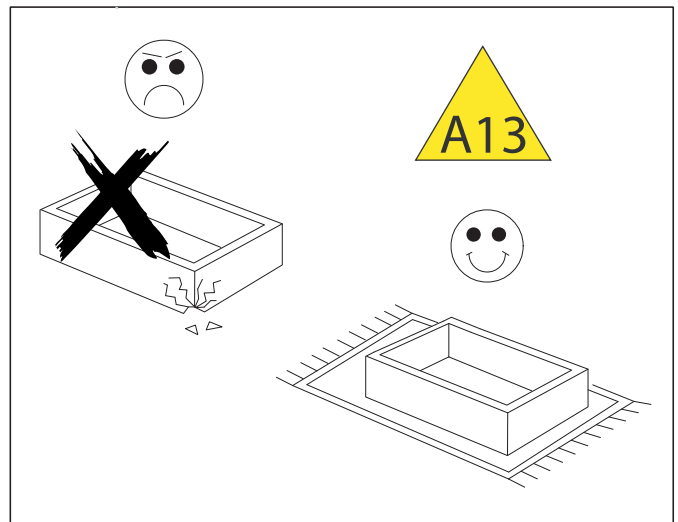

## UK USA Safety instructions

The triangle reminds you during the installation of the following notes.



8

Do not exceed the maximum loads specified. Otherwise, the furniture may sustain damage and be irreparable.

12

Ensure that children do not put any small parts such as nuts, caps or the like in their mouth. They could swallow and choke on them.

13

When assembling the product, please proceed with caution and comply with the assembly instructions.

19

Assembly should be carried out by a qualified person, because wrong assembly may lead to that the furniture toppling over and causing injury or damage. As wall materials vary, screws for fixing to wall are not included. For advice on suitable screw systems, contact your local specialized dealer.

## FR Avis de sécurité

Ces avis vous seront rappelés durant le montage par ce triangle.



8

Ne pas dépasser la charge maximum indiquée, cela endommagerait le meuble irrémédiablement.

12

Tenir les enfants éloignés afin d'éviter qu'ils ne portent à la bouche des petites pièces ; ils pourraient les avaler et s'étouffer

13

Durant le montage de votre meuble veuillez procéder avec prudence et respecter les instructions de montage.

19

Le montage doit être effectué par une personne compétente. Un montage mal effectué peut provoquer la chute du meuble et blesser quelqu'un. Les vis et ferrures pour fixer le meuble au mur ne sont pas incluses. Choisissez des vis et ferrures adaptées au matériau de votre mur. En cas de doute, demandez conseil à un vendeur spécialisé.

## ES Avisos de seguridad

Durante el montaje del mueble, prestar atención al triángulo que informa sobre los siguientes avisos.



8

No exceder los límites de carga aconsejados, para evitar daños al mueble.

12

Mantener alejado de los niños piezas de herramientas como tornillos, etc para evitar una eventual asfixia.

13

Seguir escrupulosamente el diagrama de montaje.

19

El montaje debe ser realizado por una persona competente. Un montaje incorrecto puede causar que los muebles se caigan y lesionen a alguien. Los tornillos y herrajes para fijar los muebles a la pared no están incluidos. Elija tornillos y herrajes adecuados para el material de su pared. En caso de duda, consulte a un distribuidor especializado.

## DE Sicherheitshinweise

Das Dreieck erinnert Sie während der Montage an die folgenden Hinweise.



8

Überschreiten Sie nicht die angegebenen Maximalbelastungen. Andernfalls kann das Möbelstück beschädigt oder zerstört werden.

12

Achten Sie darauf, daß Kinder keine Kleinteile, wie z. B. Muttern, Abdeckkappen oder Ähnliches in den Mund nehmen. Sie könnten sie verschlucken und daran ersticken.

13

Gehen Sie bei der Montage des Artikels sorgfältig vor und halten Sie sich an die Montageanleitung.

19

Fachkundige Montage erforderlich. Unsachgemäße Montage kann zu Unfällen führen. Da es viele verschiedene Wandmaterialien gibt, sind Schrauben für die Wandbefestigung nicht beigelegt. Ggf. sollte man sich beim Eisenwarenfachhandel nach geeignetem Befestigungsmaterial erkundigen.

## IT Avvisi di sicurezza

Durante il montaggio del mobile, il triangolo segnala i seguenti avvisi.



8

Non superare i limiti di carico suggeriti, per evitare il danneggiamento del mobile.

12

Tenere lontano dai bambini pezzi di ferramenta come viti, copriviti ecc. per evitare un eventuale soffocamento.

13

Seguire scrupolosamente lo schema di montaggio.

19

Il montaggio deve essere effettuato da personale qualificato. Se non viene effettuato correttamente, il prodotto può ribaltarsi o cadere, danneggiando persone o cose. Poiché ci sono pareti di materiali diversi, le viti per il fissaggio alla parete non sono incluse. Per scegliere gli accessori di fissaggio adatti, rivolgeti a un rivenditore locale.

## RU Правила техники безопасности

Во время монтажа треугольник служит напоминанием для следующих указаний.



8

Не допускается превышение указанных максимальных нагрузок. В противном случае возможно повреждение или разрушение мебели.

12

Следите, чтобы мелкие детали, например гайки, крышки и т. п., не попали в рот ребенка. Дети могут их проглотить и задохнуться.

13

При монтаже изделия будьте внимательны и соблюдайте инструкции по монтажу.

19

Монтажът трябва да бъде извършен от специалист, тъй като неправилният монтаж може да доведе до прекатурване и да причини нараняване или повреда. Поради разнообразието от стени материали винтовете за прикрепяне към стената не са осигурени. Свържете се със специализиран доставчик за съвет относно подходящи прикрепващи механизми.

## TR Güvenlik uyarıları

Durante a montagem do móvel, o triângulo indica as seguintes advertências.



Belirtilen azami yük değerini aşmayınız, aksi takdirde mobilya parçası zarar görebilir veya kullanılamaz hale gelebilir.



Çocukların somun, muhafaza kapakçıkları ve benzeri küçük parçaları ağızlarına almamalarına dikkat ediniz. Bunları yutabilirler ve boğulabilirler.



Montaj esnasında büyük bir itinayla çalışınız, ürünle dikkatlice çalışınız ve mutlaka montaj talimatına uyunuz.



Montaj, yetkili bir kişi tarafından yapılmalıdır. Yanlış montaj mobilyanın düşmesine ve yaralanma veya hasara yol açabilir. Duvar yapı malzemeleri farklılık göstereceğinden duvar montajı vidaları dahil değildir. Uygun bir vida sistemi için ilgili araç-gerçerleri satan dükkanlara başvurunuz.

## NL Veiligheidsinstructies

De driehoek herinnert u tijdens de installatie van de volgende meldingen.



Overschrijd de aangegeven maximale belastingen niet. Anders kan het meubelstuk worden beschadigd of vernield.



Zorg ervoor dat kinderen geen kleine stukken, zoals moeren, afdekkapjes of dergelijke in de mond nemen. Ze kunnen ze inslikken en daardoor stikken.



Ga bij de montage van het artikel zorgvuldig te werk en houd u aan de handleiding voor de montage.



De montage dient te worden uitgevoerd door een vakbekwaam iemand. Foutieve montage kan ertoe leiden dat het meubel omvalt, waardoor er persoonlijk letsel of schade kan ontstaan. Omdat er veel verschillende wandmaterialen bestaan, zit er geen wandbeslag bijgesloten. Voor advies over geschikt wandbeslag, neem contact op met de vakhandel.

## CZ Bezpečnostní pokyny

Trojúhelník vám během montáže připomene následující pokyny.



Nepřekračujte uvedená maximální zatížení. V opačném případě může dojít k poškození nebo zničení nábytku.



Dbejte na to, aby děti nedávaly do úst žádné drobné díly jako např. matice, krytky a podobně. Mohly by je spolknout a udusit se.



Při montáži výrobku postupujte pečlivě a dodržujte pokyny uvedené v montážním návodu.



Montáž by měla být provedena kvalifikovanou osobou - nesprávné provedení může vést k převrnutí nábytku a způsobit úraz nebo destrukci. Pro různé zdící materiály nejsou šroubky a uchycení obsaženy v balení. O vhodném přípevnění se poraďte s odborným prodejcem.

## RPC 安全说明

在家具組裝期間，三角形會提醒您注意事項



不要超过规定的最大载荷。否则，家具可能会受损或受到不可挽回的损坏



确保任何小零件，如螺母，盖帽等类似硬物远离儿童。否则他们可能会吞下并导致窒息



组装产品时，请谨慎操作并遵守装配说明



装配应由合格人员进行。错误的装配可能导致家具翻倒并造成伤害或损坏。由于墙壁材料不同，不包括用于固定到墙壁的螺钉。有关合适的螺丝系统的建议，请联系您当地的专业经销商。

## PL Wskazówki bezpieczeństwa

Trójkąt przypomina o następujących wskazówkach dotyczących montażu.



Nie wolno przekraczać podanych maksymalnych wartości obciążenia. W przeciwnym razie mebel może zostać uszkodzony lub zniszczony.



Należy dopilnować, aby dzieci nie bawiły się lub też brały do ust żadnych drobnych części mebla, takich jak np. nakrętki, zatyczki itp.. Mogłyby je połknąć i udusić się nimi.



Podczas montażu proszę postępować z należytą uwagą i zgodnie z instrukcją montażu. Artykuł może być montowany tylko przez osoby z odpowiednimi kwalifikacjami.



Montaż powinien być przeprowadzany przez wykwalifikowaną osobę, ponieważ złe zmontowanie może spowodować zniszczenie mebla lub może wyrządzić szkodę domownikom. Ponieważ w każdym pomieszczeniu ściany mogą być wykonane z innego materiału, komplet nie zawiera żadnych wkrętów ani umocowań. Aby zasięgnąć porady w kwestii wyboru odpowiednich wkrętów skontaktuj się z lokalnym sklepem specjalistycznym.

## PT Avisos de segurança

Durante a montagem do móvel, o triângulo indica as seguintes advertências.



Não ultrapasse os limites de carga recomendados, para evitar danos no móvel.



Mantenha longe do alcance das crianças todo o tipo de peças pequenas como parafusos e outras, para evitar o risco de sufocamento.



Siga escrupulosamente o esquema de montagem.



Montaje a realizar por montador autorizado, pues un montaje erróneo puede resultar en una caída del mueble, causando daños a personas o cosas. Como hay muchas clases de materiales de pared, no se incluyen los tornillos de montaje. Para sugerencias sobre sistemas de colocación adecuados, ponte en contacto con tu especialista más cercano.

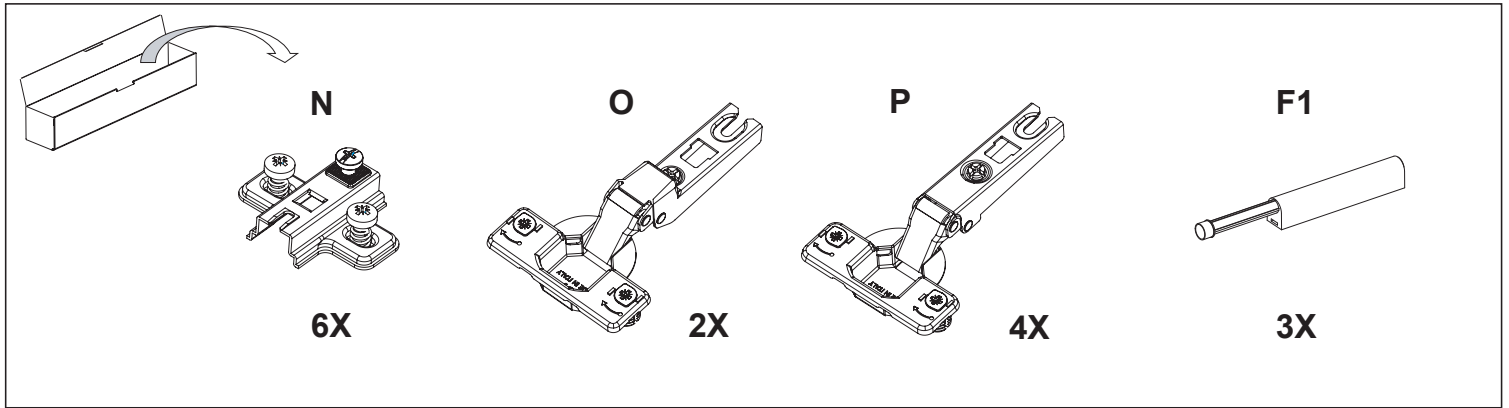
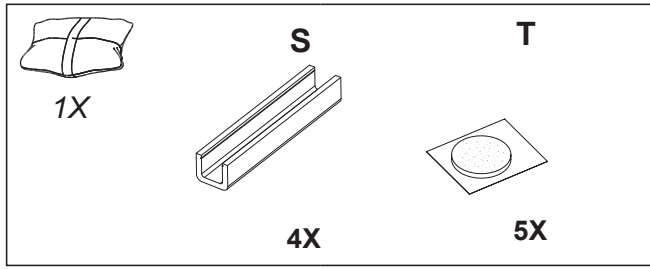
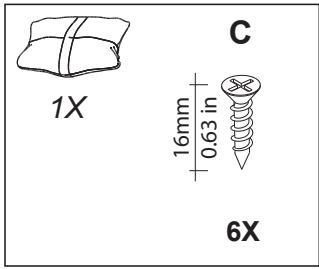
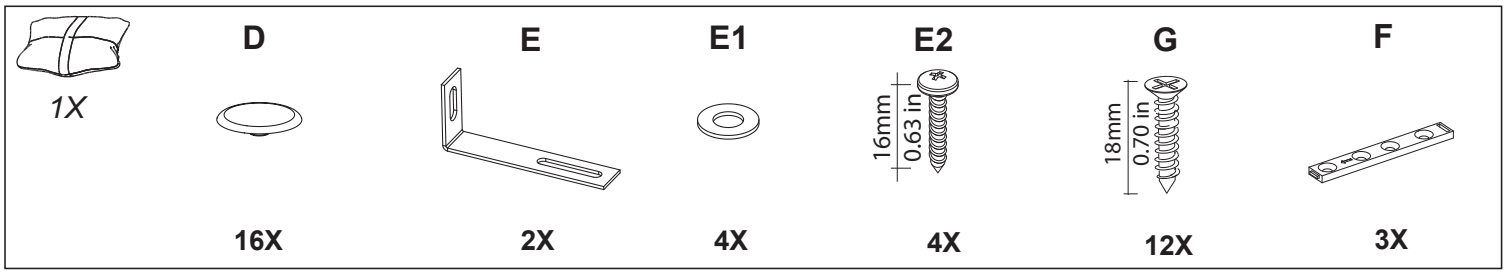

1

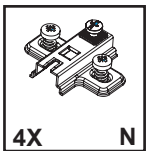

4X N

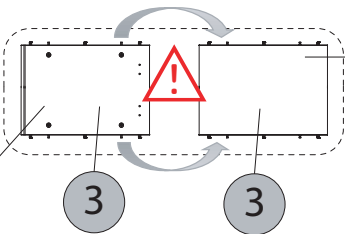

front view  
Vorderansicht  
vue antérieure  
vista dal fronte  
Vooraanzicht  
前視圖

rear view  
Rückansicht  
vue postérieure  
vista dal retro  
Achteraanzicht  
從後面看

N

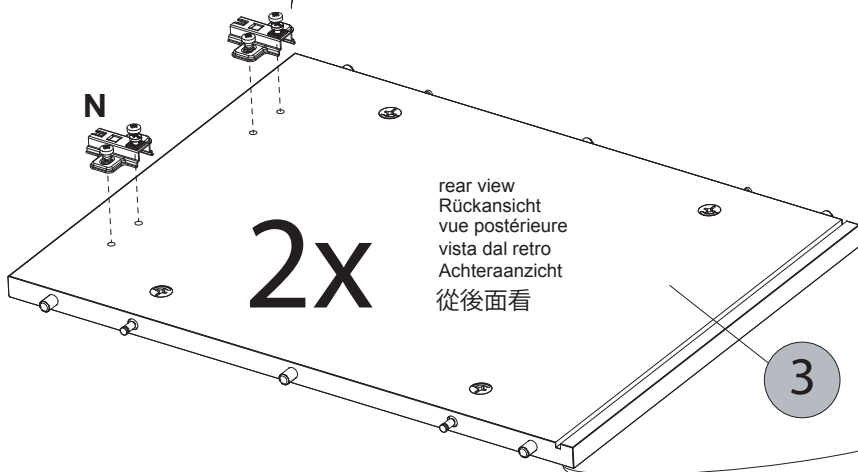

rear view  
Rückansicht  
vue postérieure  
vista dal retro  
Achteraanzicht  
從後面看

2x

3

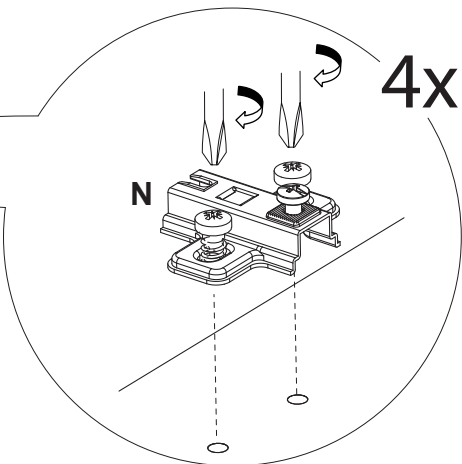

4x

N

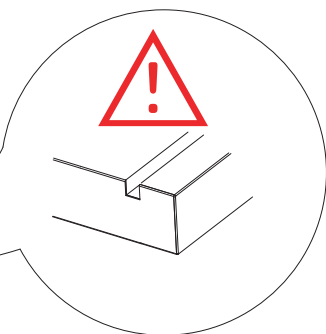

2

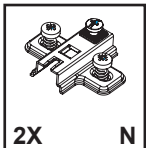

2X N

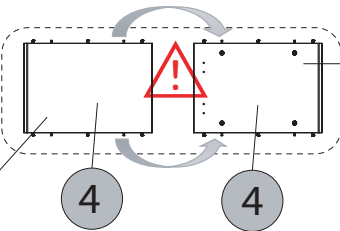

front view  
Vorderansicht  
vue antérieure  
vista dal fronte  
Vooraanzicht  
前視圖

rear view  
Rückansicht  
vue postérieure  
vista dal retro  
Achteraanzicht  
從後面看

N

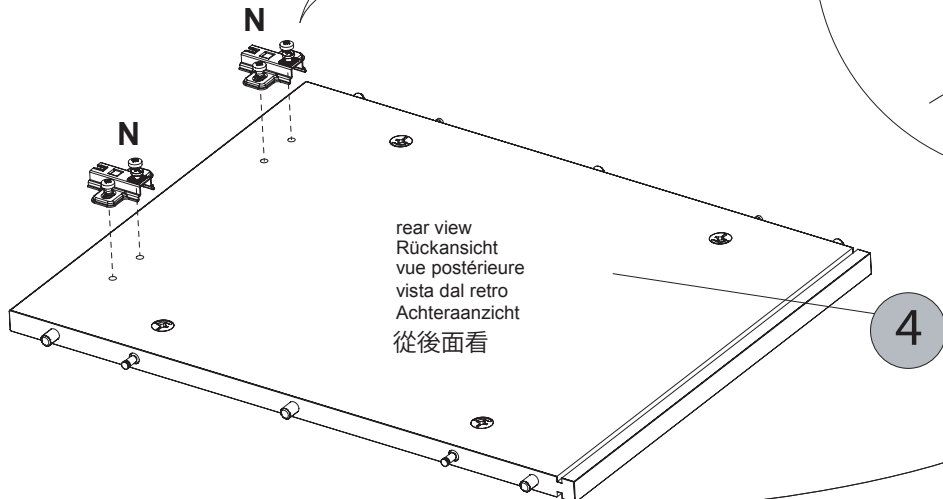

rear view  
Rückansicht  
vue postérieure  
vista dal retro  
Achteraanzicht  
從後面看

2x

4

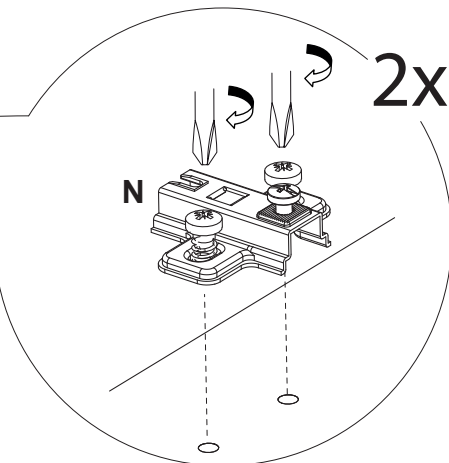

2x

N

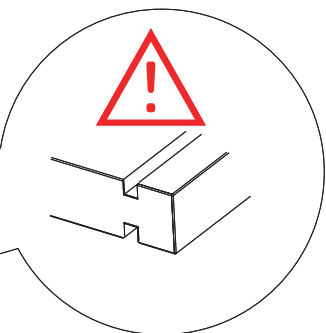

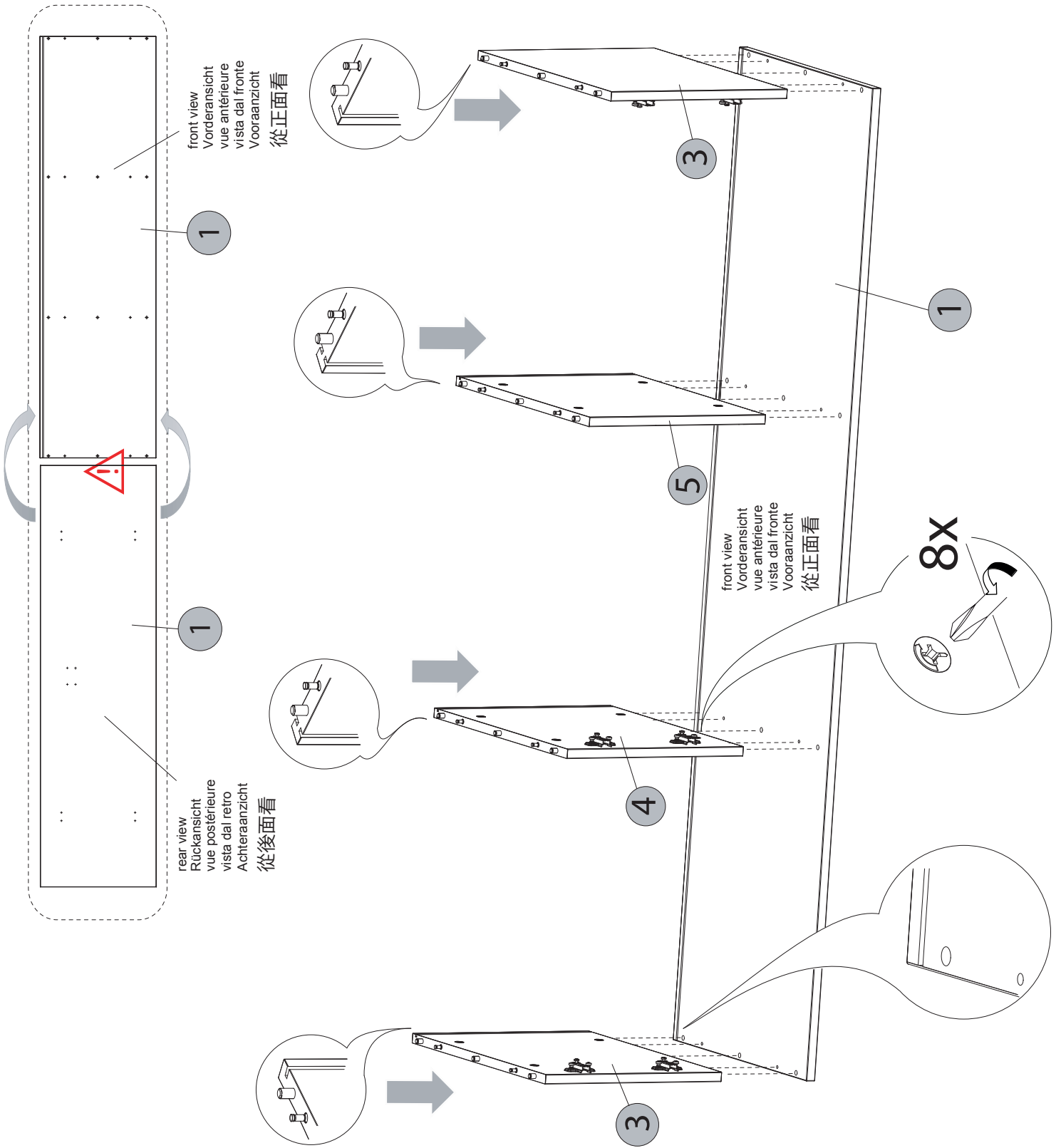





6

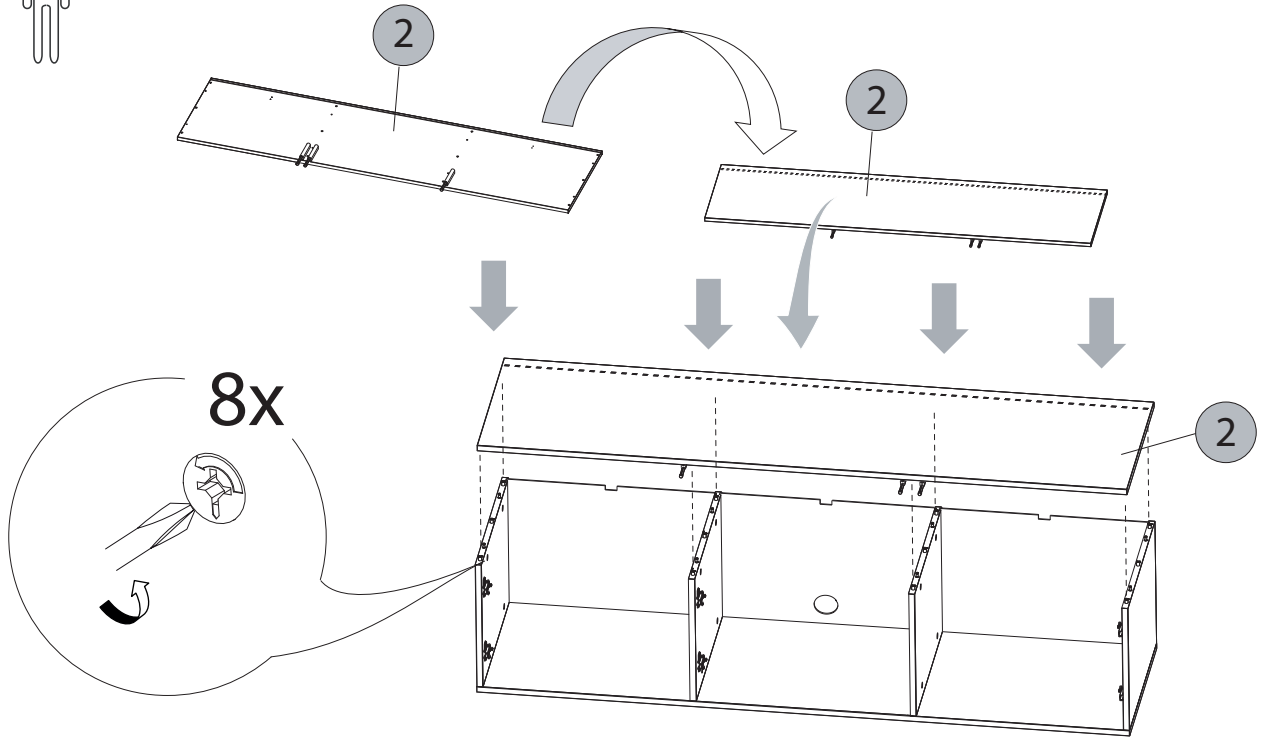
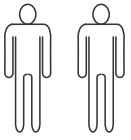

7

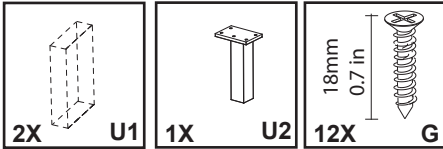

Cardboard box containing doors and legs

Caja de cartón con puertas y patas.

Carton contenant façades et pieds

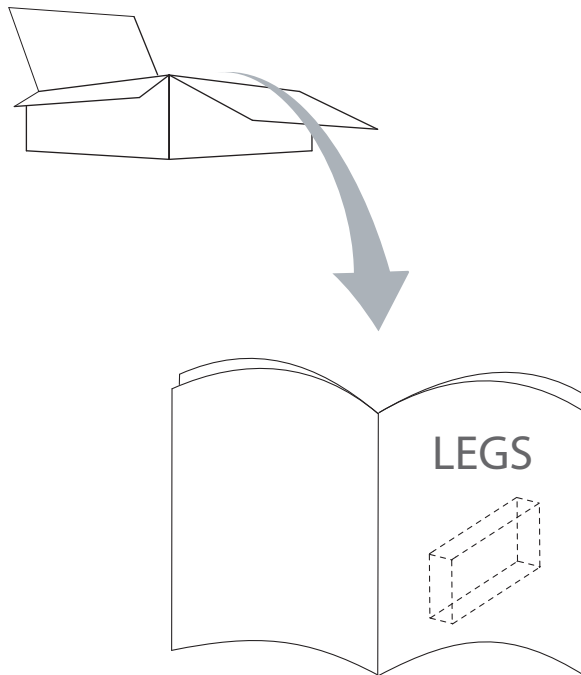

Karton mit Fronten und Fuessen

包含門和腿的☒板箱



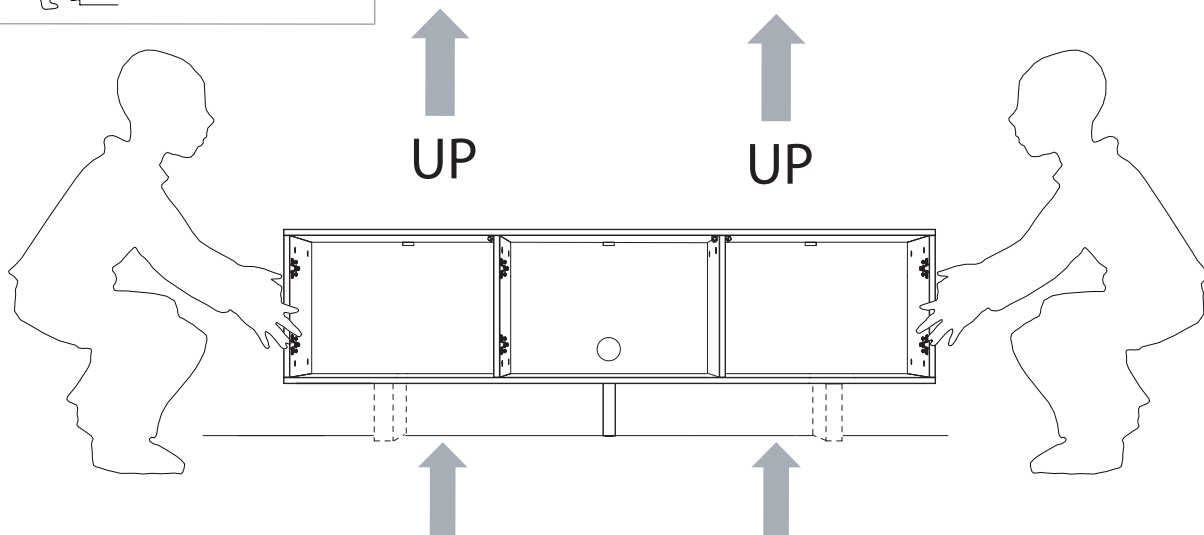
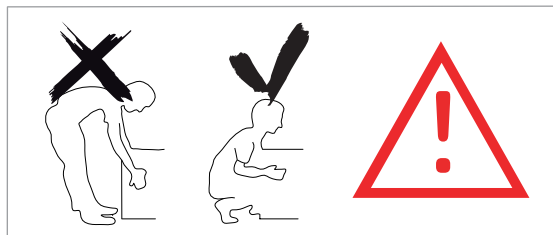
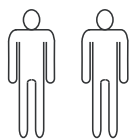







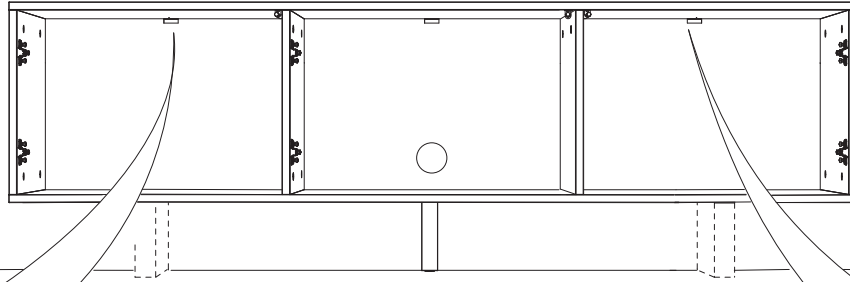





8



 <b>Achtung • Attention • Attenzione</b> <b>Opgelet • Uwaga • Pozor • Figyelem</b> <b>• Dikkat • Внимание</b> 	
(GB) (USA)	Always move carefully keeping the module raised off the ground in order not to damage the legs of the cabinet.
(FR)	Déplacez-vous toujours avec précaution en gardant le module surélevé afin de ne pas endommager les pieds du meuble.
(ES)	Muévase siempre con cuidado manteniendo el módulo elevado del suelo para no dañar las patas de los muebles.
(D)	Behandeln Sie das Modul immer vorsichtig und halten Sie es vom Boden abgehoben, um die Beine des Schrankes nicht zu beschädigen.
(IT)	Movimentare sempre con attenzione tenendo il modulo sollevato da terra al fine di non danneggiare le gambe del mobile.
(NL)	Beweeg de module altijd voorzichtig en houd deze van de grond af om de poten van de kast niet te beschadigen.
(RPC)	移动时一定要小心翼翼·将模块抬高离开地面·以免损坏机柜的支脚
(RU)	Всегда осторожно двигайтесь, удерживая модуль в поднятом положении, чтобы не повредить ножки шкафа.
(PL)	Moduł należy zawsze przesuwać ostrożnie, trzymając go uniesionego nad ziemią, aby nie uszkodzić nóg szafy
(SK)	Vždy sa pohybuje opatrne, modul držte zdvihnutý nad zemou aby ste nepoškodili nohy skrinky.
(CZ)	Vždy se pohybuje opatrne a udržujte modul zvednut ze zeme aby nedošlo k poškození nohou nábytku.
(TR)	Modülü yerden kaldırarak daima dikkatli hareket edin kabin ayaklarına zarar vermemek için.

9



 <b>Achtung • Attention • Attenzione</b> <b>Opgelet • Uwaga • Pozor • Figyelem</b> <b>Atenție • Dikkat • Внимание</b> 	
	Wall mounting instructions and warnings are particularly important and should not be changed, "Because wall materials vary, wall mounting screws are not included. Use the correct hardware for your wall construction."
	Les instructions de montage mural et les avertissements sont particulièrement importants et ne doivent pas être modifiés. "En raison de la diversité des matériaux utilisés, les vis de montage mural ne sont pas fournies. Utilisez le matériel approprié pour votre construction murale."
	Las instrucciones y advertencias para el montaje en la pared son particularmente importantes y no se deben cambiar, "Debido a que los materiales de la pared varían, los tornillos para el montaje en la pared no están incluidos. Use el hardware correcto para la construcción de su pared."
	Anweisungen und Warnungen für die Wandmontage sind besonders wichtig und sollten nicht geändert werden."
	Le istruzioni e le avvertenze per il montaggio a parete sono particolarmente importanti e non dovrebbero essere modificate, "Poiché i materiali delle pareti variano, le viti per il montaggio a parete non sono incluse. Usa l'hardware corretto per la tua costruzione a muro."
	Instructies voor wandmontage en waarschuwingen zijn bijzonder belangrijk en mogen niet worden veranderd: "Omdat muurmaterialen variëren, zijn muurbevestigingsschroeven niet inbegrepen. Gebruik de juiste hardware voor uw muurconstructie."
	牆面安裝說明和警告特別重要，不應更改， "因為牆壁材料不同，牆壁安裝螺釘不包括在內。使用正確的牆壁結構硬件。"
	Инструкции по установке на стену и предупреждения особенно важны и не должны изменяться: «Поскольку материалы для стен отличаются, винты для настенного монтажа не входят в комплект. Используйте правильное оборудование для вашей конструкции стены.»
	Instrukcje dotyczące montażu na ścianie i ostrzeżenia są szczególnie ważne i nie należy ich zmieniać. „Ponieważ materiały naścienne się zmieniają, wkręty do montażu na ścianie nie są dołączone. Użyj odpowiedniego sprzętu do budowy ściany.”
	Pokyny na montáž na stenu a upozornenia sú obzvlášť dôležité a nemali by sa meniť, "Pretože materiály na stenách sa líšia, skrutky na montáž na stenu nie sú súčasťou dodávky. Použite správny hardvér pre vašu stenovú konštrukciu."
	Pokyny pro montáž na stěnu a varování jsou obzvláště důležité a neměly by se měnit."
	Duvara montaj talimatları ve uyarıları özellikle önemlidir ve değiştirilmemelidir, "Duvar malzemeleri değişken olduğu için duvara montaj vidaları dahil değildir. Duvar konstrüksiyonunuz için doğru donanımı kullanın."



10

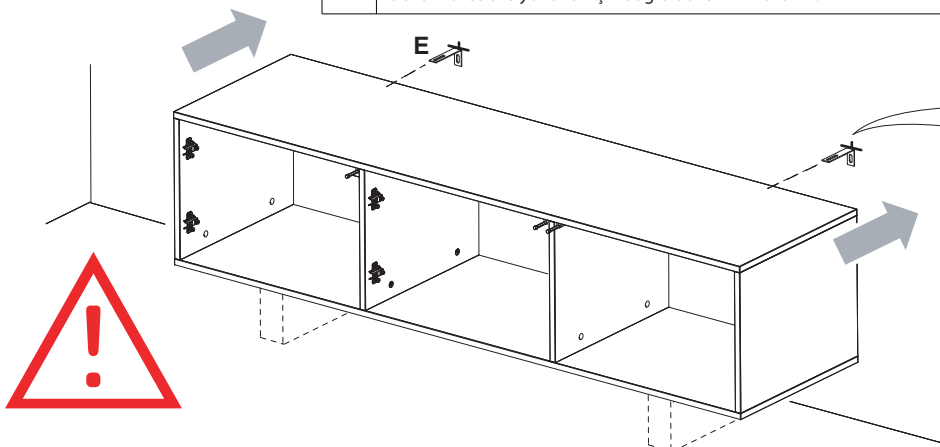
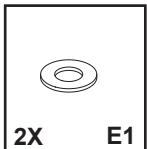
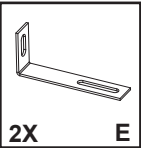
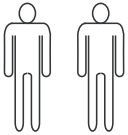

2x

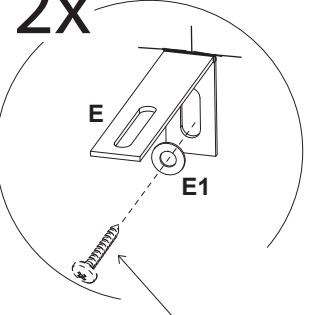

not included  
nicht inbegriffen  
non compris  
non incluso  
no incluido  
不包括在內

# 11

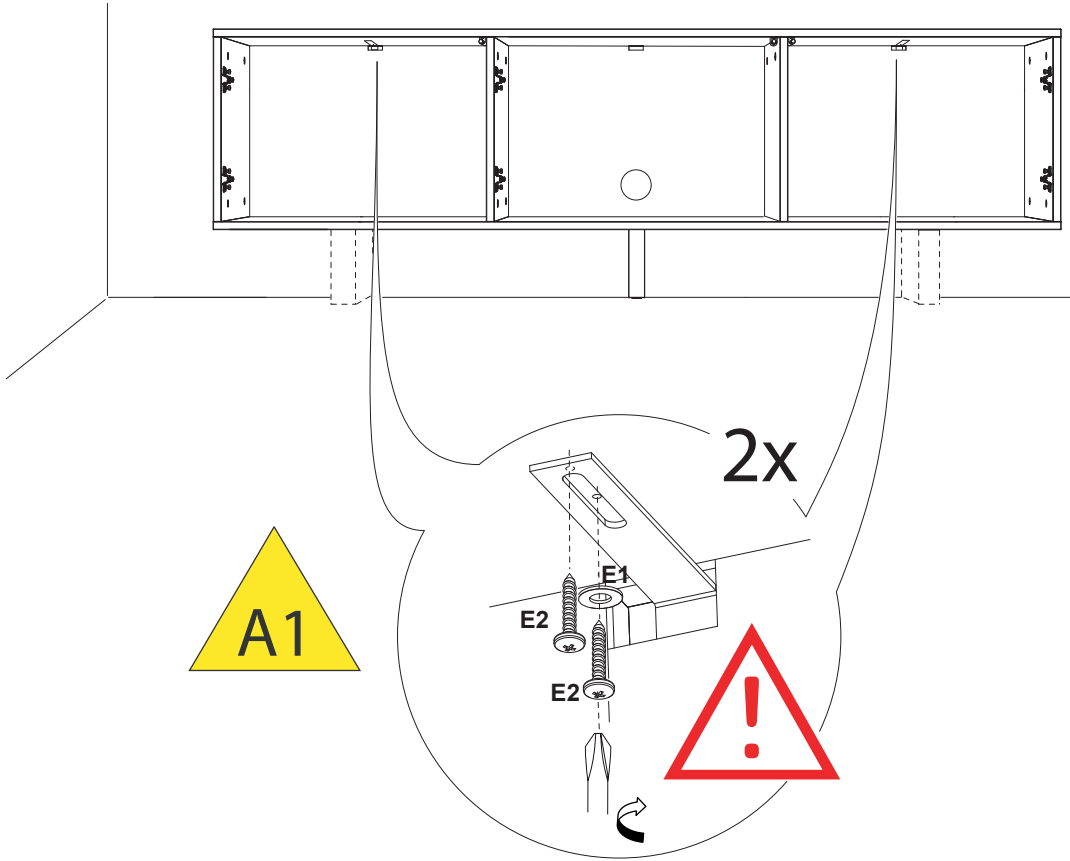
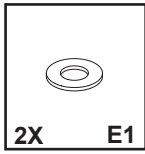
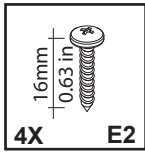

# 12

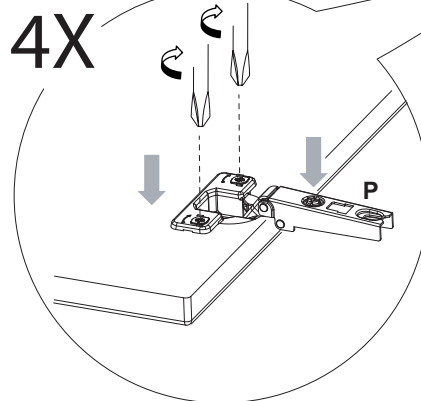
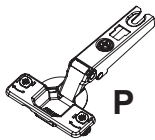
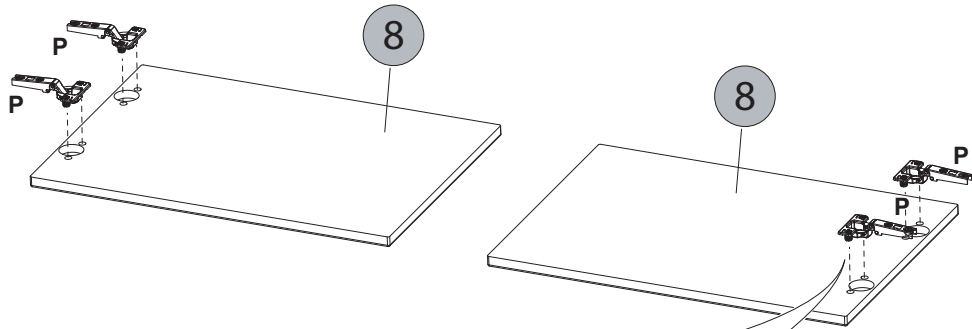
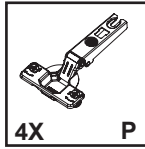

# 13

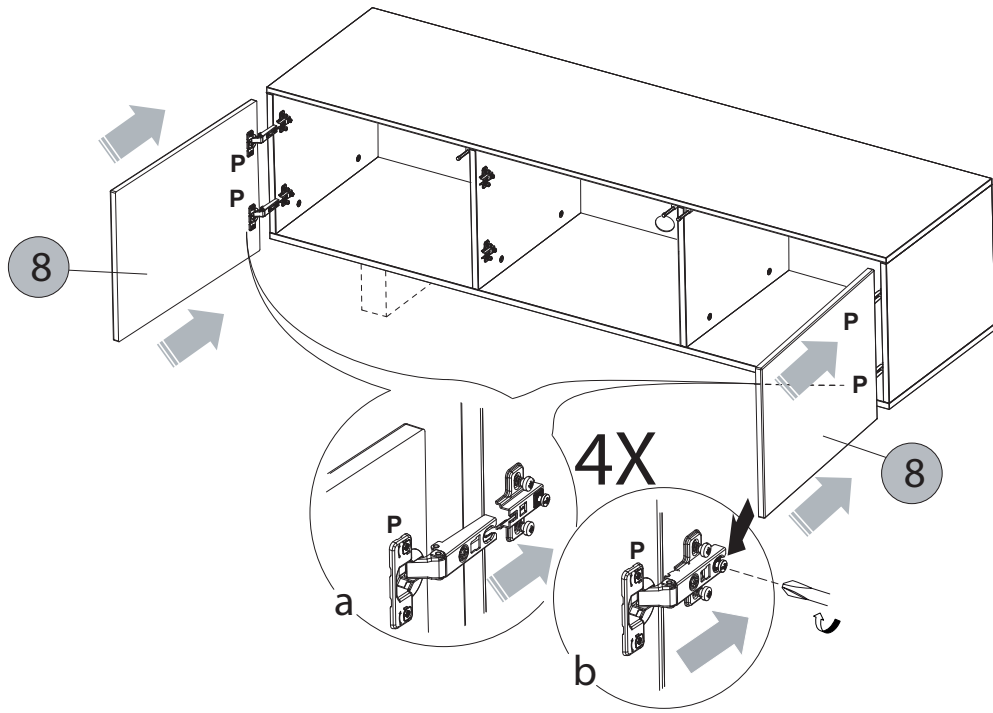

# 14

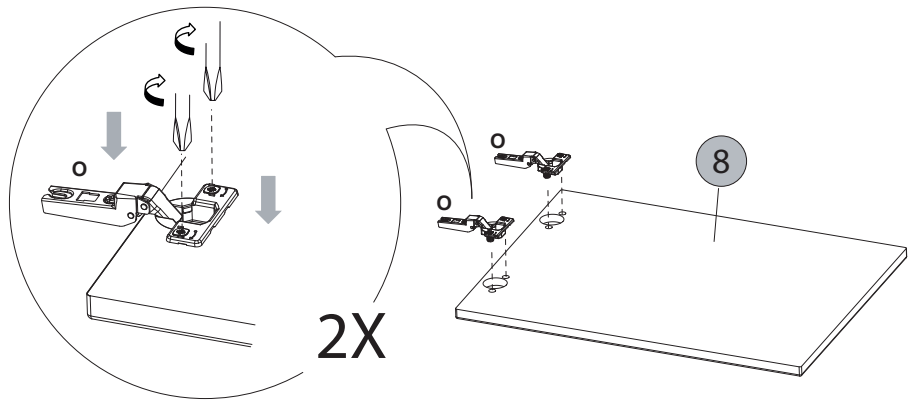
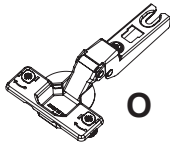
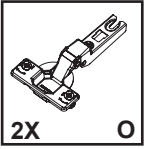

# 15

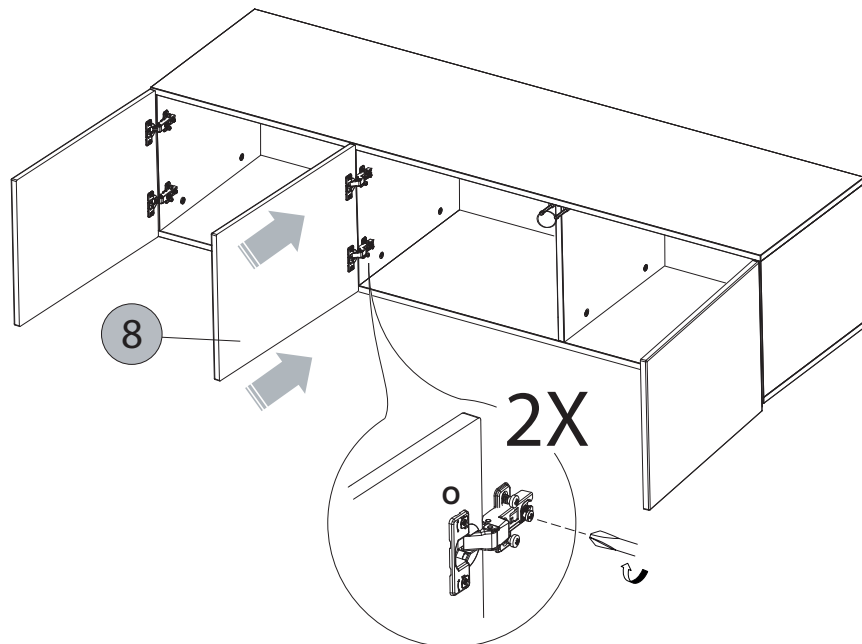

# 16

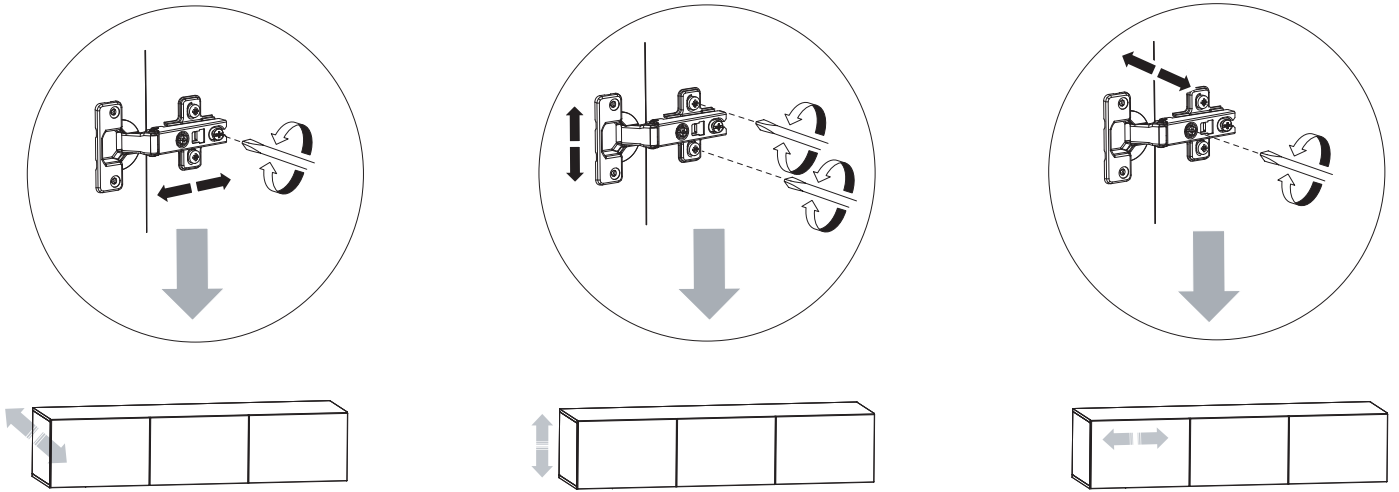

# 17

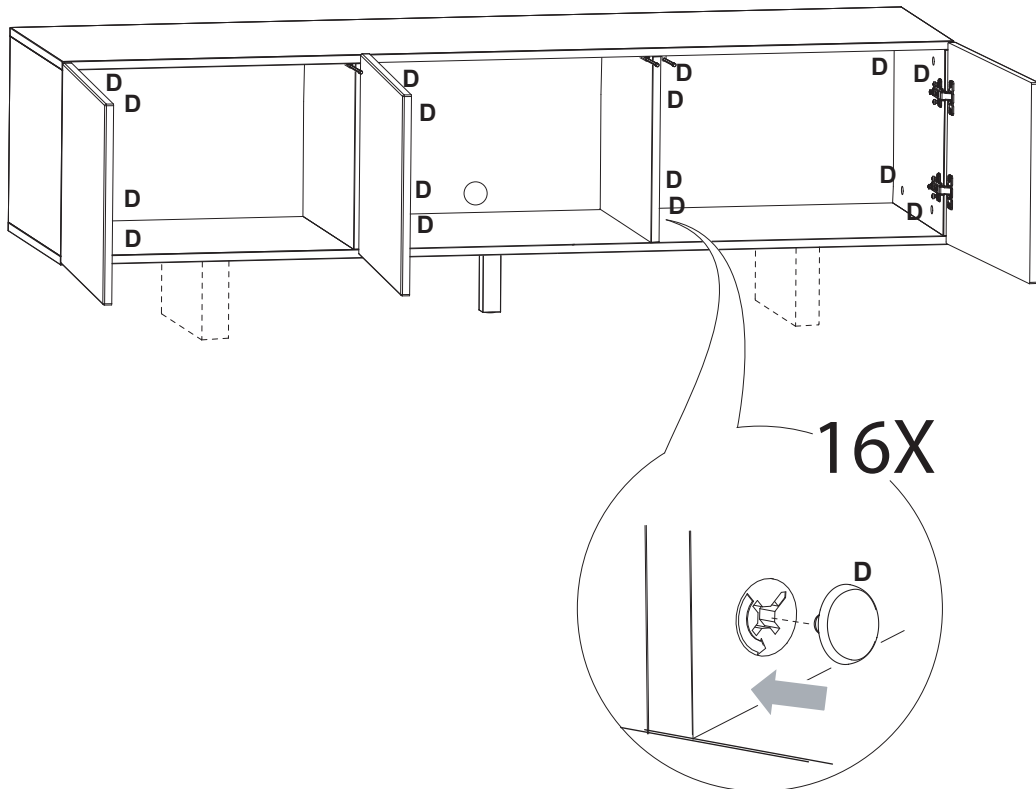
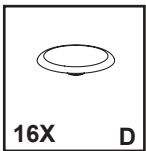

18

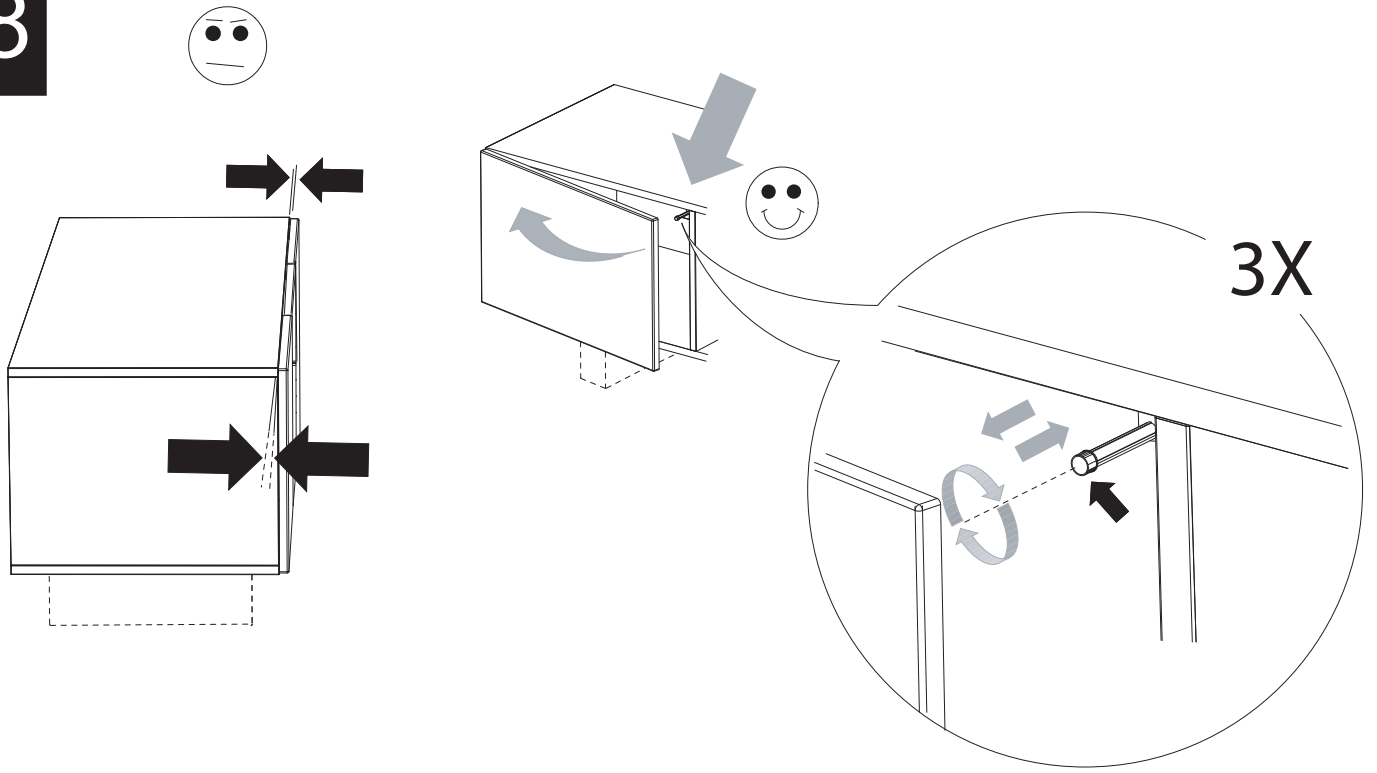

19

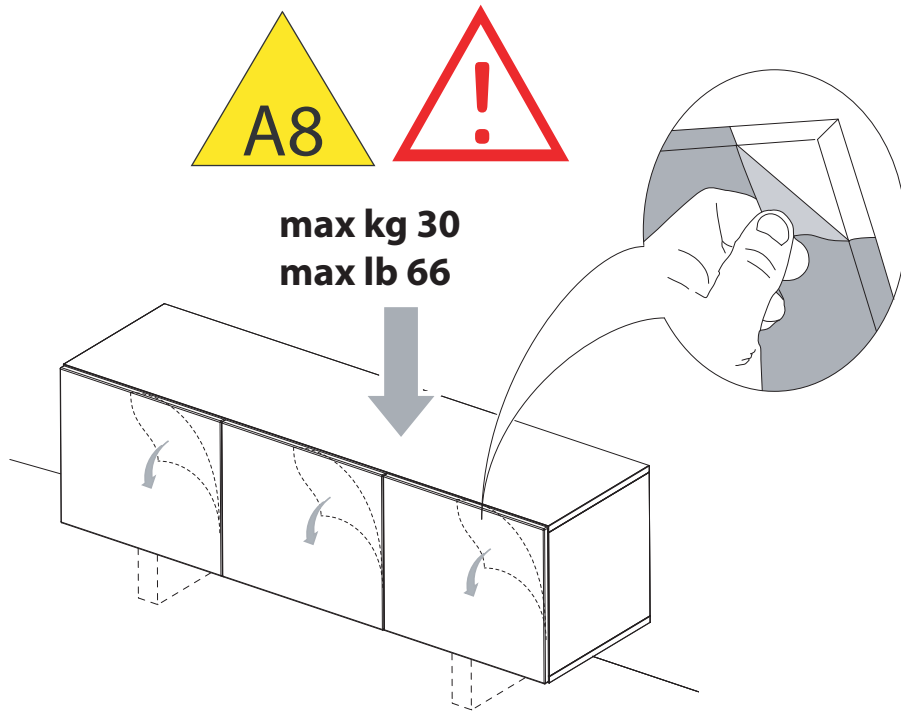

## **UK USA** Care tips

Please only clean with a duster or a damp cloth. Do not use any abrasive cleaners. In general, keep water away from your furniture (e. g. when mopping or watering plants). The moisture may penetrate the furniture and damage it.

## **ES** Alertas de mantenimiento

Limpie sólo con un paño húmedo, no utilice disolventes. Proteja sus muebles de contacto con el agua. La infiltración de agua podría arruinar los muebles.

## **NL** Reinigingsnotities

Reinig alleen met een stofdoek of een lichtjes vochtige doek. Gebruik geen schurende poetsmiddelen. Bescherm uw meubelen doorgaans tegen water (bijv. bij het dweilen of als u de bloemen water geeft). De vochtigheid kan in het meubelstuk dringen en het beschadigen

## **PL** Wskazówki dotyczące pielęgnacji

Czyszczenie należy wykonać wyłącznie za pomocą ściereczki lub lekko nawilżonego ręcznika. Nie stosować środków czyszczących do szorowania. Mebel należy chronić przed wodą (np. podczas czyszczenia lub podlewania kwiatków). Wilgoć może wnikać w mebel i uszkodzić go.

## **RU** Обслуживание

Очищайте от пыли тряпкой или слегка влажной ветошью. Не допускается применение чистящих средств, не предназначенных для ухода за мебелью. Предохраняйте мебель от попадания воды (например, при вытирании или поливке цветов). Не допускайте попадания влаги на мебель, чтобы предотвратить ее повреждение.

## **TR** Bakım

Lütfen sadece bir toz bezyle veya hafif nemli yumuşak bir bezle siliniz. Aşındırıcı temizlik malzemeleri kullanmayınız. Genelde mobilyalarınızı sudan koruyunuz (örneğin, yerleri paspaslarken veya çiçekleri sularken). Nem, mobilya parçasına nüfuz edebilir ve zarar verebilir.

## **FR** Conseil d'entretien

Nettoyer avec un plumeau ou un chiffon humide. Ne pas utiliser de dissolvants. En général, garder l'eau loin de vos meubles (par exemple lors de lavages, ou bien pour l'arrosage des plantes). L'humidité peut pénétrer les meubles et les endommager.

## **DE** Pflegehinweise

Bitte nur mit einem Staubtuch oder leicht feuchtem Lappen reinigen. Keine scheuernden Putzmittel verwenden. Schützen Sie Ihre Möbel generell vor Wasser (z.B. beim Wischen oder Blumen gießen). Die Feuchtigkeit kann in das Möbelstück eindringen und es beschädigen.

## **IT** Avvisi di manutenzione

Pulire solamente con un panno umido, non utilizzare solventi. Proteggere i mobili dal contatto con acqua. L'infiltrazione dell'acqua potrebbe rovinare il mobile.

## **RPC** 维护通知

只能用湿布清洁，不要使用溶剂。保护家具不接触水。水渗透可能会破坏家具。

## **SK** Ošetrovanie

Na čistenie používajte len prachovku alebo zľahka navlhčenú utierku. Nepoužívajte žiadne drhúce čistiace prostriedky. Chráňte váš nábytok celkovo pred vodou (napr. pri utieraní alebo polievaní kvetín). Vlhkosť môže vniknúť do nábytku a poškodiť ho.

## **PT** Alertas de manutenção

Limpe apenas com um pano úmido, não use solventes. Proteja sua mobília de contacto com a água. A infiltração de água pode arruinar o mobiliário.