

MIKI

PL Instrukcja montażu

RU Инструкция по монтажу

CZ Návod k montáži

RO Instrucțiuni de montare

D Montageanleitung

SK Návod k montáži

GB Assembly instruction

TR Montaj talimatı

F Model d'emploi

HU Szerelési útmutató

I Istruzione di montaggio

NL Handleiding voor de montage

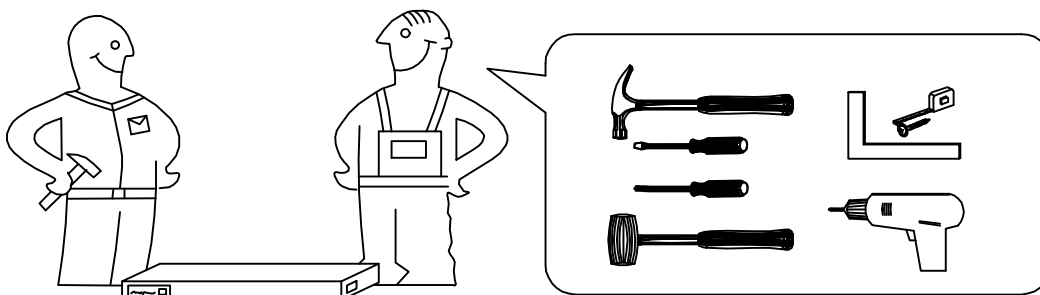

!	Uwaga = Upozornění = Achtung = Attention = Caution = Figyelem Attenzione = Opgelet = Внимание = Atempje = Upozornenie = Dikkat	!
PL	Czyszczenie należy wykonać wyłącznie za pomocą ściereczki lub lekko nawilżonego ręcznika. Nie stosować środków czyszczących do szorowania.	
CZ	Čistení je nutné vykonávať výhradne pomocí utierky alebo ľahko navlhčeného ručníka. Nepoužívajte čistiace prostriedky obsahujúci abrazívni častice.	
D	Bitte nur mit einem Staubtuch oder leicht feuchtem Lappen reinigen. Keine scheuernden Putzmittel verwenden.	
GB	Please only clean with a duster or a damp cloth. Do not use any abrasive cleaners.	
F	Le nettoyage se fait uniquement à l'aide d'un torchon ou d'une serviette légèrement mouillée.	
HU	A tisztítás kizárólag törleruha vagy enyhén nedvesített törölköző segítségével végezhető. Súroló hatású tisztítószereket nem szabad használni.	
I	Pulire esclusivamente con un panno o un asciugamano umido.	
NL	Reinig alleen met een stoffdoek of een lichtjes vochtige doek. Gebruik geen schurende poetsmiddelen.	
RU	Очищайте от пыли тряпкой или слегка влажной ветошью. Не допускается применение чистящих средств, не предназначенных для ухода за мебелью.	
RO	Curățarea trebuie efectuată numai cu o cârpă sau cu un prosop ușor umezit. Nu utilizați agenți de curățare abrazivi.	
SK	Čistení je nutné vykonávať výhradne pomocí utierky alebo ľahko zvlhnutým ručníkom. Nepoužívajte čistiace prostriedky obsahujúci abrazívni častice.	
TR	Lütfen sadece bir toz beziyile veya hafif nemli yumuşak bir bezle siliniz. Aşındırıcı temizlik malzemeleri kullanmayınız.	

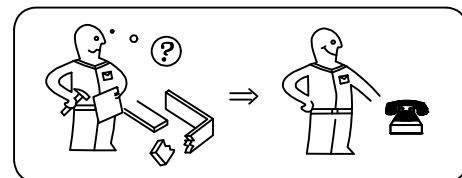
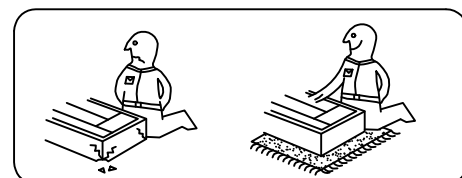

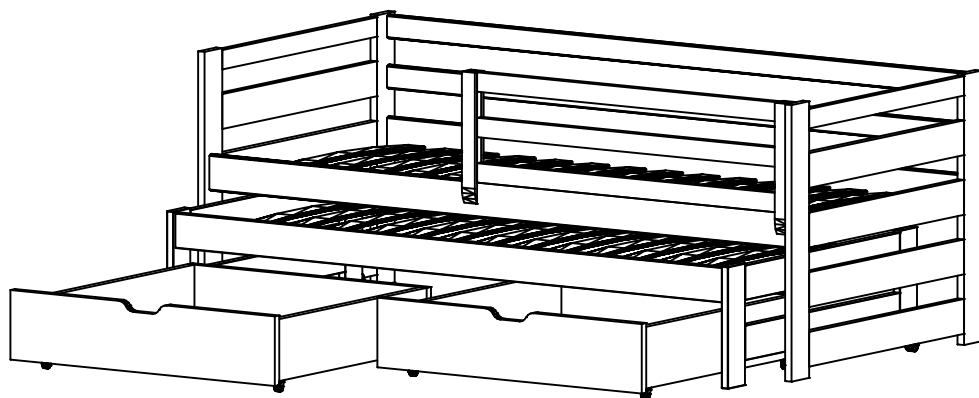

Nie wyrzucaj opakowań, dopóki nie sprawdzisz, że masz wszystkie części i okucia.



Do not discard any of the packaging until you have checked that you have all the parts and the pack of fittings.

Parts Checklist

- 1.** Zagłówek - 2 sztuki
Headboard - 2 pcs.
- 2.** Listwa pod stelaż - 2 sztuk
Side Rail (front) - 2 pcs.
- 3.** Listwa zabezpieczająca długa - 2 sztuki
Long Guardrail - 2 pcs.
- 4.** Barieka zabezpieczająca - 1 sztuk
Safety barrier - 1 pcs.
- 5.** Prząd szuflady - 2 sztuki
Front of drawers - 2 pcs.
- 6.** Tył szuflady - 2 sztuki
Rear of drawers - 2 pcs.
- 7.** Bok szuflady - 4 sztuki
Side for drawers - 4 pcs.
- 8.** Spód szuflady - 2 sztuk
Bottom for drawers - 2 pcs.
- 9.** Stelaż FLEX - 2 komplety
Rack boards (Flex) - 2x SET
- 10.** Zagłówek łóżka wysuwanego - 2 sztuki
Headrest for trundle bed - 2 pcs.
- 11.** Listwa do części wysuwanej - 2 sztuki
Side Rail for trundle bed - 2 pcs.

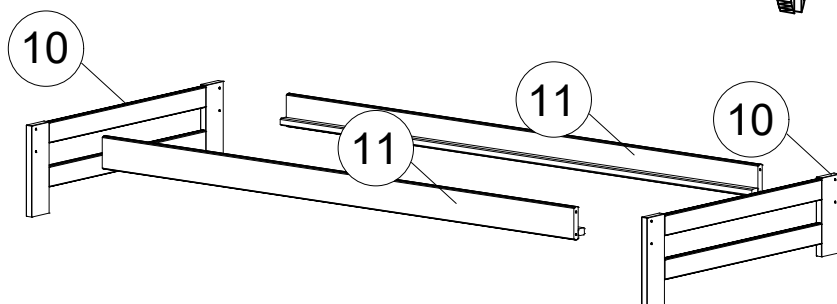
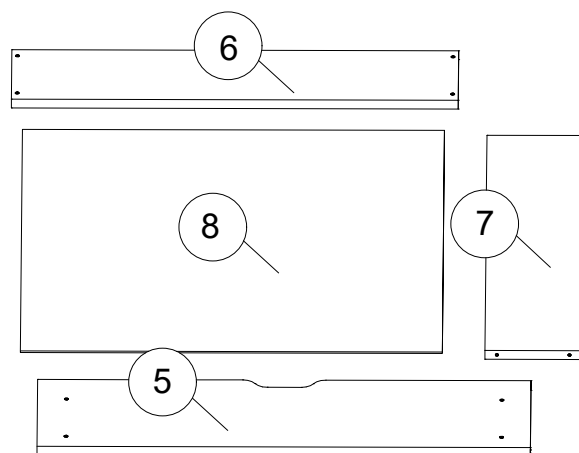
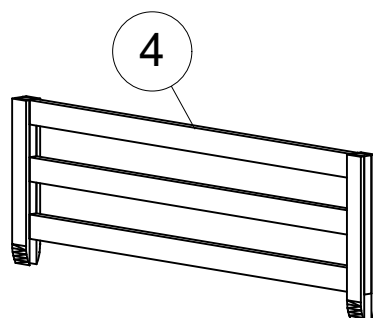
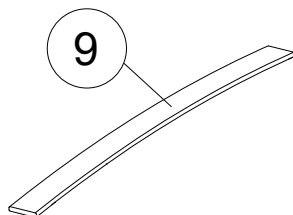
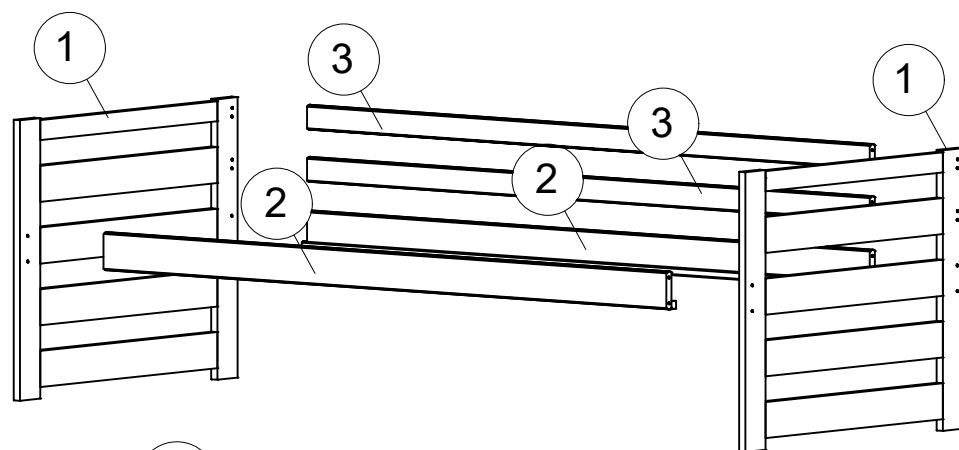

1 Fittings Checklist

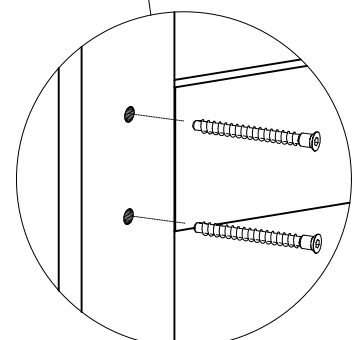
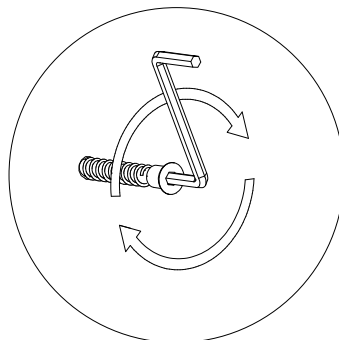
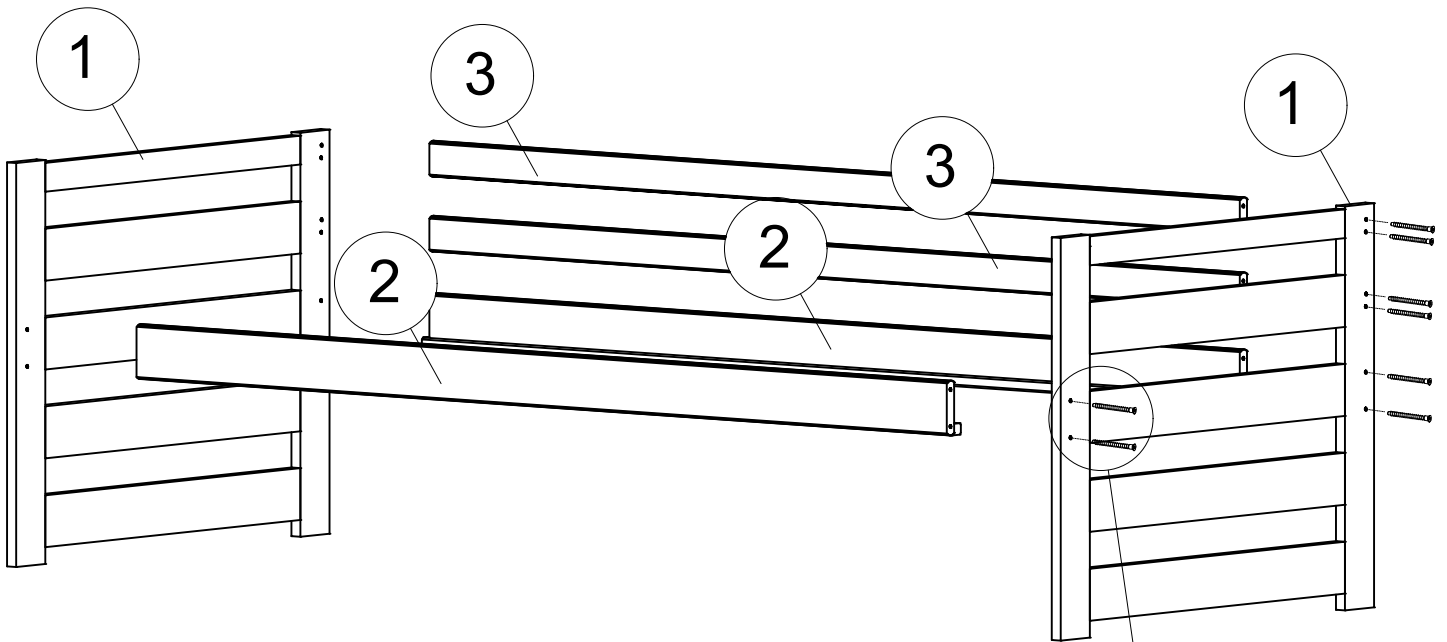
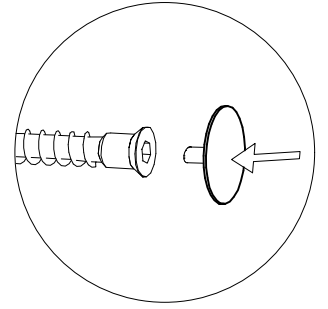
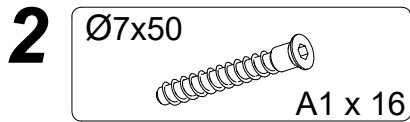
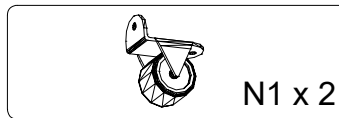
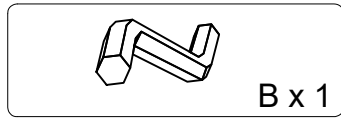
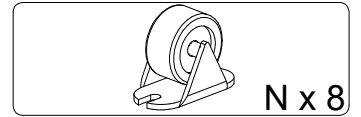
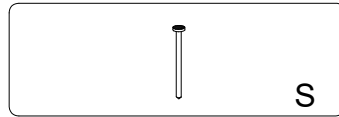
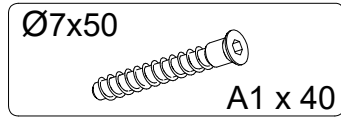
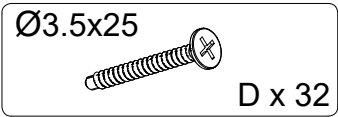

3 Ø3.5x25
D x 6

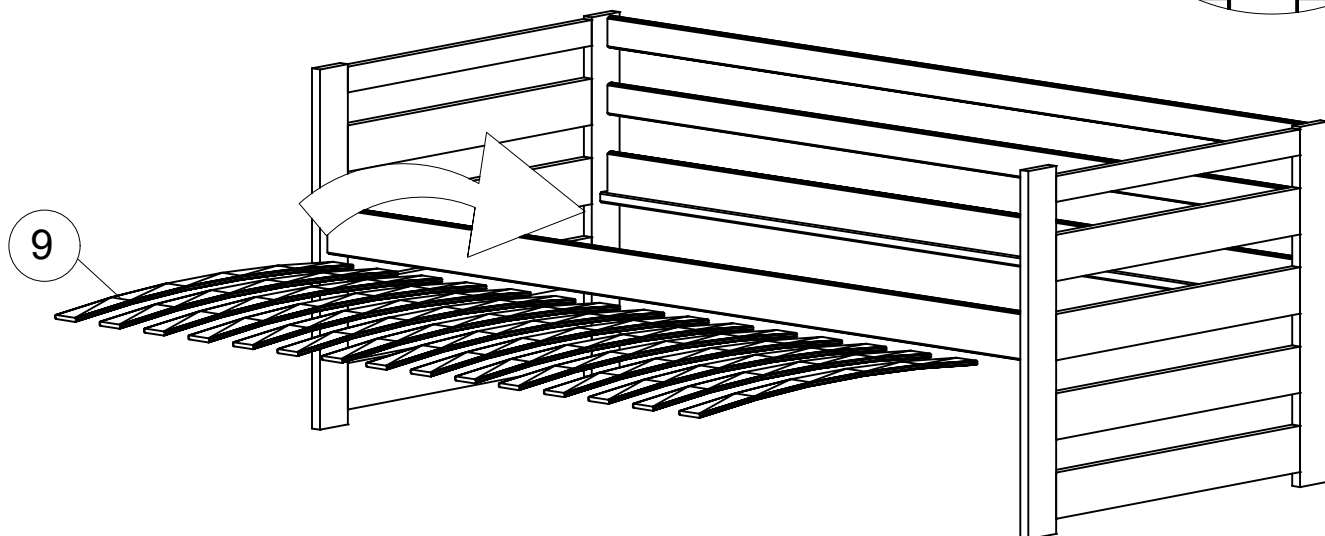
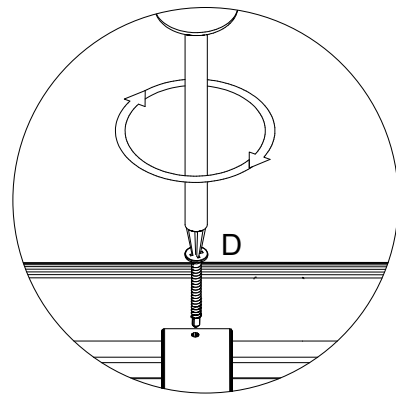

4

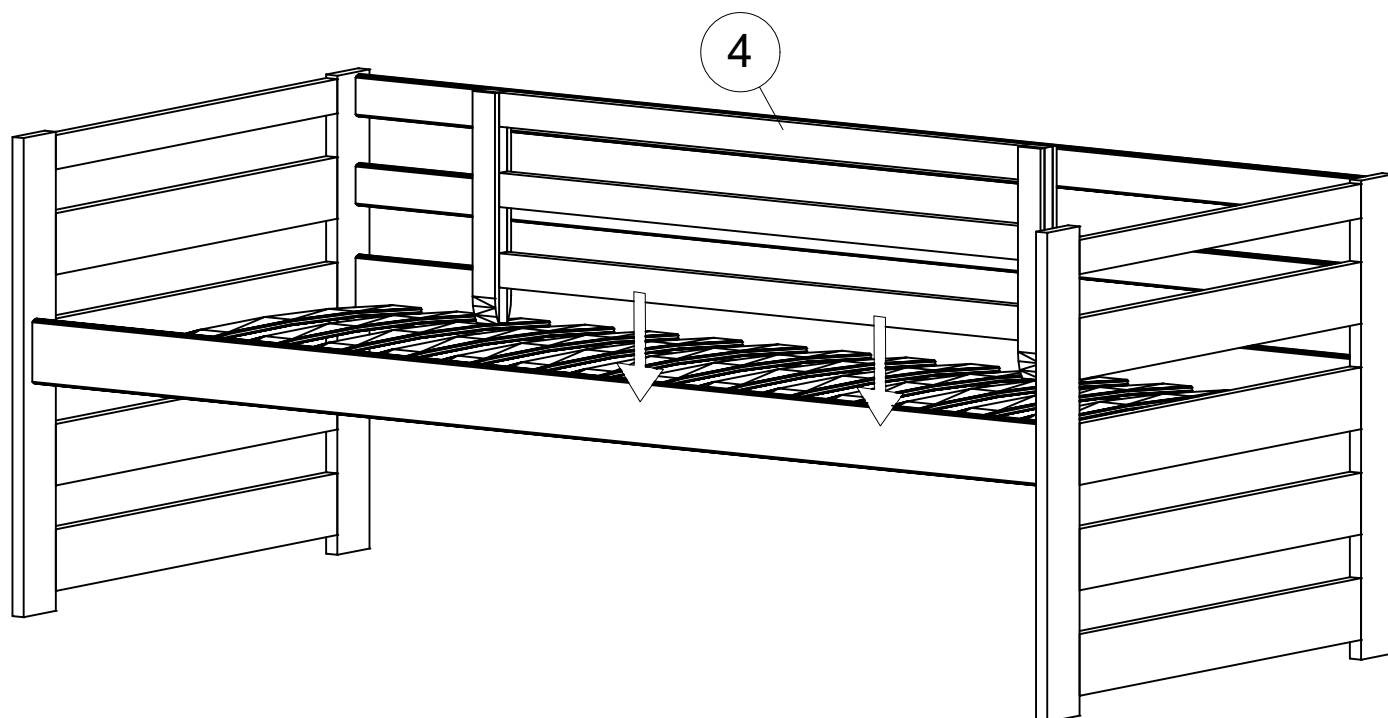

5 Ø7x50
A1 x 4

X2

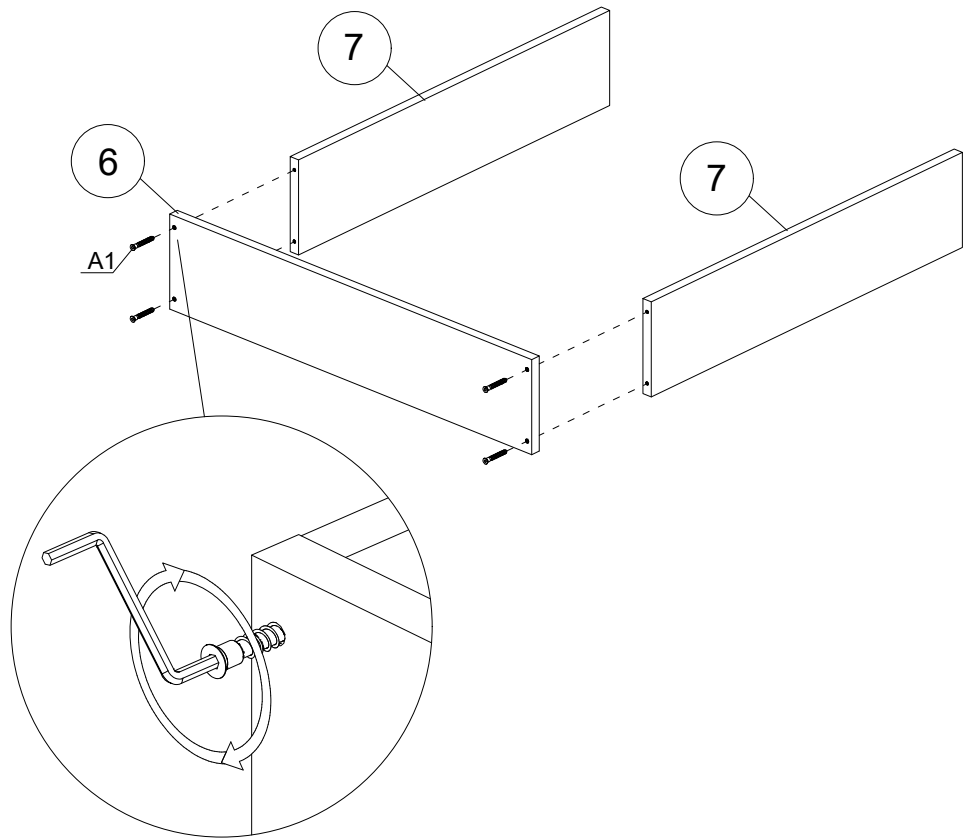

6 Ø7x50
A1 x 4

X2

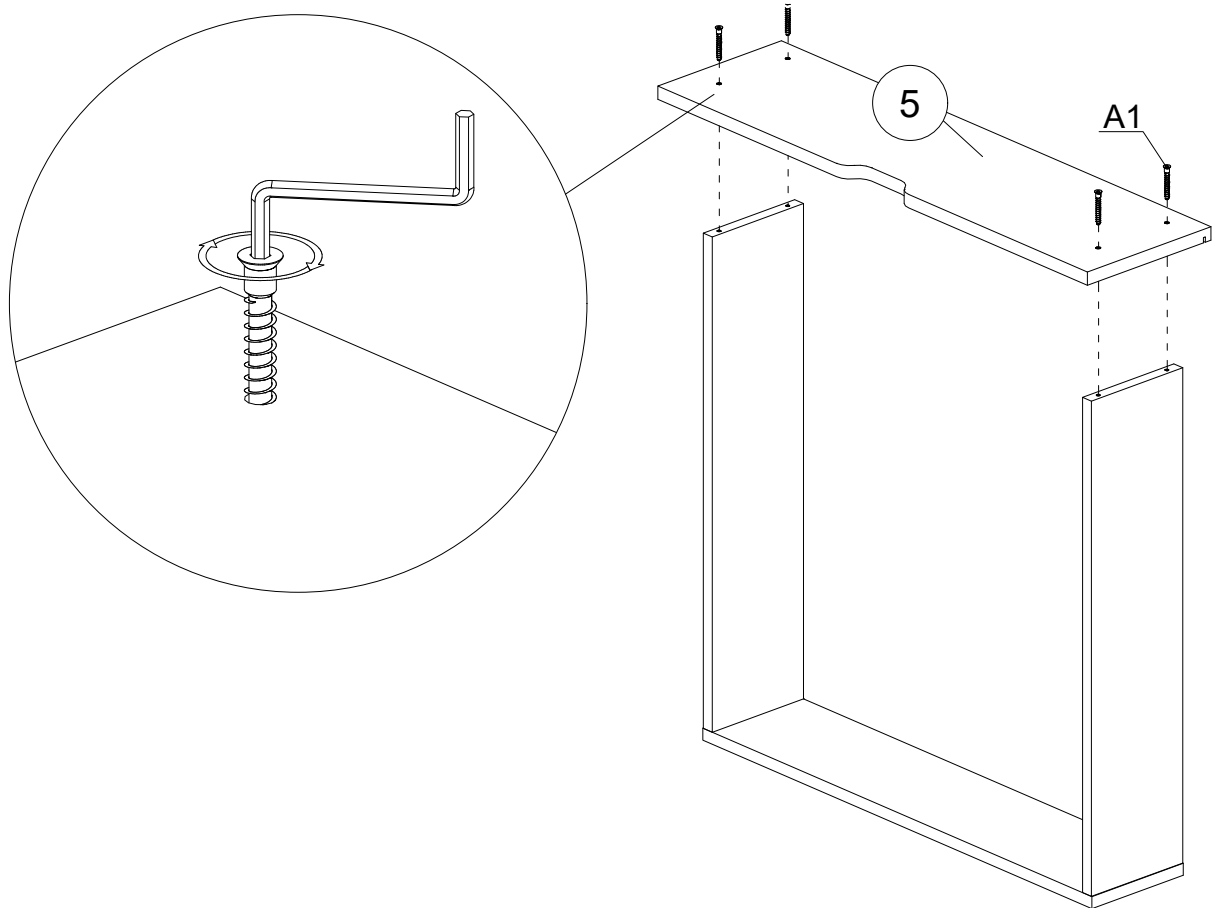

7

Ø4x20

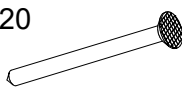

S1

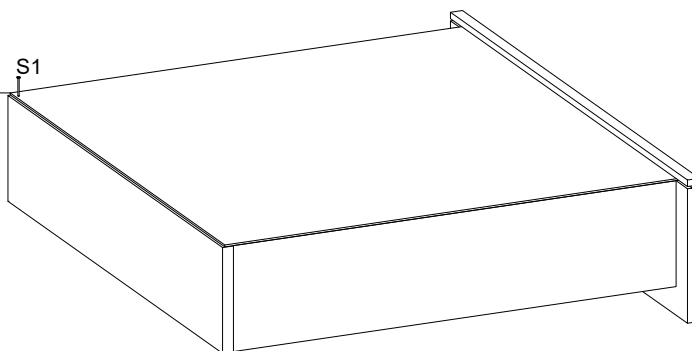
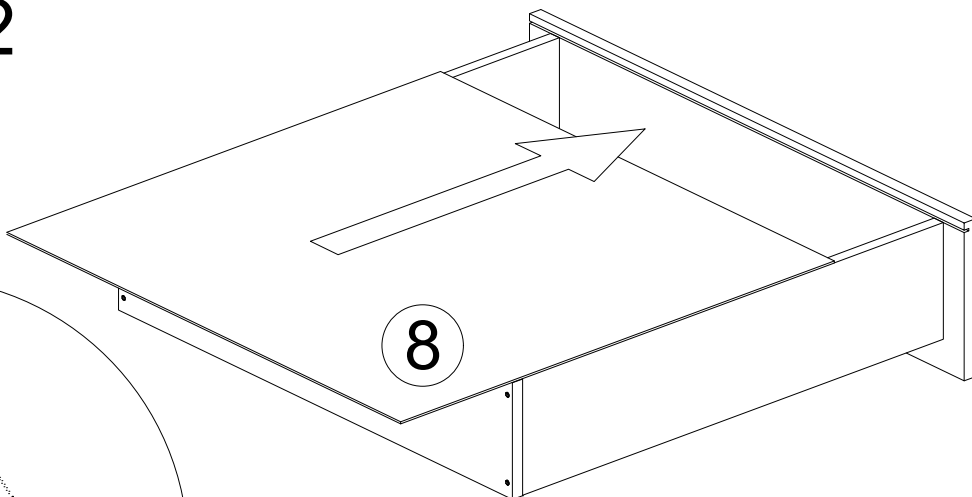
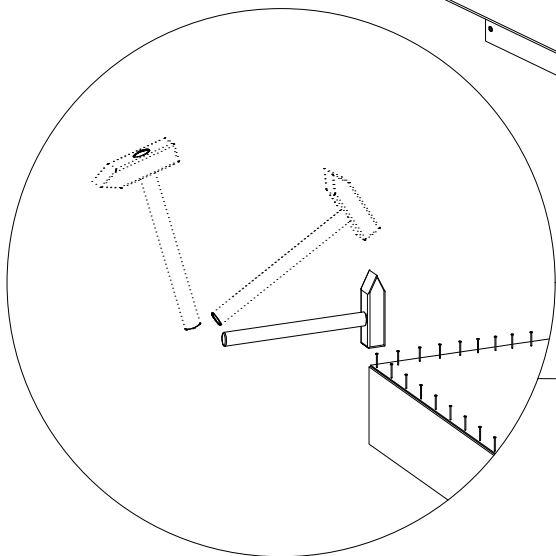
X2**8**

Ø3.5x25



D x 8

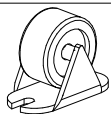

N x 4

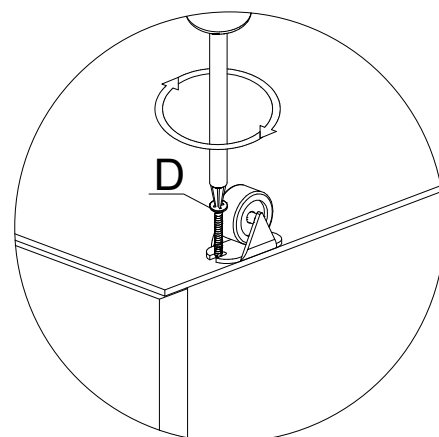
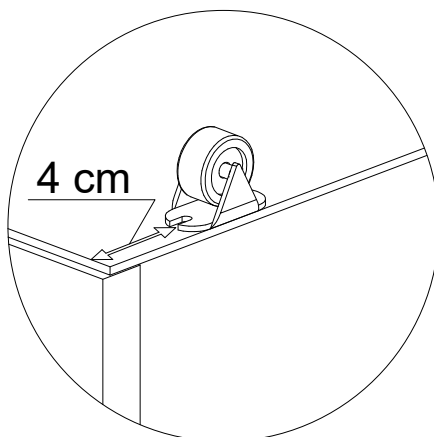
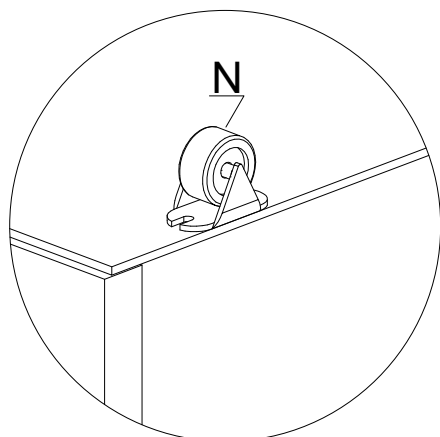
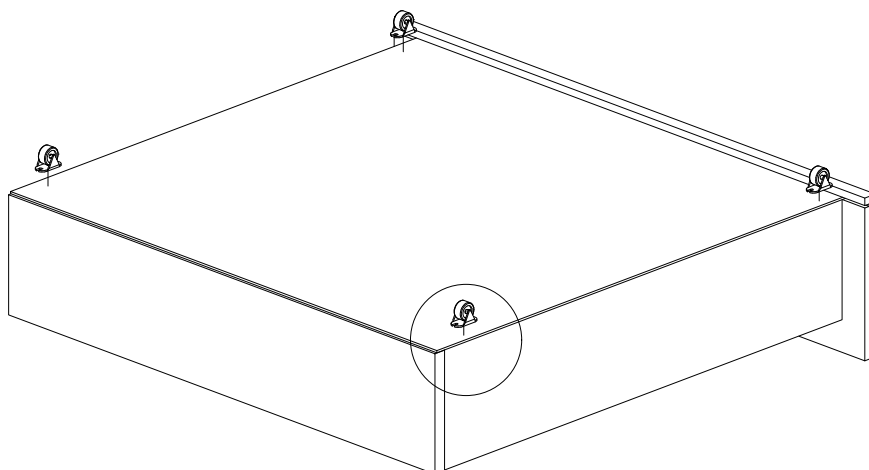
X2

9



N1 x 2

Ø3.5x25



D x 4

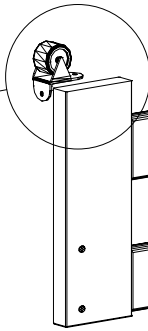
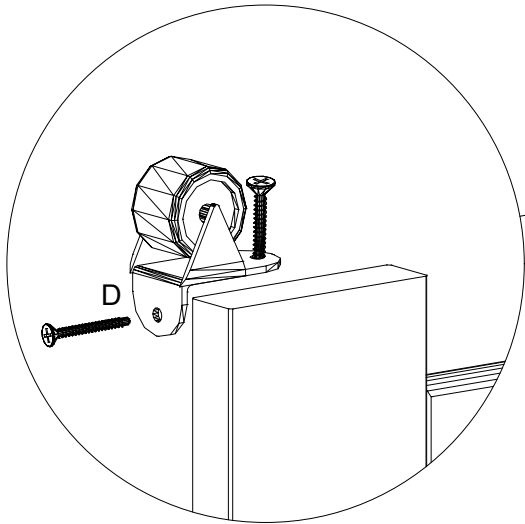
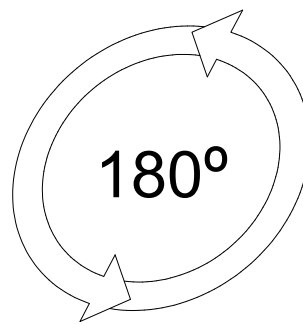

11



10

Ø7x50

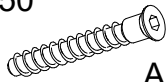

A1 x 8

B x 8

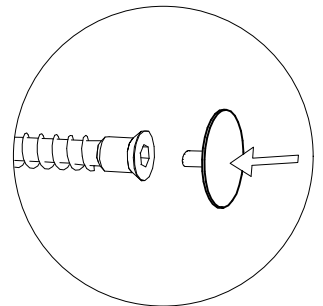

10

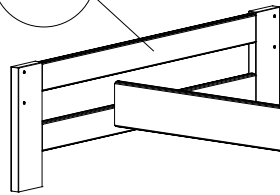

11

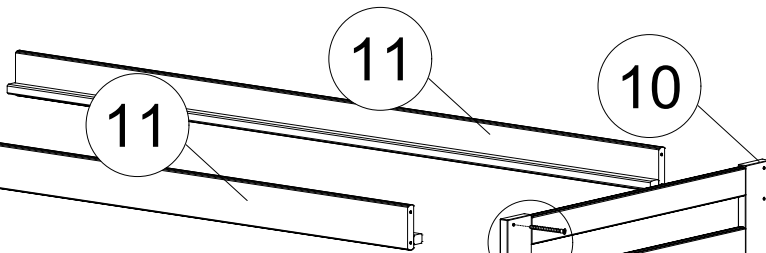

10

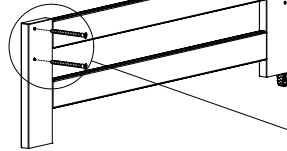

A1

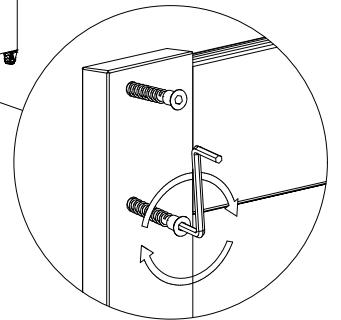

11

9

