

Safety Information



Sit in the center of the chair, with your back to the backrest



Do not sit at the front edge of the chair



Do not stand on the chair



Do not use the chair with more than one person



Do not push the chair around when a person is sitting in it



Do not push down on the backrest when a person is reclined

- EN** Thank you for choosing this product. We strive to provide you with the best quality products and service in the industry. Should you have any issues, please don't hesitate to contact us.
- DE** Vielen Dank, dass Sie sich für dieses Produkt entschieden haben. Wir bemühen uns, Ihnen die besten Qualitätsprodukte und den besten Service in der Branche zu bieten. Wenn Sie Probleme haben, zögern Sie bitte nicht, uns zu kontaktieren.
- FR** Merci d'avoir choisi ce produit. Nous nous efforçons de vous fournir les meilleurs produits et services de qualité de l'industrie. Si vous rencontrez des problèmes, n'hésitez pas à nous contacter.

DUMOS®

User Manual

Benutzerhandbuch
Manuel d'utilisation

C-1190-4P
C-1190-1P

Ergonomic Design



Installation video







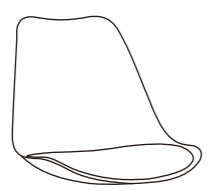
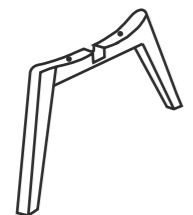
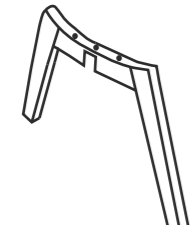

Assembly Instructions

Montageanleitung

Instructions d'assemblage

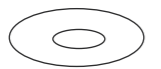
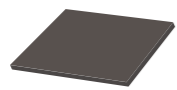

Part		Qty.
A		1
B		1
C		1
D		1
E		4
F		1
G		5
H		4
I		5

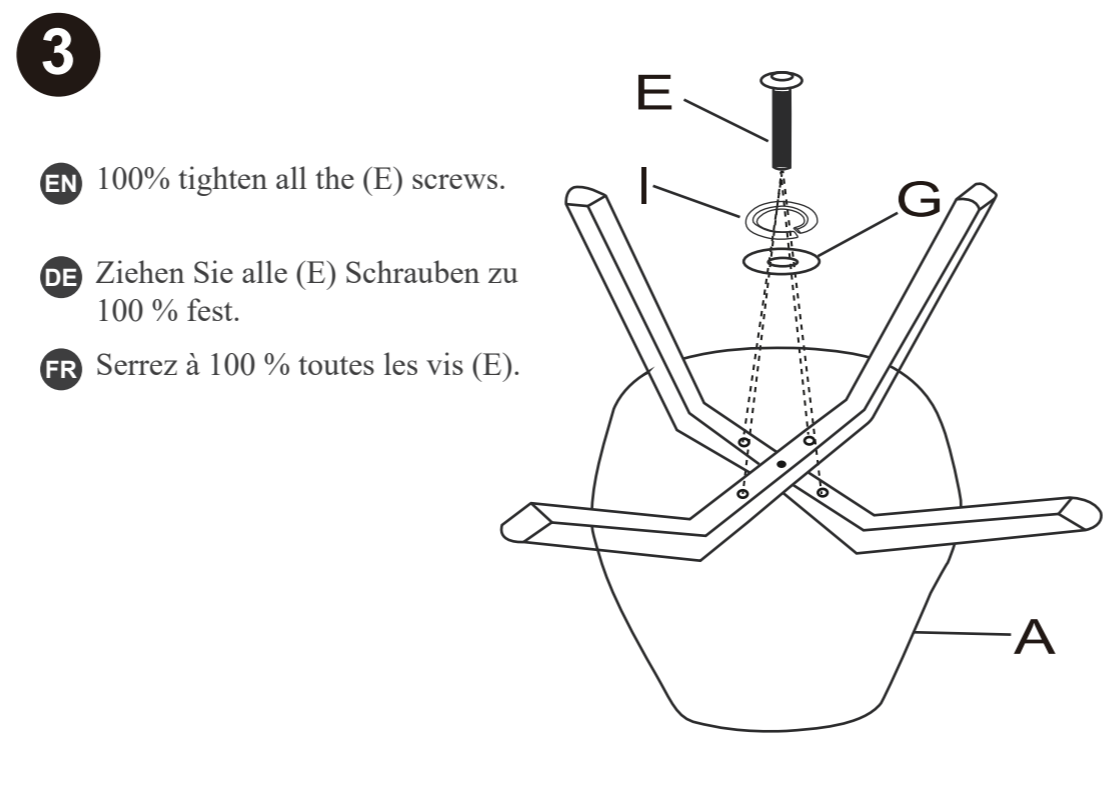
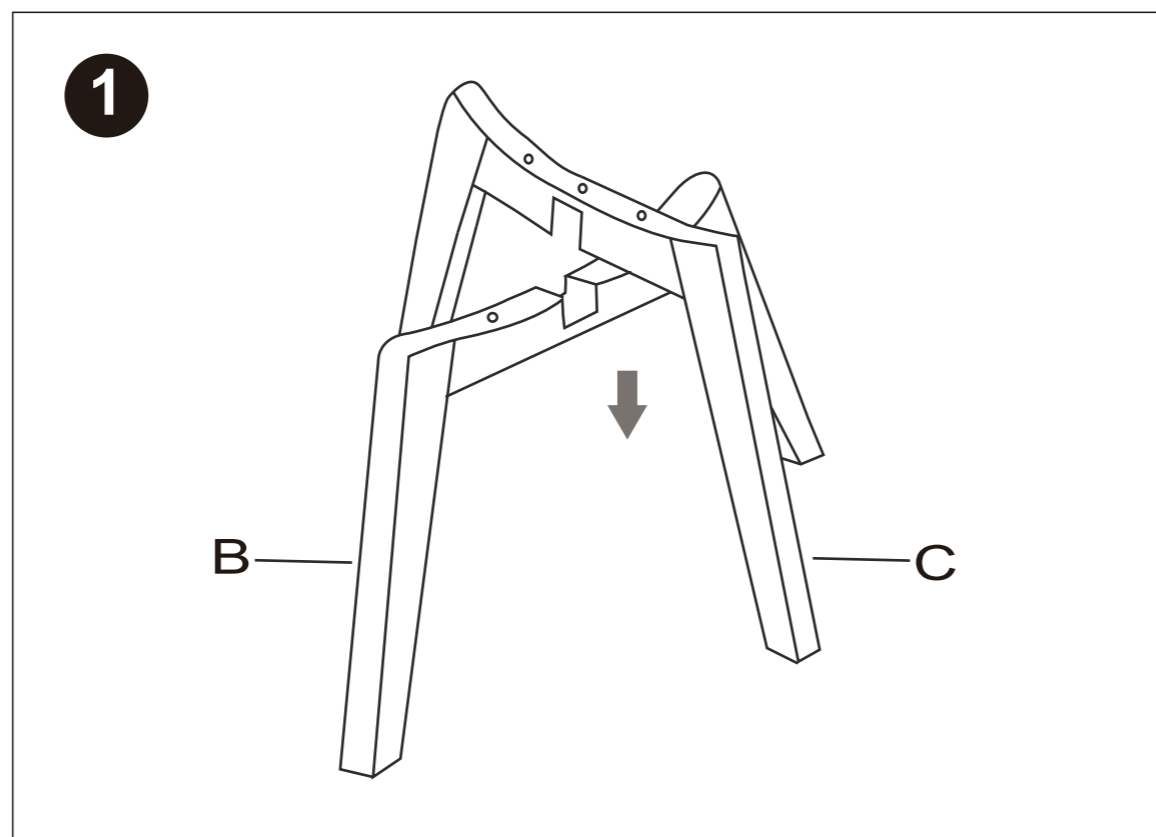

- 3**
- EN** 100% tighten all the (E) screws.
 - DE** Ziehen Sie alle (E) Schrauben zu 100 % fest.
 - FR** Serrez à 100 % toutes les vis (E).

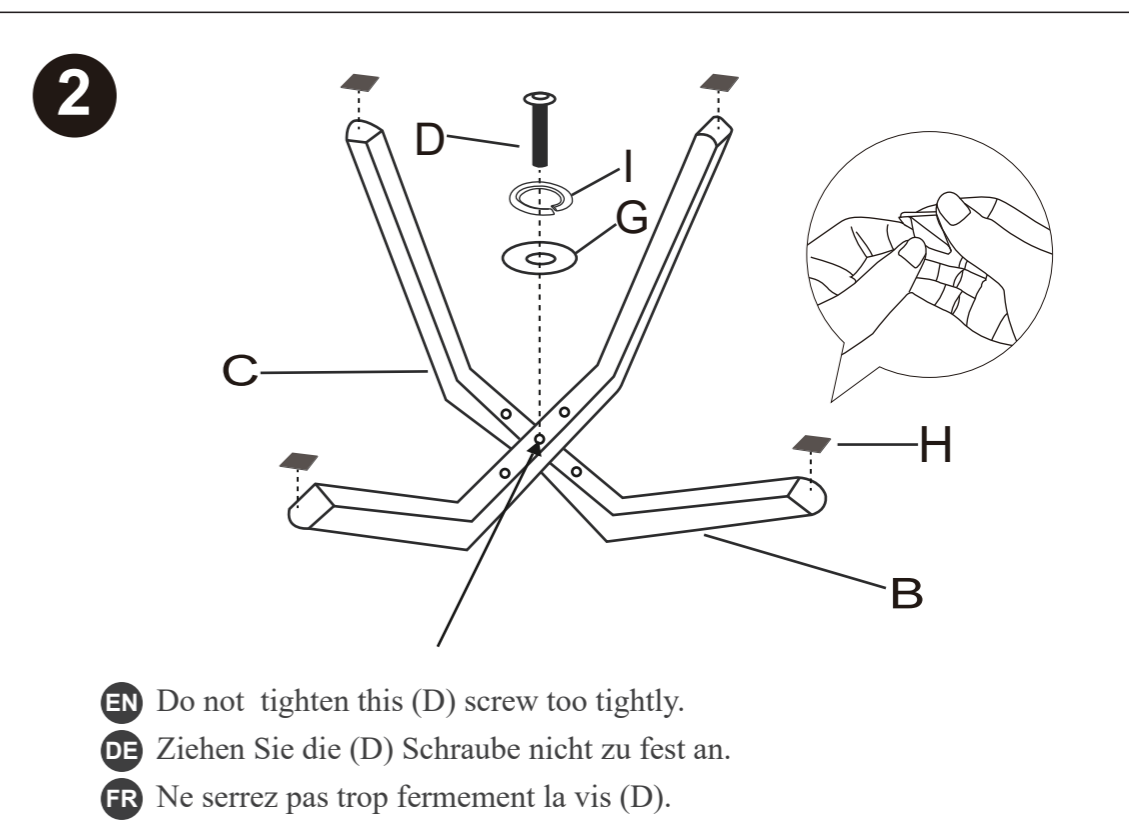

- 2**
- EN** Do not tighten this (D) screw too tightly.
 - DE** Ziehen Sie die (D) Schraube nicht zu fest an.
 - FR** Ne serrez pas trop fermement la vis (D).

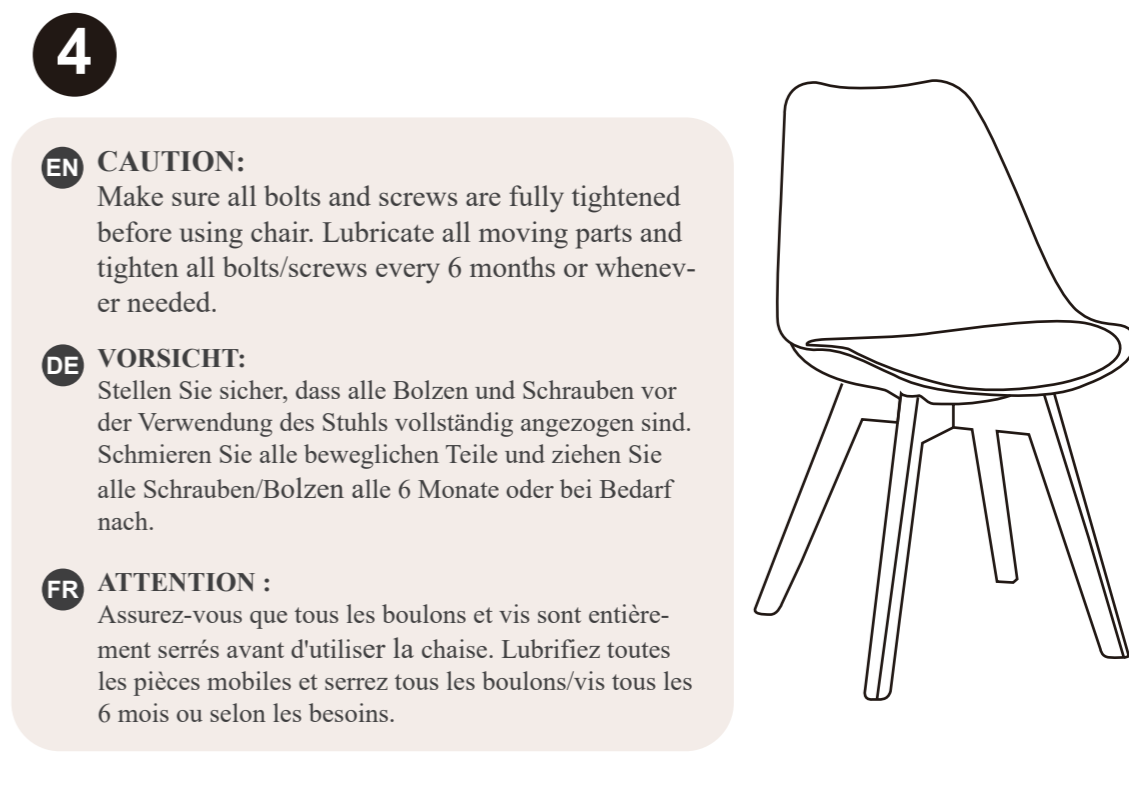

- 4**
- EN CAUTION:** Make sure all bolts and screws are fully tightened before using chair. Lubricate all moving parts and tighten all bolts/screws every 6 months or whenever needed.
 - DE VORSICHT:** Stellen Sie sicher, dass alle Bolzen und Schrauben vor der Verwendung des Stuhls vollständig angezogen sind. Schmieren Sie alle beweglichen Teile und ziehen Sie alle Schrauben/Bolzen alle 6 Monate oder bei Bedarf nach.
 - FR ATTENTION :** Assurez-vous que tous les boulons et vis sont entièrement serrés avant d'utiliser la chaise. Lubrifiez toutes les pièces mobiles et serrez tous les boulons/vis tous les 6 mois ou selon les besoins.

