

JASHEN

WET & DRY VACUUM CLEANER

USER GUIDE F16 SERIES

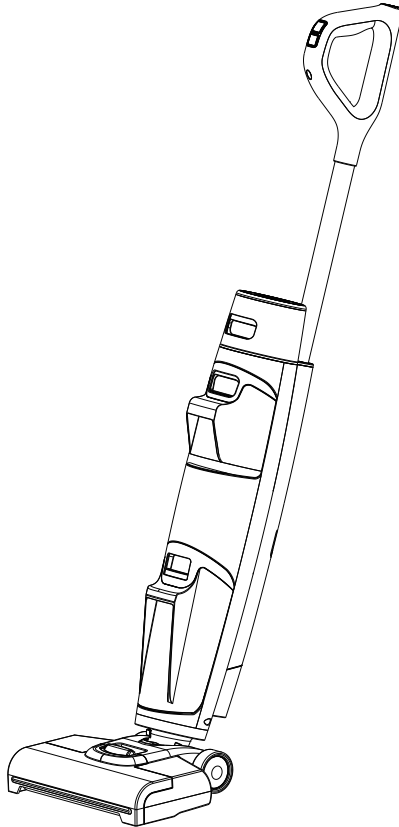

Go online for a comprehensive walk through of your new purchase!

This guide features everything you need to get ready for first use, including setting up, using and maintaining your machine, but join us online for a comprehensive walk through. Our online support includes tips and troubleshooting, videos, product registration, parts and more. Visit **www.jashen.com**.

CONTENTS

Important Safety Instructions	4-5
Product View.....	6-7
Assembly / Disassemble.....	8
Charging the Battery.....	8
Filling the Clean Water Tank.....	9
Cleaning Your Floors.....	10
Emptying the Dirty Water Tank.....	10
Cleaning Your Filter & Floater.....	11
Brush Roller Self-cleaning.....	12
Replace the Battery.....	12
Cleaning the Brush Roller Cover.....	13
Cleaning the Brush Roller.....	13
Storing Your Machine.....	14
Specifications.....	14
Troubleshooting.....	15

IMPORTANT SAFETY INSTRUCTIONS

READ ALL INSTRUCTIONS BEFORE USING YOUR APPLIANCE.

When using an electrical appliance, basic precautions should be observed, including the following:



TO REDUCE THE RISK OF FIRE, ELECTRIC SHOCK, OR INJURY:

- Use indoor hard floors only.
- Do not allow it to be used as a toy. Close attention is necessary when used by or near children.
- Do not use for any purpose other than described in this user guide. Use only the manufacturer's recommended attachments.
- Do not charge with a damaged cord or plug.
- Do not unplug by pulling on the Docking Station cord. Instead, to unplug, grasp the charger, not the cord.
- Do not handle Docking Station, charging plug, or appliance with wet hands.
- Do not put any object into openings. Do not use any opening blocked; keep openings free of dust, lint, hair, and anything that may reduce airflow.
- Keep hair, loose clothing, fingers, and all body parts away from openings and moving parts of the appliance and its accessories.
- Use extra care when cleaning on stairs.
- Do not use to pick up flammable or combustible materials (lighter fluid, gasoline, kerosene, etc.) or use in areas where they may be present.
- Do not use the appliance in an enclosed space filled with vapors given off by oil-based paint, paint thinner, some moth-proofing substances, flammable dust, or other explosive or toxic vapors.
- Do not pick up toxic material (chlorine bleach, ammonia, drain cleaner, etc.).
- Do not pick up anything burning or smoking, such as cigarettes, matches, or hot ashes.
- Do not pick up hard or sharp objects such as glass, nails, screws, coins, etc.
- Use only JASHEN® cleaning products intended for use with this appliance to prevent internal component damage. See the Cleaning Formulas section of this guide.
- Do not carry the appliance while in use.
- Do not immerse. Use only on surfaces moistened by the cleaning process.
- Plastic film can be dangerous. To avoid the danger of suffocation, keep away from babies and children.
- Always connect to a proper electrical socket.
- Keep cord away from heated surfaces.
- Do not use without filters in place.
- Do not charge the unit outdoors.
- Do not incinerate the appliance even if it is severely damaged. The batteries can explode in a fire.
- Use only with charger SIL, Model CQ30B-300100-Au.
- Recharge appliance only with the charger specified by the manufacturer. A charger suitable for one type of battery pack may create risk of injury and fire when used with another battery pack.
- When the battery pack is not in use, keep it away from other metal objects, like paper clips, coins, keys, nails, screws, or other small metal objects, that can make a connection from one terminal to another. Shorting the battery terminals together may cause burns or a fire.
- Do not immerse in water or liquid.
- Do not use a battery pack or appliance that is damaged or modified. Damaged or modified batteries may exhibit unpredictable behavior resulting in fire, explosion, or risk of injury.
- Do not expose a battery pack or appliance to fire or excessive temperature. Exposure to fire or temperature above 265°F may cause an explosion.
- Follow all charging instructions and do not charge the battery pack or appliance outside the temperature range of 40-104°F. Charging improperly or at temperatures outside this range may damage the battery and increase the risk of fire.
- Prevent unintentional starting. Ensure the switch is OFF before connecting to the battery pack, picking up or carrying the appliance. You are holding the machine with your finger on the switch or energizing an appliance that has the switch on invites accidents.
- Under abusive conditions, liquid may be ejected from the battery; avoid contact. If contact accidentally occurs, flush with water. If liquid contacts eyes, additionally seek medical help. Liquid ejected from the battery may cause irritation or burns.
- If the appliance is not working as it should, has been dropped, damaged, left outdoors, or dropped into water, return it to a service center.
- Have servicing performed by a qualified repair person using only identical replacement parts. This will ensure that the safety of the product is maintained.
- Do not turn ON your appliance until you are familiar with all instructions and operating procedures.
- Risk of injury from moving parts. The brush may start unexpectedly. Turn OFF before cleaning or servicing.
- If the appliance is not working as it should, has been dropped, damaged, left outdoors, or dropped into water, return it to a service center.
- Have servicing performed by a qualified repair person using only identical replacement parts. This will ensure that the safety of the product is maintained.
- Unplug the charger from the electrical socket when not used before cleaning, maintaining, or servicing the appliance.
- The liquid must not be directed towards equipment containing electrical components.
- Use only the type and amount of liquids specified under the operations section of this guide.
- Use only on surface moistened by the cleaning process.
- Do not pull or carry the charger by a cord; use the cord as a handle, close the door on the cord, or pull the cord around sharp edges or corners.

- The battery pack and charger base output terminals are not to be short-circuited.
- Do not modify or attempt to repair the appliance except as indicated in the instructions for use and care.
- The battery must be removed from the appliance before it is scrapped.

IMPORTANT INFORMATION

- Keep appliance on a level surface.
- If your appliance has a motorized Brush Roll, do not leave the machine running in the same spot without the fully upright handle.
- Do not store where freezing may occur.
- This product contains a wireless device. Refer to the website for regulatory information.

SAVE THESE INSTRUCTIONS

This model is for household use only. Commercial use of this unit voids the manufacturer's warranty.

FCC/IC NOTICE: This equipment has been tested and found to comply with the limits for a Class B digital device, according to part 15 of the FCC Rules. These limits are designed to provide reasonable protection against harmful interference in a residential installation. This equipment generates, uses, and can radiate radio frequency energy and, if not installed and used following the instructions, may cause harmful interference to radio communications. However, there is no guarantee that interference will not occur in a particular installation. Suppose this equipment does cause harmful interference to radio or television reception, which can be determined by turning the equipment off and on. In that case, the user is encouraged to correct the interference by one or more of the following measures:
 (1) Reorient or relocate the receiving antenna.

(2) Increase the separation between the equipment and receiver. (3) Connect the equipment into an outlet on a circuit different from that to which the receiver is connected. (4) Consult the dealer or an experienced radio/TV technician for help. This device complies with Part 15 of FCC Rules and Industry Canada license-exempt RSS standard(s). Operation is subject to the following two conditions: (1) this device may not cause harmful interference, and (2) this device must accept any interference, including interference that may cause undesired operation of the device. Le présent appareil est conforme aux la partie 15 des règles de la FCC et CNR d'Industrie Canada applicables aux appareils radio exempts de licence. L'exploitation est autorisée aux deux conditions suivantes : (1) l'appareil ne doit pas produire de brouillage, et (2) l'utilisateur de l'appareil doit accepter tout brouillage radioélectrique subi, même si le brouillage est susceptible d'en compromettre le fonctionnement. Privacy of communications may not be ensured when using this device.

WARNING: Changes or modifications to this equipment not expressly approved by the party responsible for compliance could void the user's authority to operate the equipment.

CAUTION: The Digital Display houses the transmitter and must be kept at a separation distance of at least 20 cm from all persons.

ATTENTION: L'écran à affichage numérique contient l'émetteur. Gardez-le à une distance d'un minimum de 20 cm de toute personne.

RANGE OF USAGE

- Use indoor hard floors only, such as vinyl, tile, sealed wood, etc. Use on a rough surface may not get the best performance.
- Keep your appliance away from heat sources, such as a fireplace or heater, to avoid causing deformation.

- Do not use to pick up flammable or combustible materials (lighter fluid, gasoline, kerosene, etc.) or use in areas where they may be present.

ABOUT FLOOR FORMULA

- A large amount of floor formula entering into the motor may cause damage to the appliance.
- Add floor formula as instructed in the product operation section. We recommend using the provided floor formula. Do not use the product with an acidic, alkaline floor formula or any substances harmful to the environment.
- Keep out of reach of children. If any solution gets into the eyes, immediately flush them with clean water. If any solution is swallowed by accident, seek medical care immediately.
- Dirty water and floor formula disposal should comply with local environmental regulations.







ABOUT THE APPLIANCE

- Do not modify or attempt to repair the appliance except as indicated in the instructions for operating and cleaning.
- Charge the appliance with the Jashen adaptor. Input Voltage: AC 100-240V. Both high and low voltages can damage the adaptor, appliance or even cause danger to the user.
- Use extra care when cleaning on stairs.
- Ensure that the Power Switch is in the OFF position before picking up or carrying the appliance. Do not lay flat or lean the appliance to prevent dirty water from entering into the motor.
- To avoid being tripped accidentally, please put away the appliance on the charging base.
- Always install the Dirty Water Tank and Clean Water Tank properly before use.
- Do not allow the appliance or charger to get wet to avoid the risk of fire or injury caused by a short circuit.

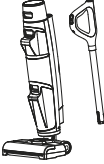
WARRANTY

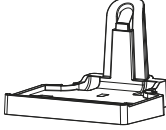
2-Year limited warranty, may vary by area. Visit **www.jashen.com** contact us at **support@jashen-europe.eu** (Europe Area) or **support@jashen.com** (America Area) for complete warranty information.

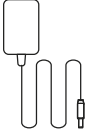
What's in the Box?

 <p>Handle & Body</p>	 <p>Brush Roller</p>	 <p>Docking Station</p>	 <p>Hepa</p>
 <p>Adaptor</p>	 <p>Access Holder</p>	 <p>Cleaning Tool</p>	

NOTE: Standard accessories may vary by model.

Product View

Product View

- A: Self-cleaning Button
- B: Mode Button
- C: Power Button
- D: Digital Display
- E: Clean Water Tank Release Button
- F: Clean Water Tank Handle
- G: Dirty Water Tank Release Button
- H: Dirty Water Tank Handle
- I: Brush Roller Cover Release Button
- J: Brush Roller Window
- K: Brush Roller
- L: Dirty Water Tank (DWT)
- M: Floater
- N: Clean Water Tank (CWT)
- O: Battery Release Button
- P: Tube

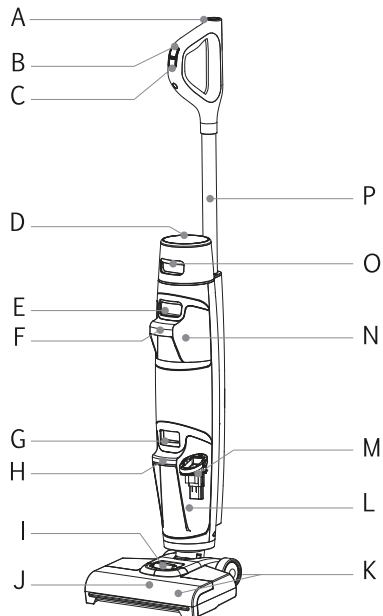

Digital Display

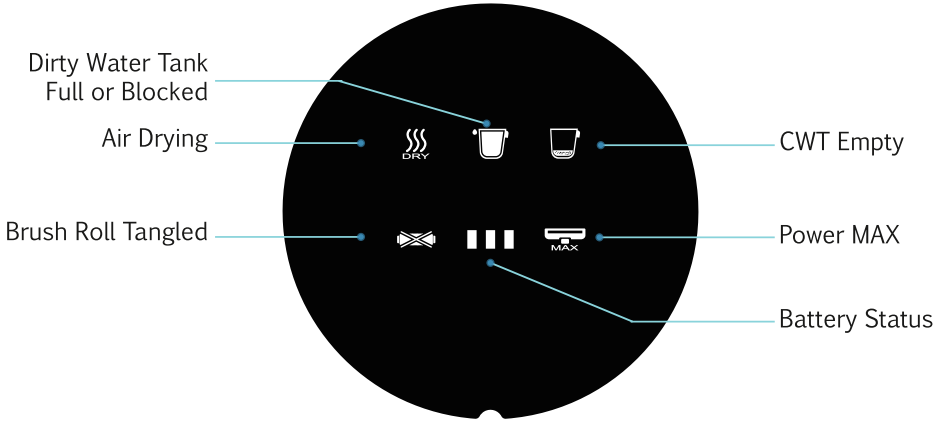



Indicator

When in Use	Means
	Full power
	Medium power
	Low power
	Low power, please charge.
	Off: no power or battery malfunction.
	Indicator blinking: CWT is empty.
	Indicator blinking: DWT is full or channel has a blockage.
	Indicator blinking: brush roller has a blockage.
	Appliance is in self-drying.
	During Charging

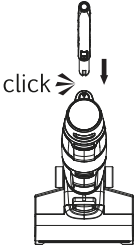
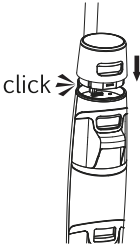
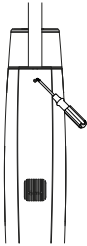
Assembly / Disassemble

ASSEMBLY		DISASSEMBLE
		
<p>1. Insert handle into body of machine until you hear a “click”.</p>	<p>2. Insert battery into body of machine until you hear a “click”.</p>	<p>3. Press spring with a tool (like a screwdriver) and lift handle from the appliance at the same time.</p>

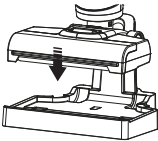
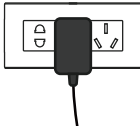

Charging the Battery

		
<p>1. Place your F16 onto the Docking Station to charge.</p>	<p>2. Plug the adapter into a suitable wall outlet. The Battery Life Indicator will illuminate when charging.</p>	<p>3. For a maximum run time, charge the machine for 3.5hours.</p>

⚠️ WARNING

- Only charge the appliance with the adaptor supplied by Jashen.
- To avoid tripping hazards, please place the appliance on the charging base near a wall during charging.
- During long periods of not being used, the appliance must be charged once every 3 months for optimal performance. It may take 3±0.5 hours for a full charge.
- Store indoors in a dry place. Do not expose the appliance to sunlight or freezing temperatures.
Recommended temperature range: 39.2°F~104°F.

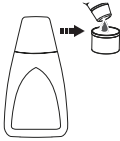
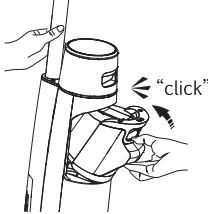

Filling the Clean Water Tank

		
<p>1. Press the CWT release button to remove the CWT from the appliance.</p>	<p>2. Open the tank cap</p>	<p>3. Fill with tap water to the Max line.</p>
		
<p>4. When deep cleaning is necessary, add one bottle cap of the floor formula to the CWT and tightly close the cap.</p>	<p>5. Place the tank back into the appliance. You should hear a “Click” if done correctly.</p>	

WARNING

- To reduce the risk of fire and electric shock due to internal component damage, use only JASHEN cleaning formula intended for use with the hard floor device.
- Only use water under 140F°. **DO NOT USE HOT WATER.**

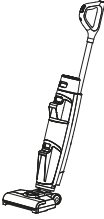

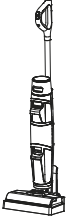
Cleaning Your Floors

		
<p>1. Recline the machine.</p>	<p>2. Turn the machine ON by pressing the Power Button to start the Brush Roll spinning. Next, press the Mode Button to switch between the Standard mode and Max Mode.</p>	<p>3. Turn OFF the machine by pressing the Power button (ⓘ). Place the appliance on the charging base vertically after use for recharge and storage.</p>

ATTENTION:

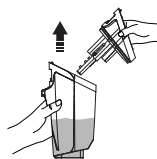

- Do not vacuum foamed liquid.
- The cordless hard floor cleaner is to be used on indoor hard floors only, such as vinyl, tile, sealed wood, etc. Use on a rough surface may not get the best performance.
- To vacuum water left on the surface, the appliance will switch off in 3 seconds after power off.

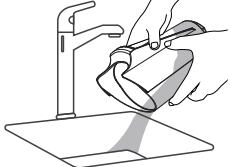
Emptying the Dirty Water Tank

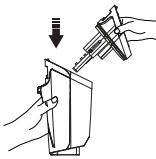
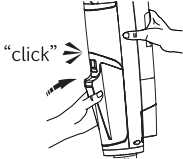
			
<p>1. Press the Dirty Water Tank (DWT) release button to remove the DWT from the appliance.</p>	<p>2. Pull up the tank lid.</p>	<p>3. Separate the hair and debris from the dirty water by grasping the strainer tab and pulling up. Throw the debris into the trash.</p>	<p>4. Pour the dirty water into the sink and rinse the Dirty Water Tank.</p>

			
<p>5. Reassemble the garbage separator to the Dirty Water Tank.</p>	<p>6. Reassemble the tank lid.</p>	<p>7. Place the DWT back into the appliance.</p>	

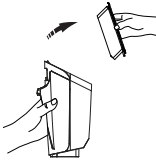
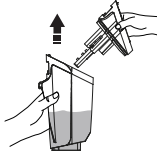
Clean Your Floater

		
<p>1. Grasp recessed area on each side of the HEPA and pull upward.</p>	<p>2. Pull up the tank lid.</p>	<p>3. Rinse the Floater with water.</p>

ATTENTION

Please remove HEPA and then clean the Dirty Water Tank, otherwise, wet HEPA will cause the suction to drop and water will come out on both sides of the Dirty Water Tank.

Brush Roller Self-cleaning

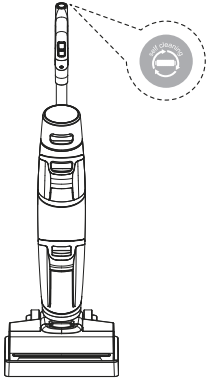

1. Place the machine on the Docking Station after use. When self-cleaning icon is blinking, press the self-cleaning Button to start the process.
2. Once the cycle is complete, the appliance will begin charging. Empty and clean the Dirty Water Tank after the cycle is completed.

Note:

- Ensure the charging dock is plugged in.
- Before the cycle, please clean the DWT and ensure the water level in the CWT exceeds 40%.

Replace the Battery



Note:

- To reduce the risk of electrical shock, turn Power Button OFF before performing maintenance or troubleshooting checks.
- For optimal performance and to prevent odors, always clean and dry DWT, floater, filters, brush roller cover completely after each use.
- Please make sure each part is installed correctly or the appliance may not work properly.
- After maintenance, place the appliance on the charging base vertically. Do not expose the appliance to direct sunlight, and store it indoors at dry place.

Cleaning the Brush Roller Cover

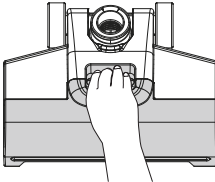
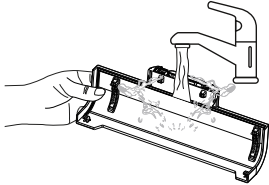
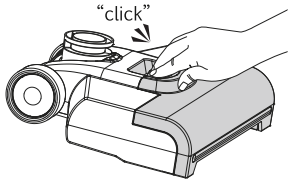
		
<p>1. Grab the front handle while pressing the button and pull upward to remove it.</p>	<p>2. Rinse with water.</p>	<p>3. When replacing, always latch the brush cover into place to avoid leakage.</p>

Cleaning the Brush Roller

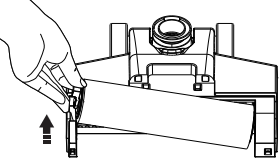
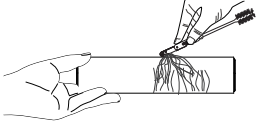
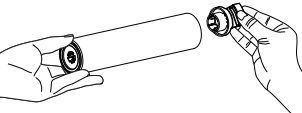
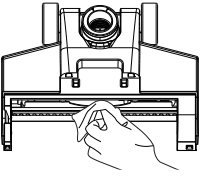
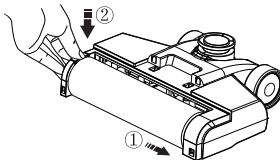
		
<p>Remove the brush roller by grabbing the brush roller tab and pulling upward.</p>	<p>Using the cleaning tool, remove the hair and debris wrapped around the roller.</p>	<p>Remove hair and debris from the brush roller chamber.</p>
		
<p>Remove hair and debris from the opening with a tissue or a damp cloth.</p>	<p>Inserting the brush roller end into the right side of the holder, then lock the pull tab into place by pressing downward.</p>	

Storing Your Machine

Store F16 in a protected, dry area. Since this product uses water, it must not be stored where there is danger of freezing. Freezing will damage internal components and may void the warranty.

WARNING

To reduce the risk of fire, electric shock or injury, turn power OFF and disconnect plug from electrical outlet before performing maintenance or troubleshooting on the dock.







NOTICE

To reduce the risk of a leaking condition, do not store machine where freezing may occur. Damage to internal components may result.

Specifications

Product	F16
Adapter Input	100-240V~50/60Hz
Output	30.5V 1.0A
Rated Voltage	25.9V 
Rated Power	220W
Running Time	ECO: 30mins, Max: 20mins
Charging Time	3±0.5 hrs
CWT Capacity	0.8L
DWT Capacity	0.5L
Waterproof	IPX4

Troubleshooting

Problem	Possible cause	Solution
The appliance does not turn on.	Out of power. Auto protection for overheating.	Charge the appliance. Restart after cooling down.
Weak suction.	Debris channel is blocked. The HEPA is dirty or not installed.	Clean the debris channel and DWT. Clean and dry the HEPA.
Brush roller tangled indicator blinking. 	The brush roller is blocked.	Remove blockages.
CWT empty indicator blinking. 	CWT is empty.	Refill CWT.
DWT full indicator blinking. 	The dirty water in DWT has reached the MAX line.	Empty the dirty water and then reinstall the DWT.
All lights off in operation. 	Battery overheat or malfunction.	Cool the appliance down and restart.
Battery indicator blinking. 	Low battery.	Charge the appliance, or restart.
MAX icon blinking. 	Motor malfunction.	Contact Customer Service.

Note:

If the above troubleshooting guide fails to provide a solution, please contact us at support@jashen-europe.eu (Europe Area) or support@jashen.com (America Area) or visit our website www.jashen.com for further support.

JASHEN



[JashenCleaning](#)



MAIL US: support@jashen.com
EU: support@jashen-europe.eu



TEL US: + **49 209 5130 7777** (Toll-free for EU-wide)
Monday-Friday from 10 A.M. to 6 P.M CET
EU: + **1-877-402-9868** (Toll free for North America)
Monday-Friday from 9:00 A.M - 5:00 P.M CST

If you purchase products outside of the above areas, please contact your local seller.

But wait, there's more!

Join us online for a comprehensive walk through of your new product, including troubleshooting, product registration, parts and more.

Visit www.jashen.com



REGISTER



INFO



VIDEOS



PARTS



SUPPORT