



EKIPA

0094NOTIC6100



BUFFET

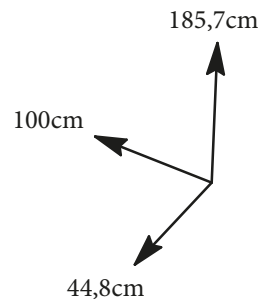

FR Remerciements :
Nous vous remercions d'avoir choisi un meuble créé et fabriqué par Ekipa et espérons qu'il vous donnera entière satisfaction.

EN Thanks :
Thank you for choosing furniture designed and manufactured by Ekipa. We hope you are totally satisfied your purchase.

ES Agradecimientos :
Les damos las gracias por haber elegido un mueble diseñado y fabricado por el Ekipa y esperamos que sea de su total agrado.

DE Danksagung:
Wir danken Ihnen für den Kauf eines Frankreich von der Ekipa entworfenen und hergestellten Möbelstücks und hoffen, dass Sie es zu Ihrer vollkommnen Zufriedenheit finden werden.



Temps de montage : 2h00



contact@parisot.com



Conseils de préparation au montage : 45 min

video conseil
<https://qrco.de/bcJeNz>

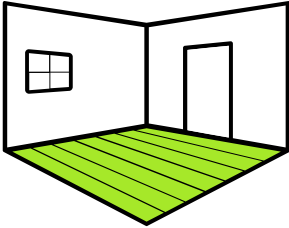

Faire un peu de place

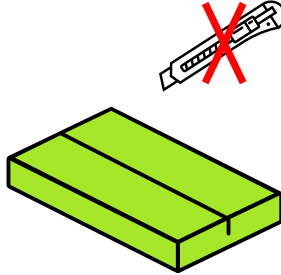

Pas d'outils tranchants

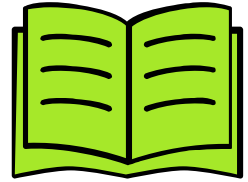

Bien suivre les instructions de la notice de montage

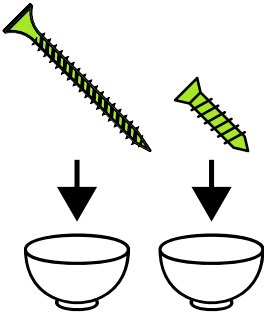

Trier vos quincailleries

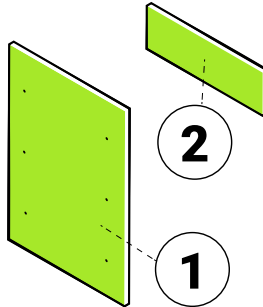

Repérer vos pièces

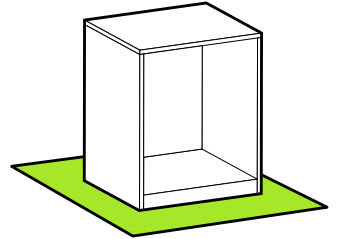

Protéger votre sol

Matériel nécessaire

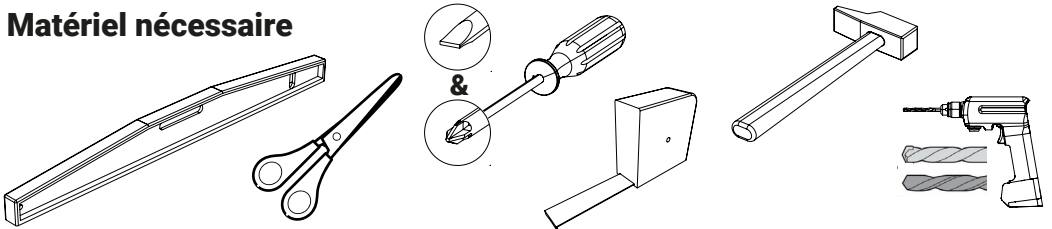

Conseils d'entretien

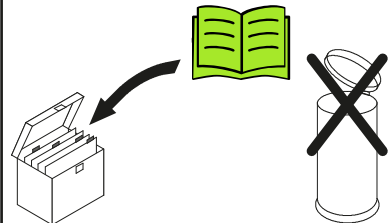



Numéroter vos pièces ci-dessous à l'aide de «Post-it» non fournis.

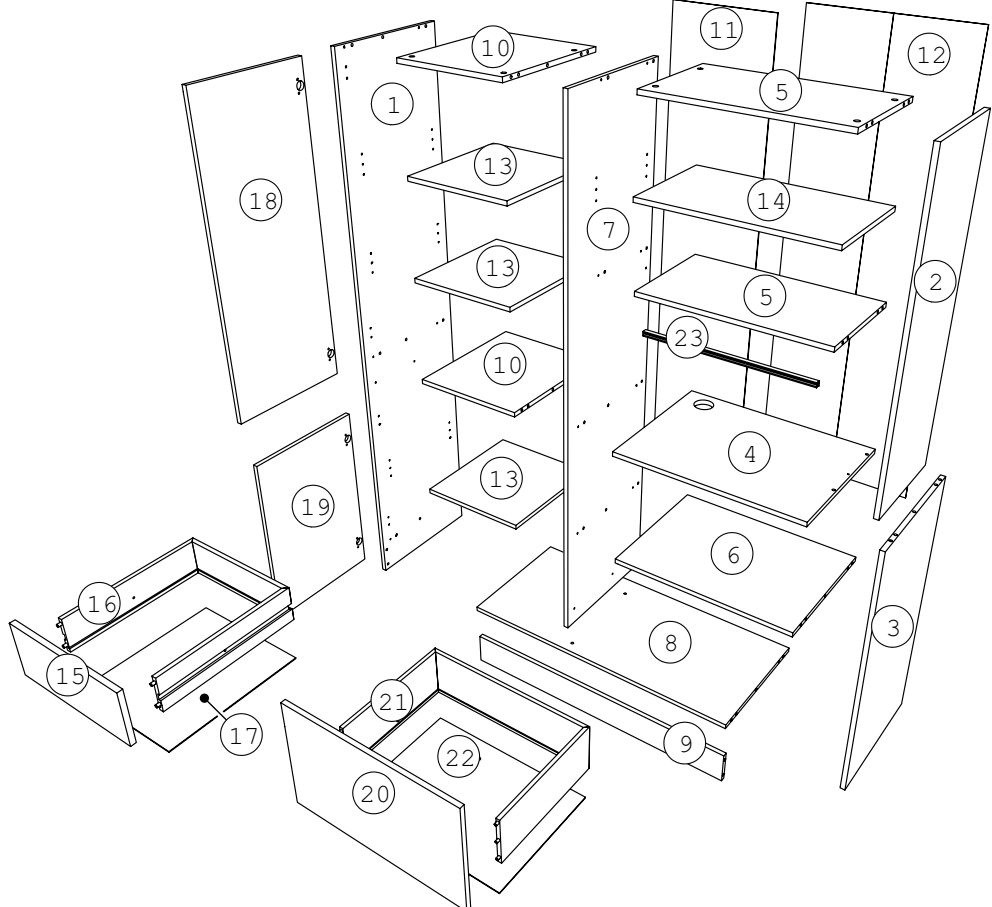



Rep	Qté	cm			Rep	Qté	cm		
01	1	185,3	43	1,5	12	1	174	60,8	0,25
02	1	99,25	33	1,5	13	3	36,7	40	1,5
03	1	84,55	43	1,5	14	1	58,6	32,9	1,5
04	1	60,25	44,5	1,5	15	1	39,5	15,6	1,5
05	2	58,7	32,9	1,5	16	1	114,9	10	1,25
06	1	58,7	42,85	1,5	17	1	39,4	34,5	0,25
07	1	172,85	42,9	1,5	18	1	98,8	39,5	1,5
08	1	97	42,95	1,5	19	1	58,8	39,5	1,5
09	1	97	10,8	1,5	20	1	59,7	36,4	1,5
10	2	36,8	42,85	1,5	21	1	136,2	16,0	1,25
11	1	174	38,9	0,25	22	1	54,8	39,9	0,25
					23	1	58,2	1,7	1,6

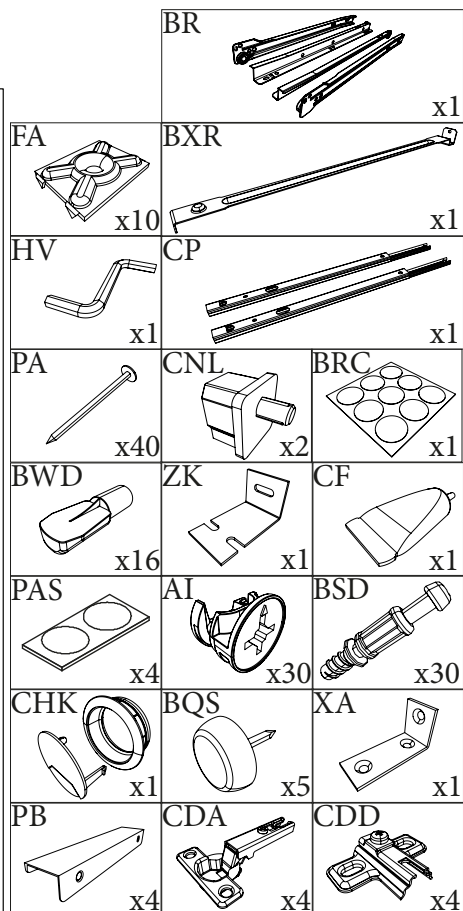
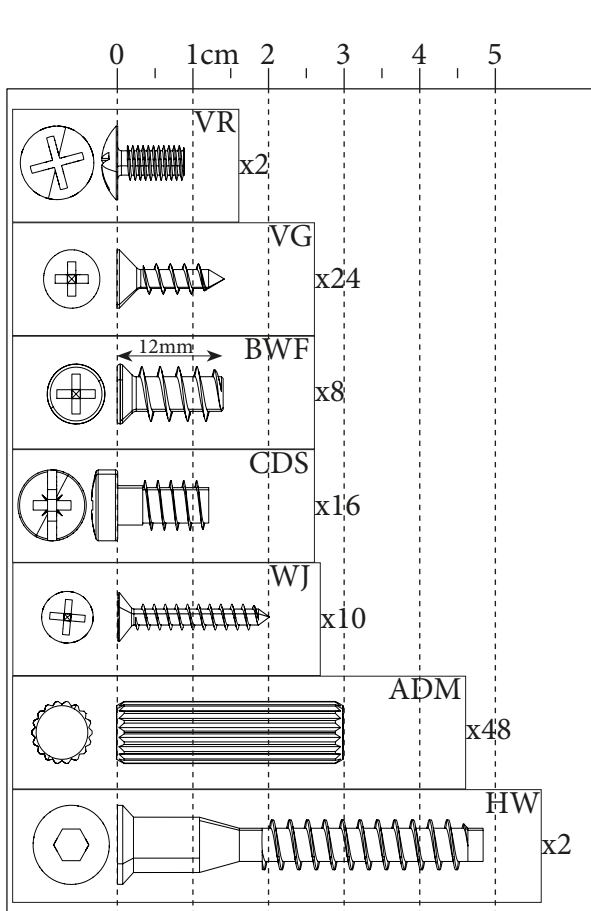

FR- Nous vous conseillons d'organiser les quincailleries en séparant chaque référence.

EN- We advise you to organize the hardware stores by separating each reference.



1 ADM BSD
  
 x10 x4

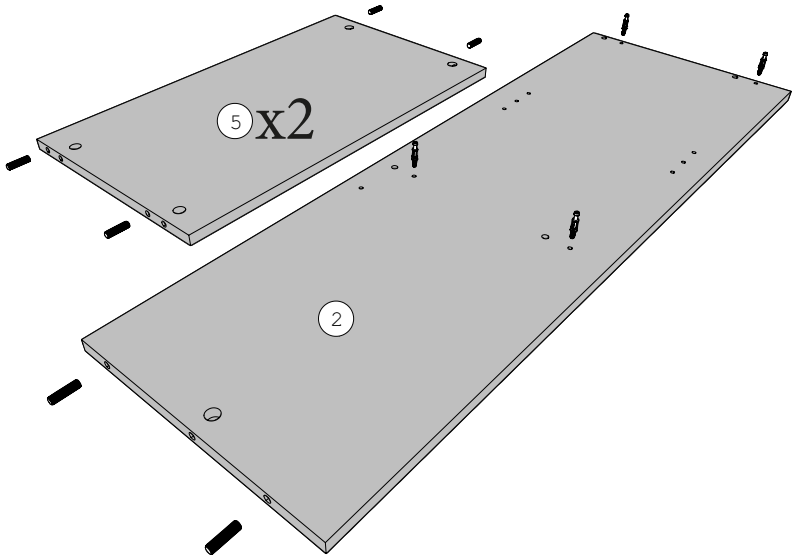
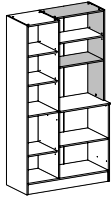

2 AI

 x4

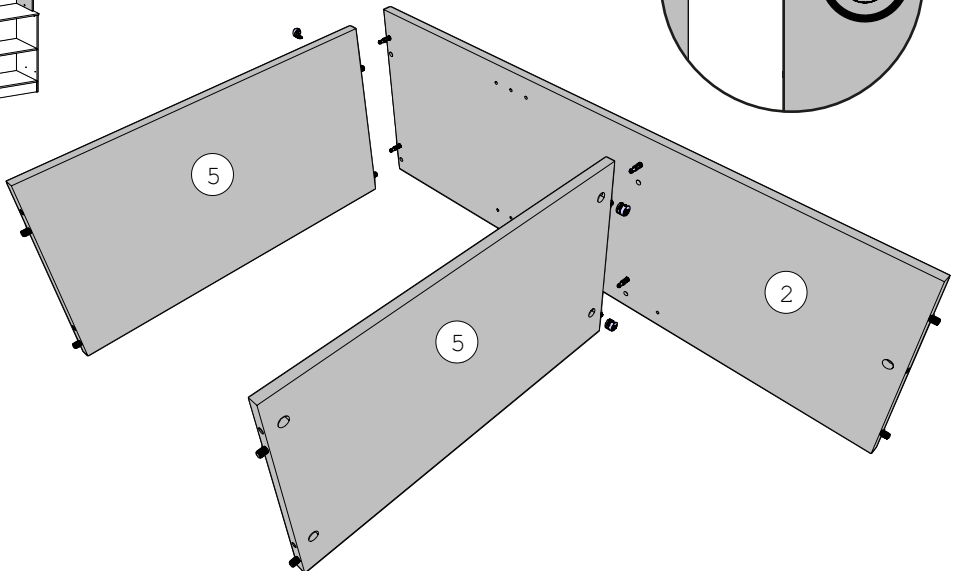
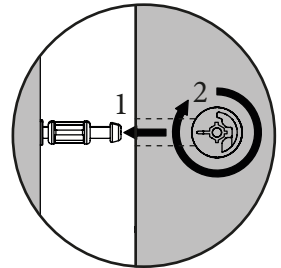
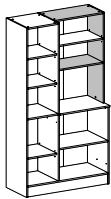

3 BSD ADM
x1 x3

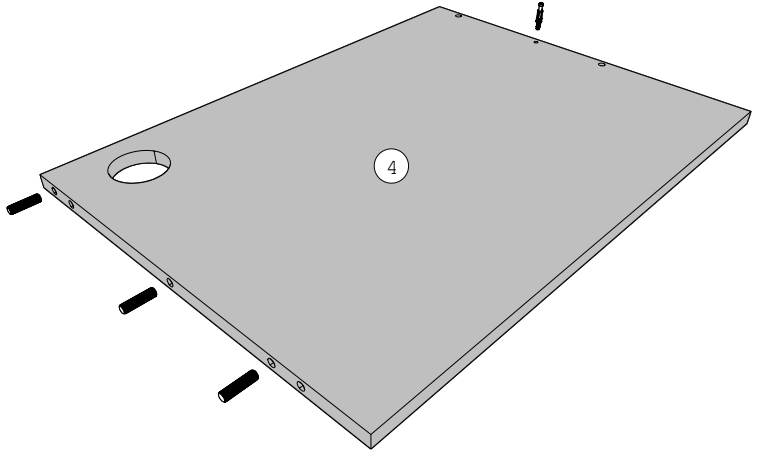
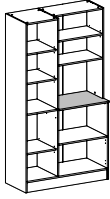

4 AI BRC
x1

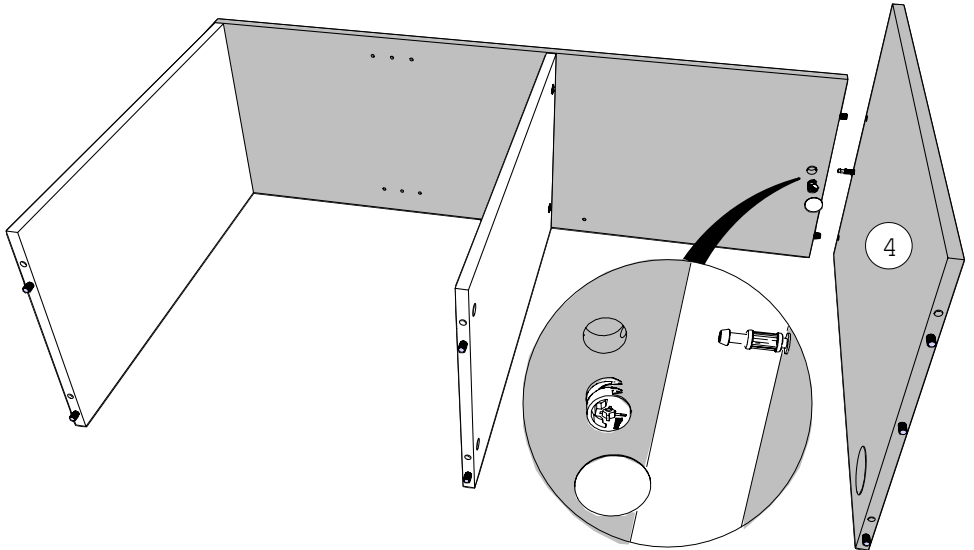
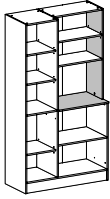

5

BSD



x6



ADM BR

x3

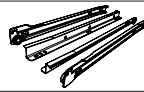

BWF

x2
VG



x1

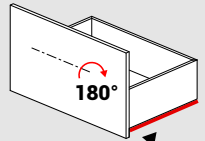
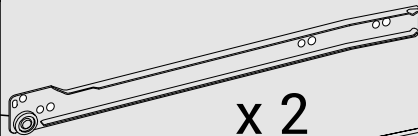
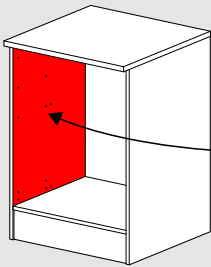
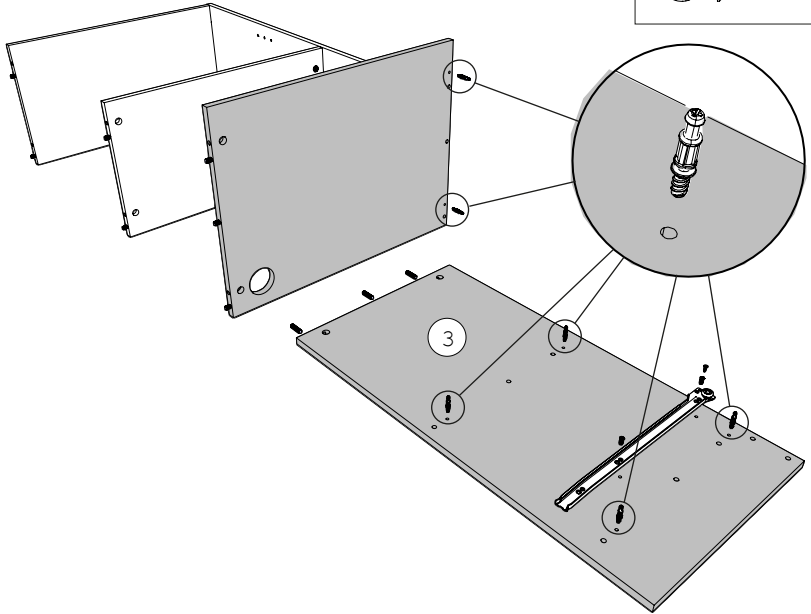
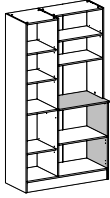

x 2

180°



1 & 2 = BWF
3 = VG

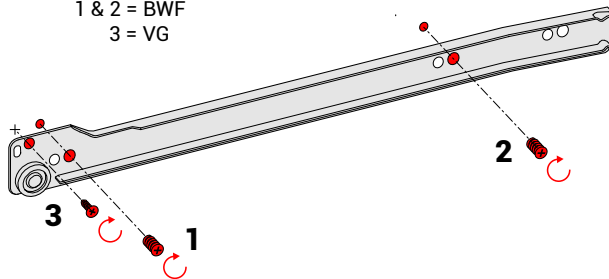

6

AI



x2

BRC

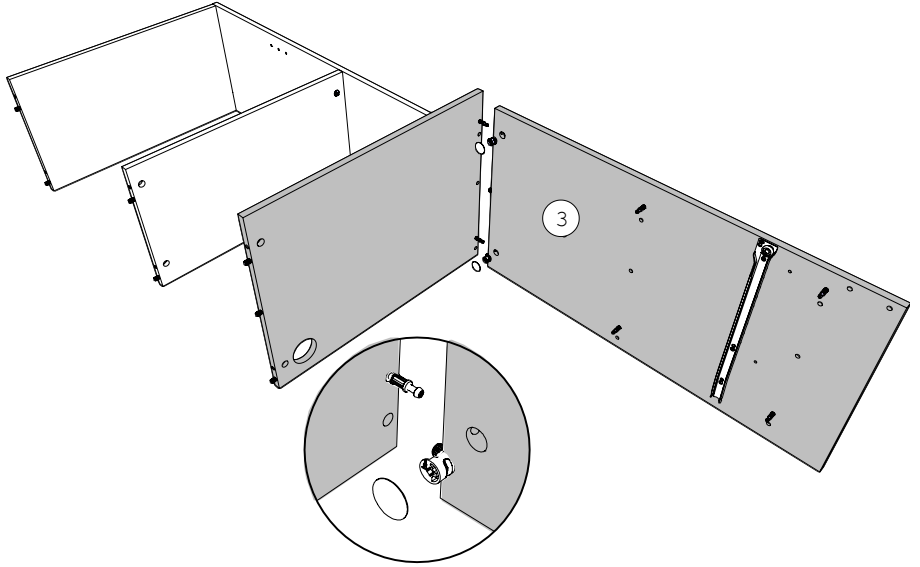
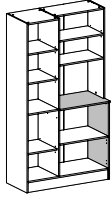

7



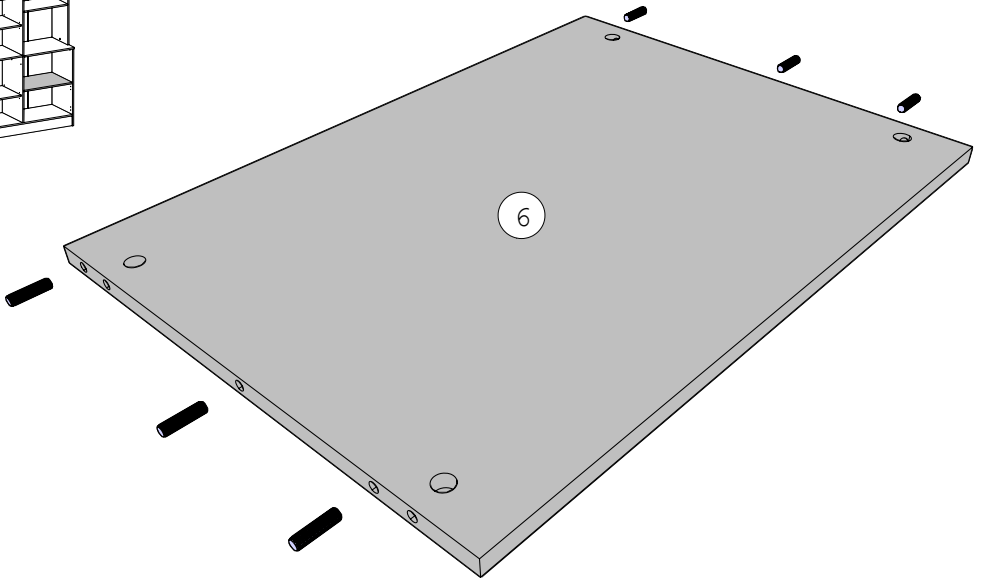
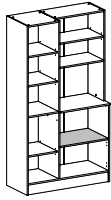

ADM

x6



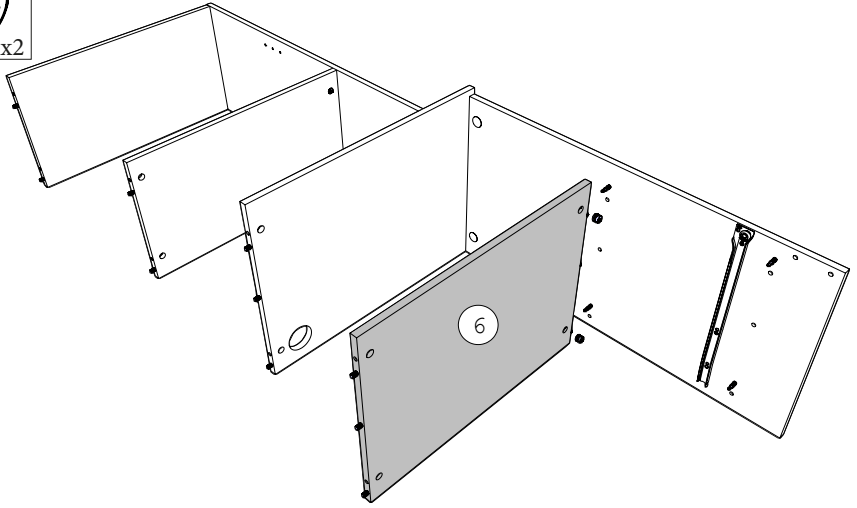
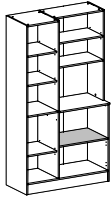



8 AI  x2

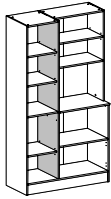

9 BSD  BR 



  12mm BWF 

VG   x1

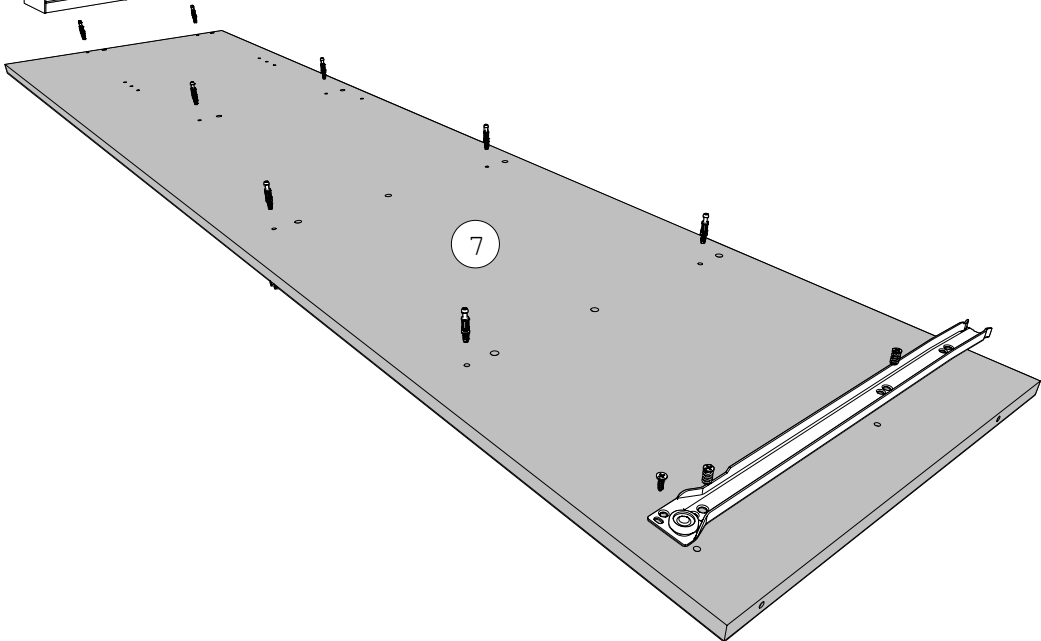

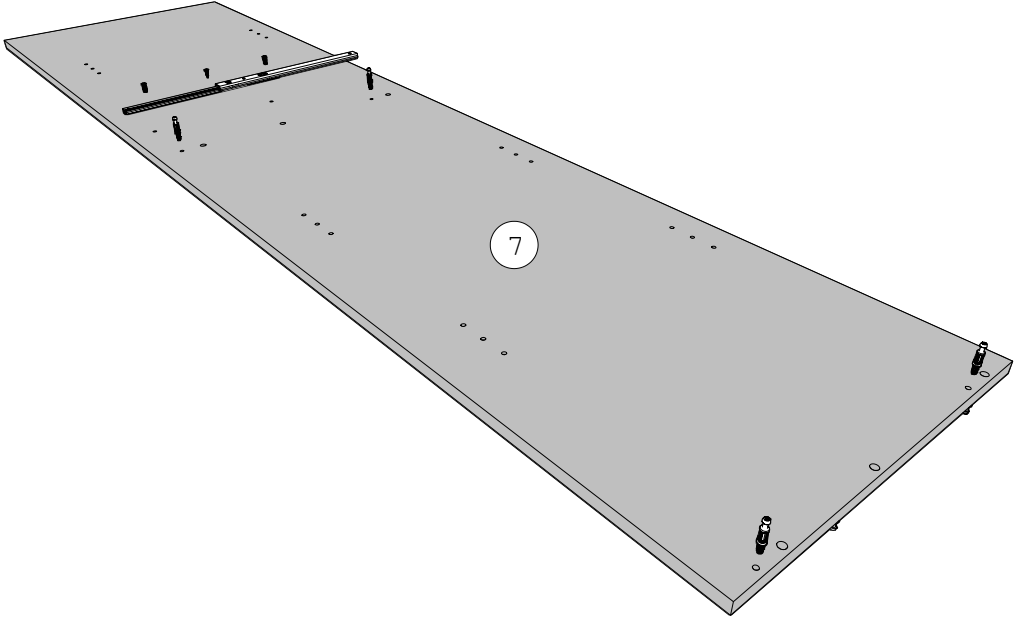
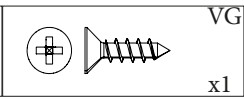
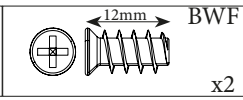
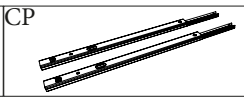
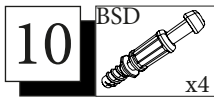

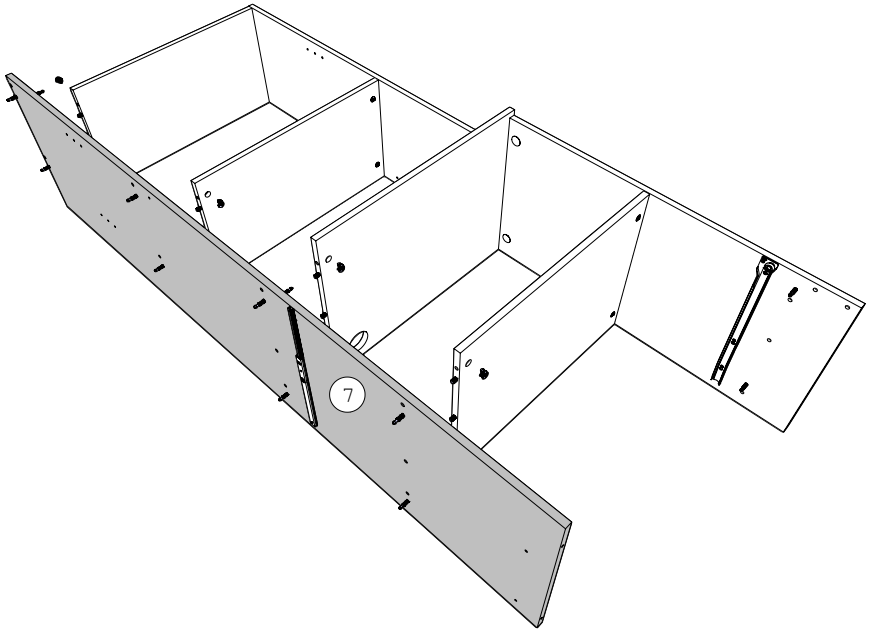
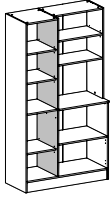

Extérieur du meuble	
1	
2	
3	

11 AI  x8



12   ADM x6

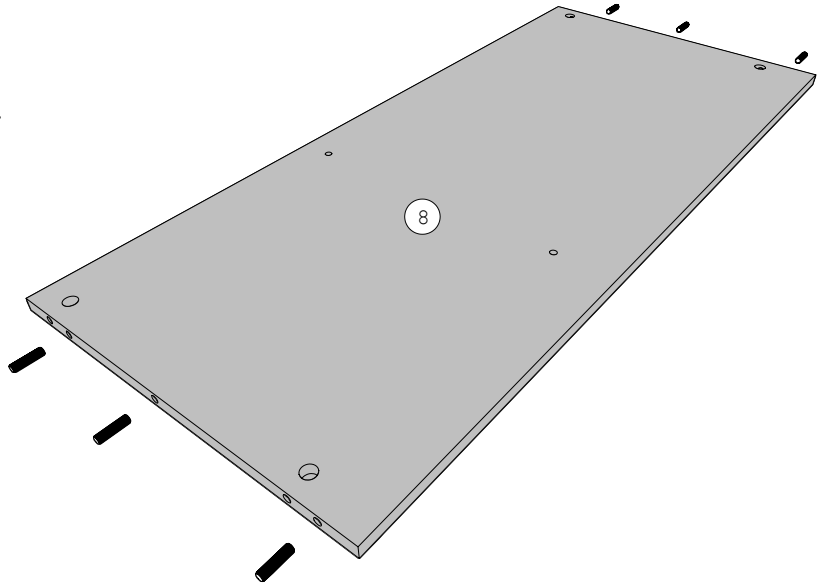
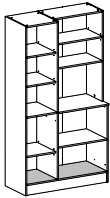

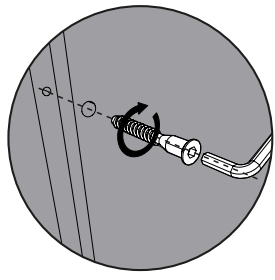
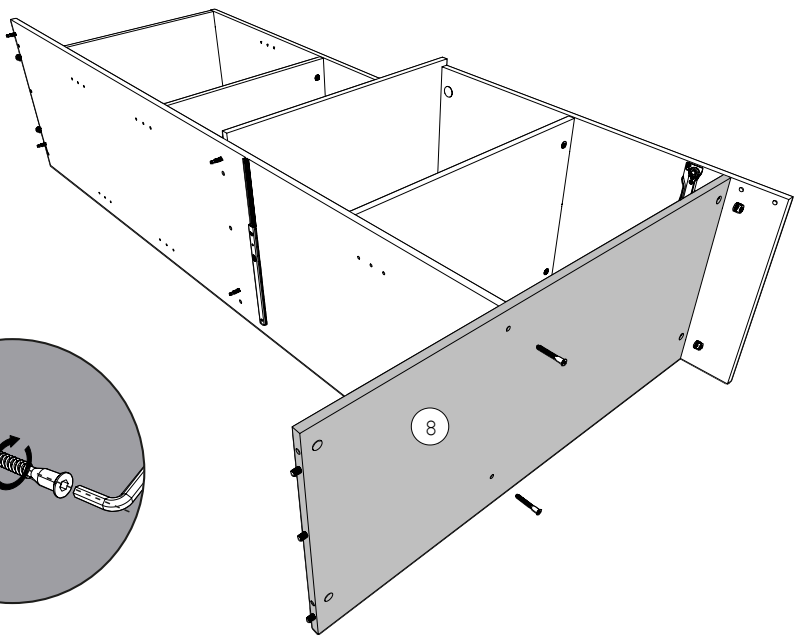
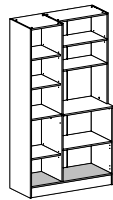

13 AI HWHV x2

x2



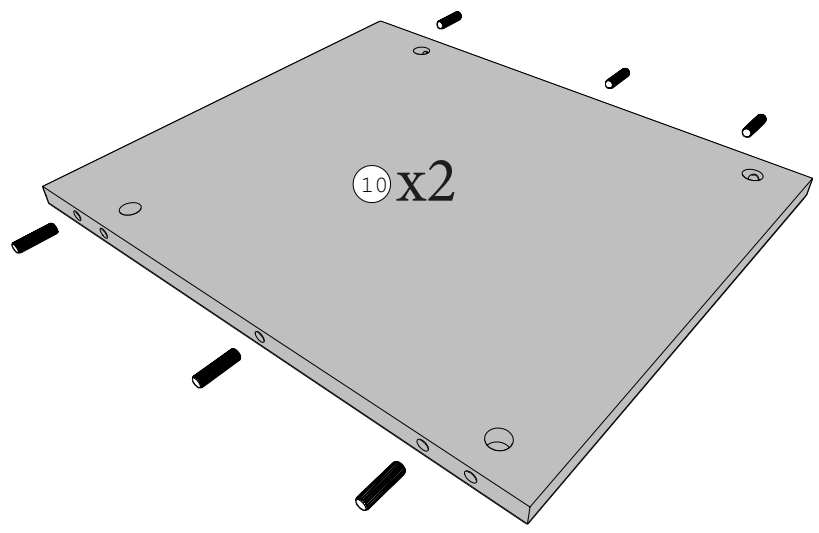
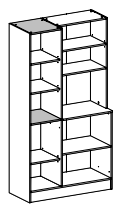



14 ADM x12

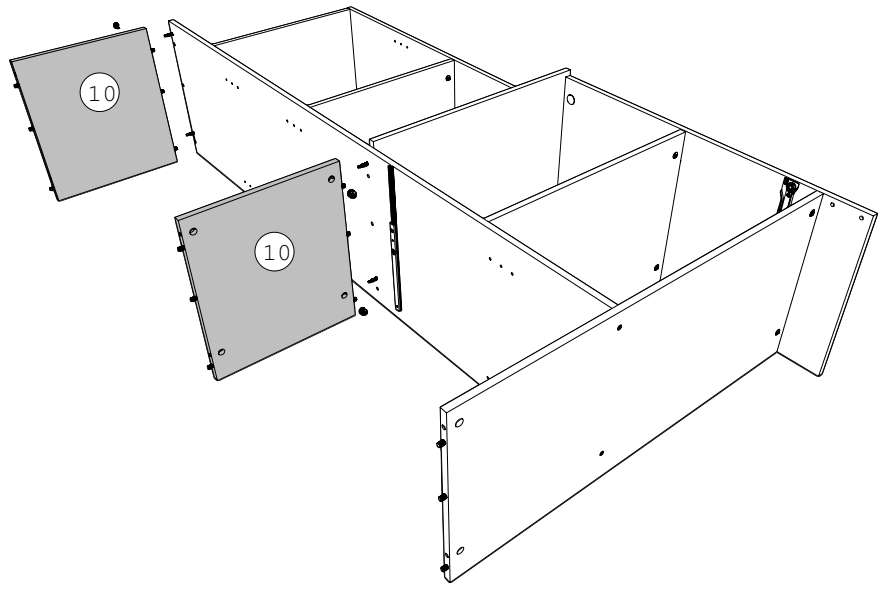
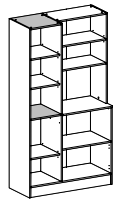

15 AI  x4

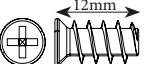
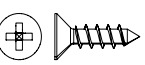

16	BSD  x6		 ADM CP x4		 12mm BWF x2
					 VG x1

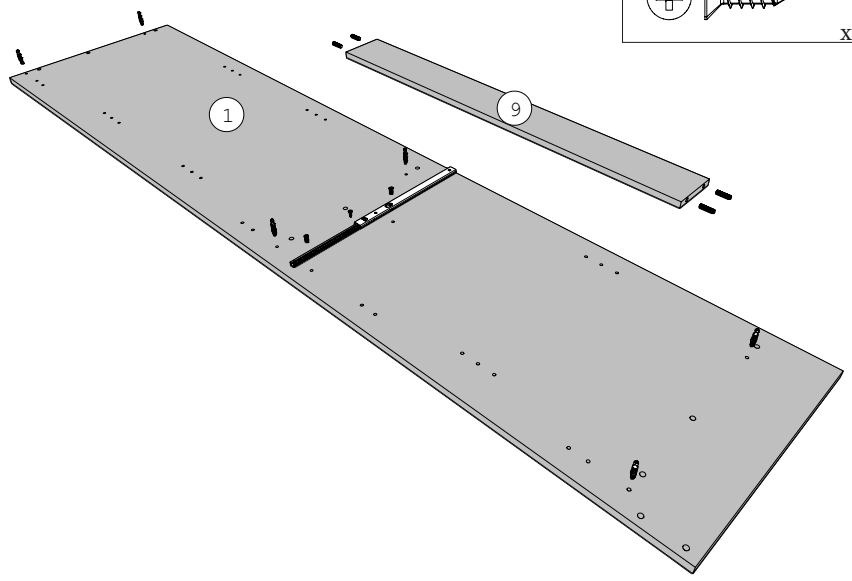
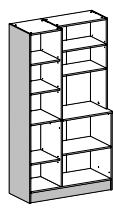

17 AI  x6

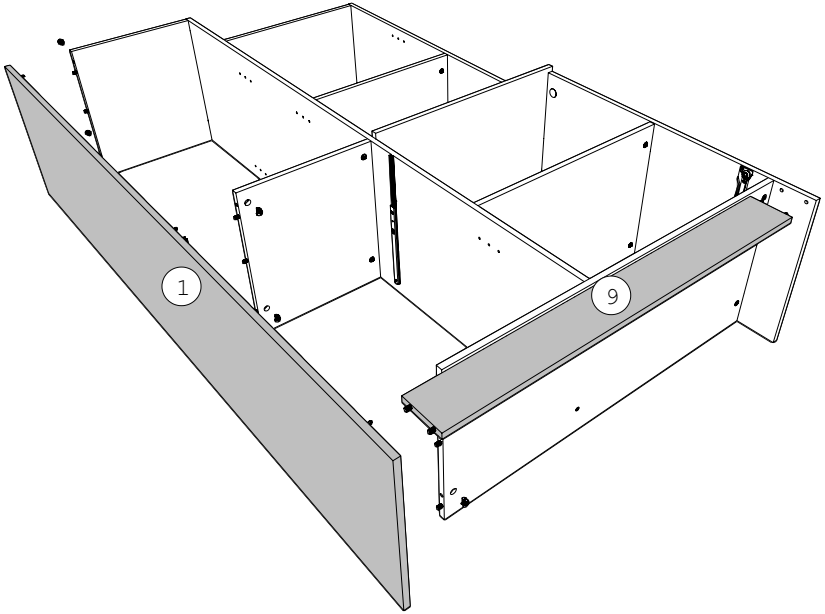
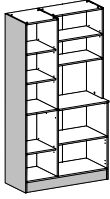

18

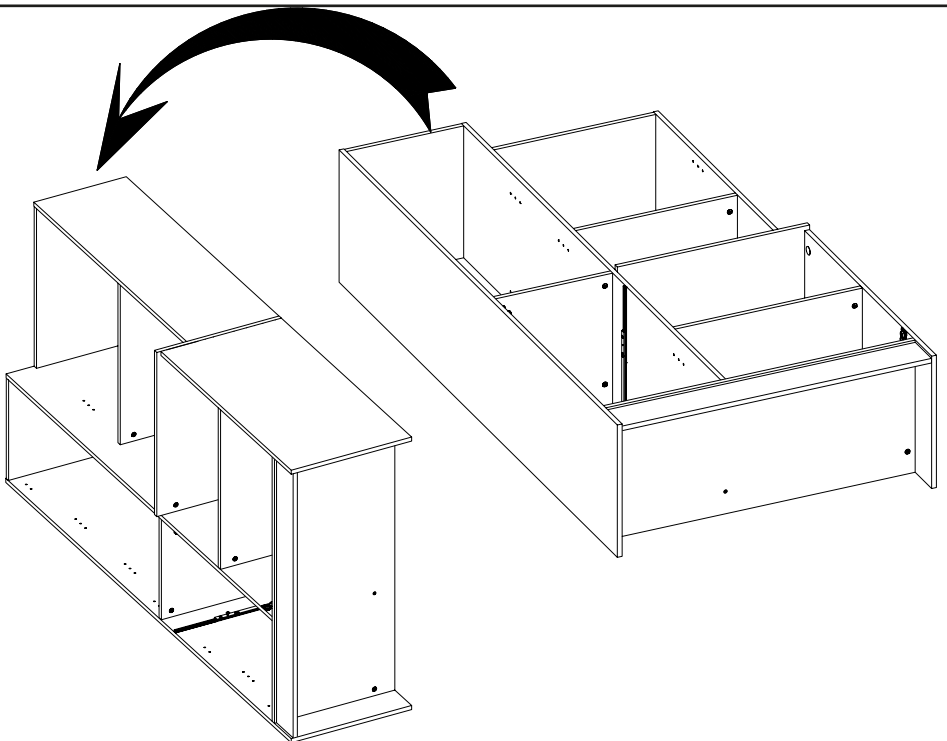

19

BQS



x5

XA



x1



VG

x3

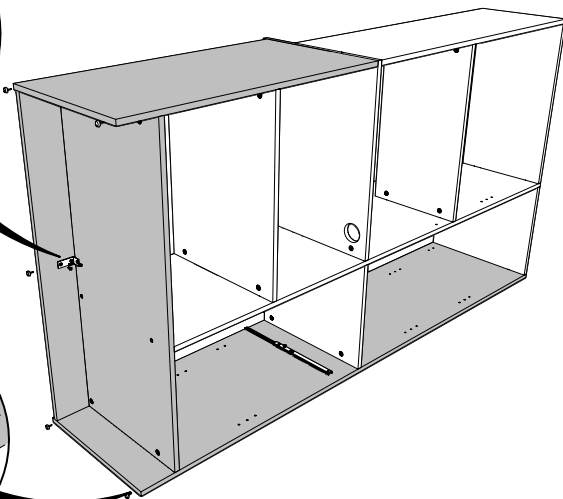
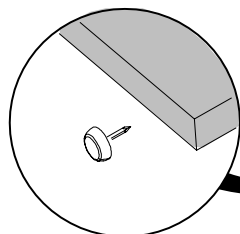
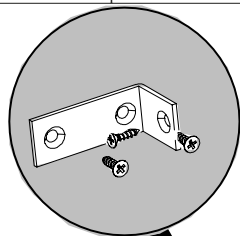
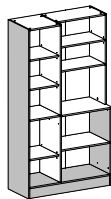

20

PA



x40

FA



x10

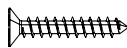

WJ

x10

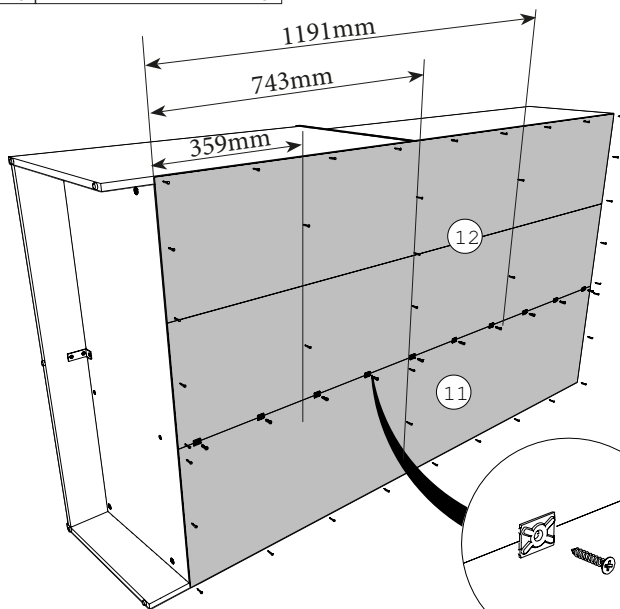
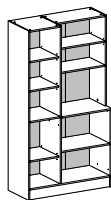

12

11

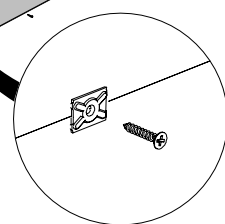

FR- Mesurer les diagonales du meuble pour vérifier l'équerrage. La mesure doit être identique.

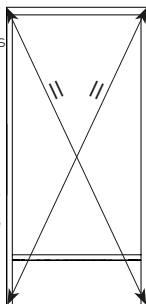

EN- Measure the diagonals of the piece of furniture to check for straightening. The measurement must be identical.

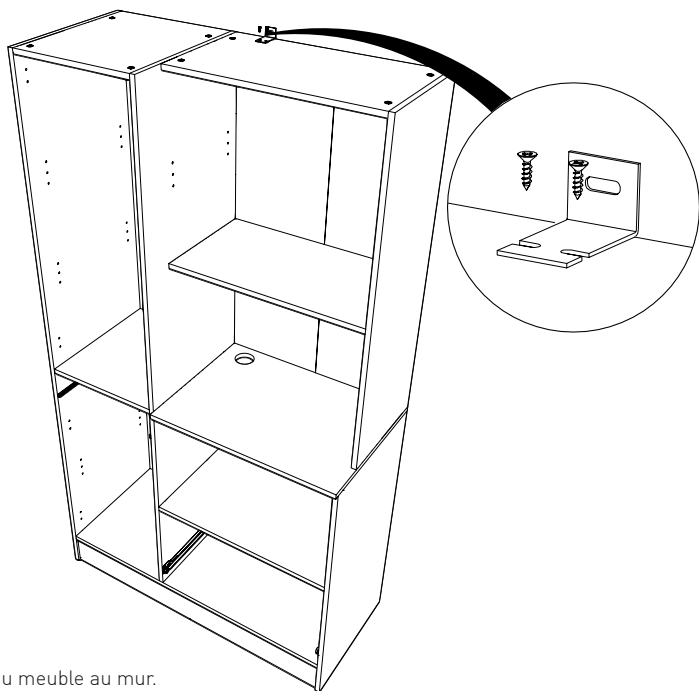
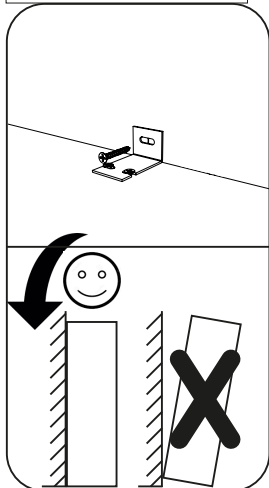
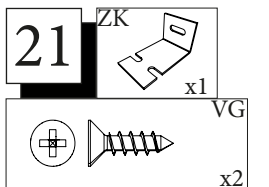

FR-Pour votre sécurité : Fixation du meuble au mur.

Attention, la fixation doit être réalisée par une personne compétente car cela nécessite des chevilles adaptées à la nature de votre mur.

EN-For your safety : the unit should be secured to the wall.

NB this should be carried out by a competent person as you must use the right rawl plug for your type of wall.

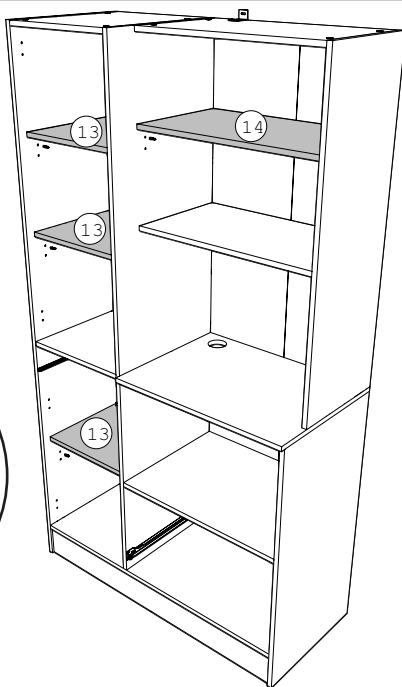
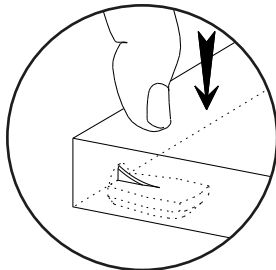
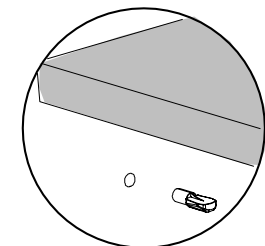
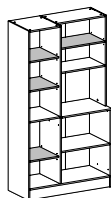

23

CF

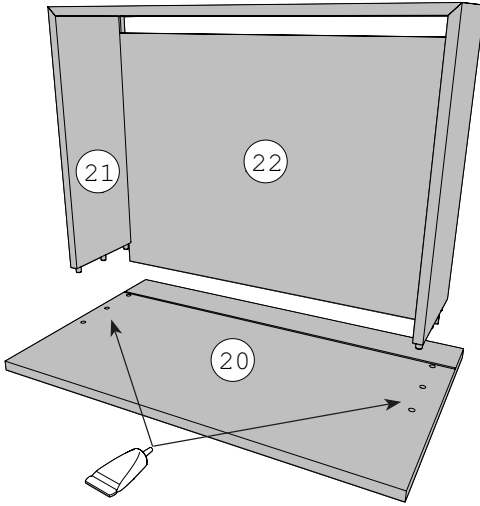
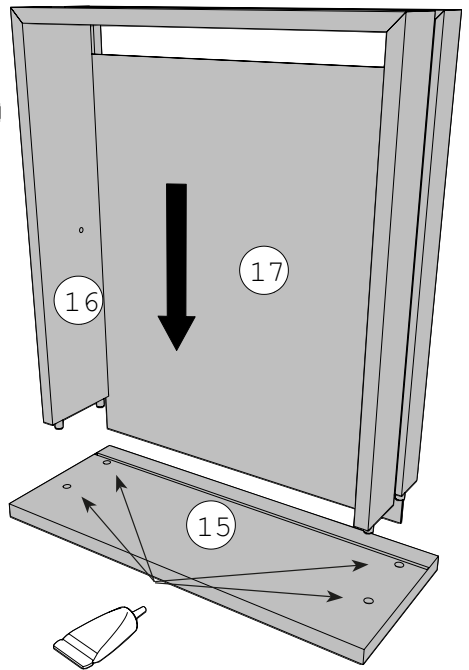
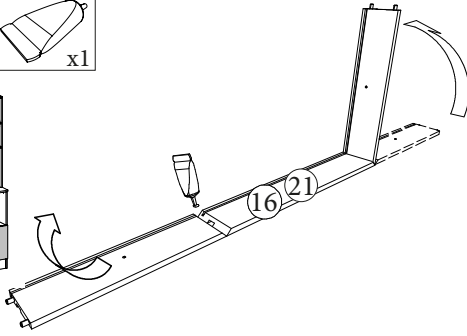
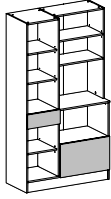

24

BXR



VG

x3

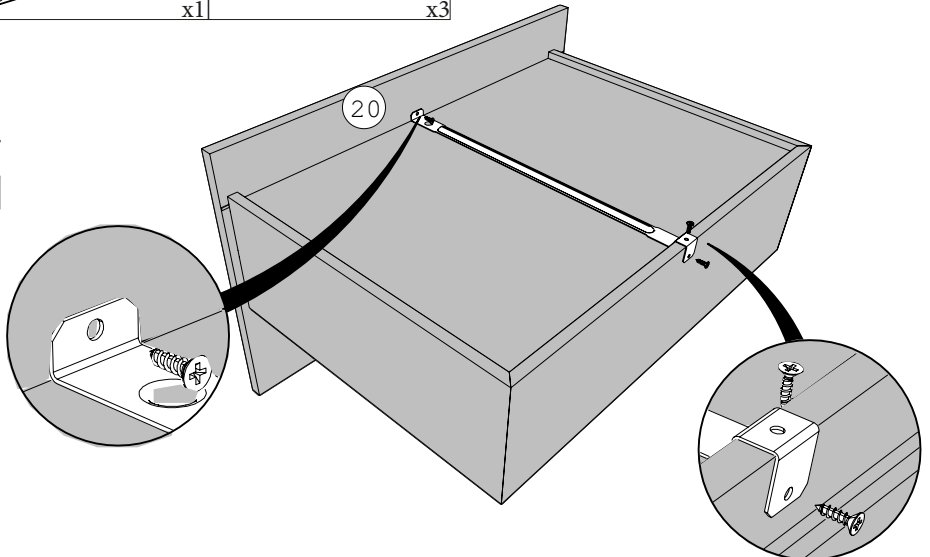
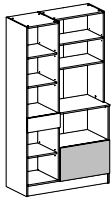

25 BR

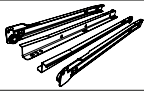

VG
x4

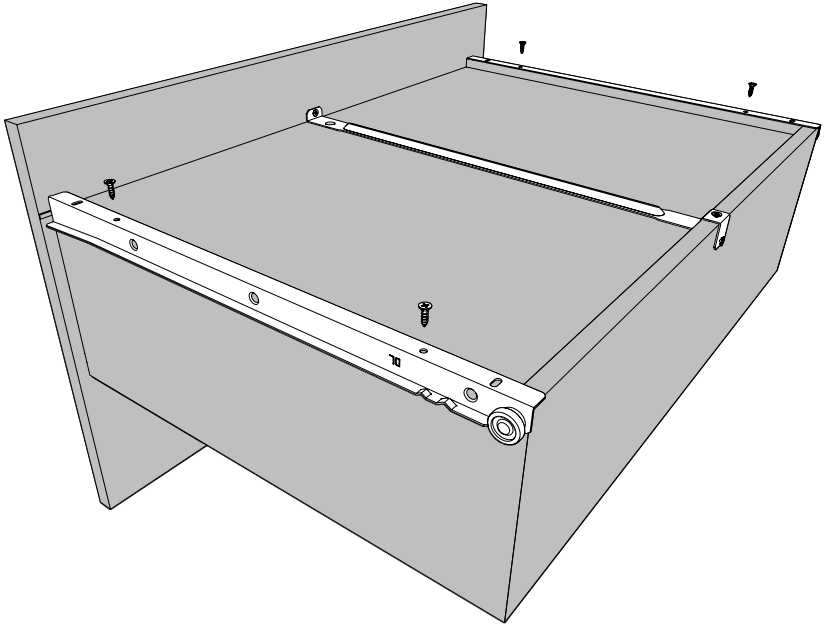
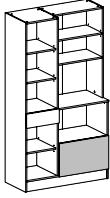



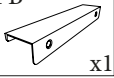

26 PB

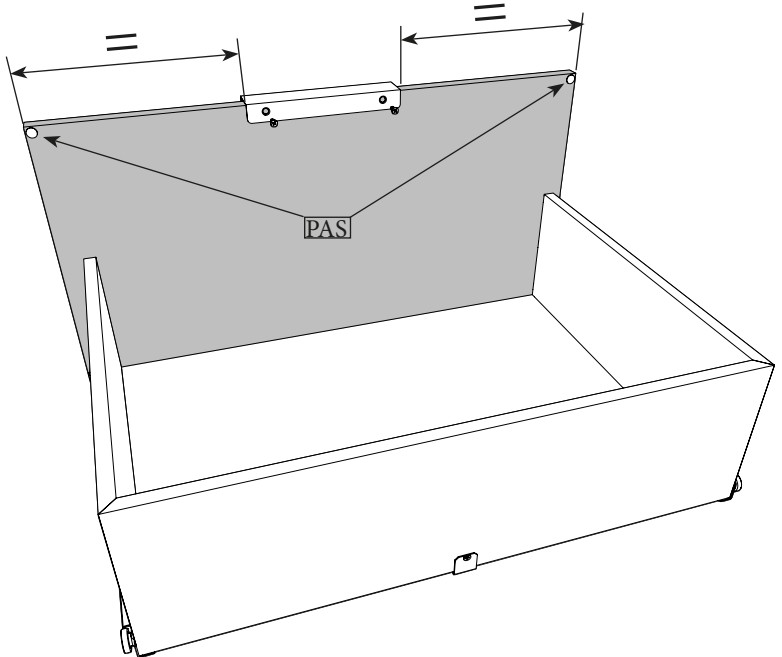
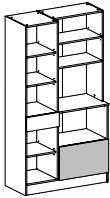

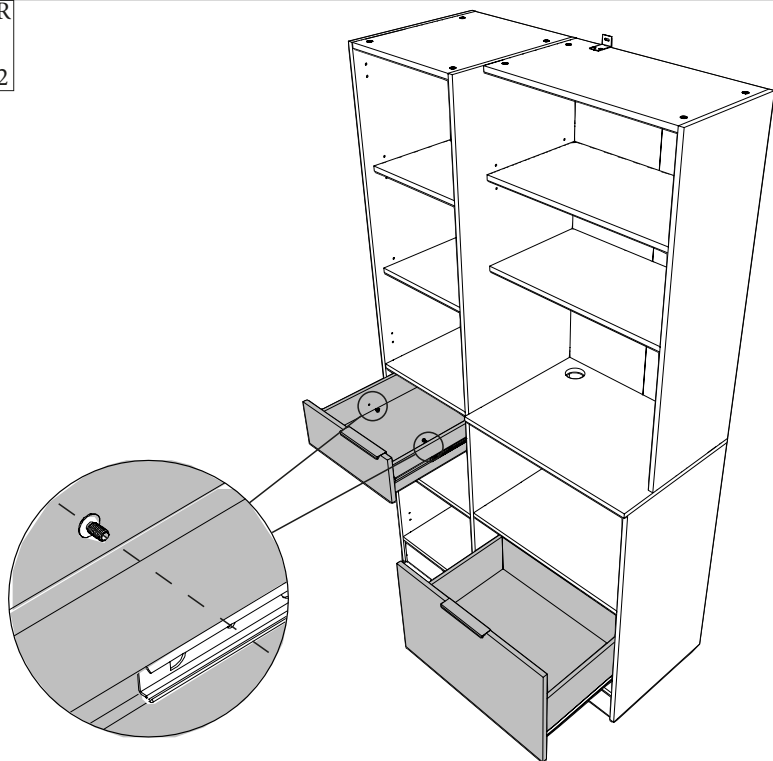
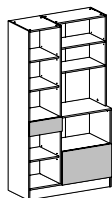
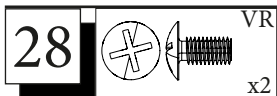
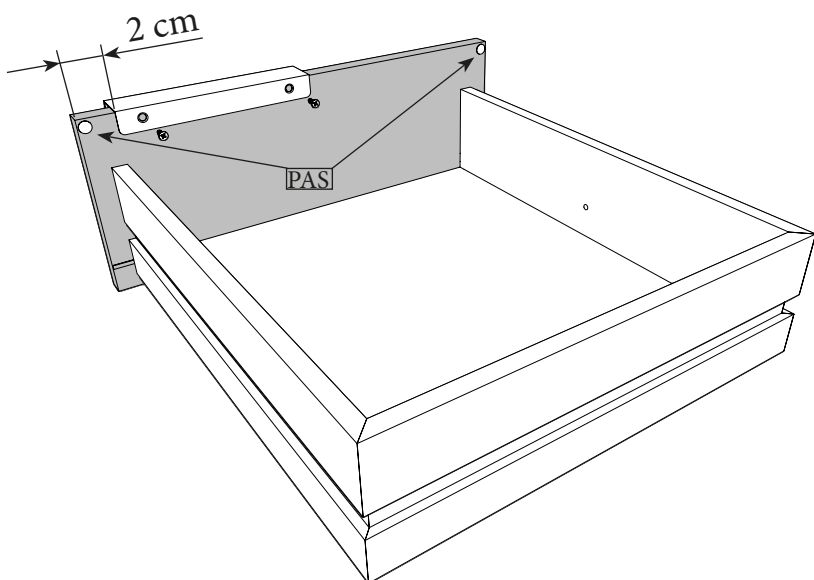
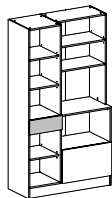
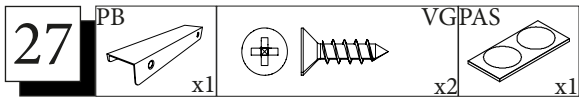



VGPAS

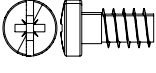

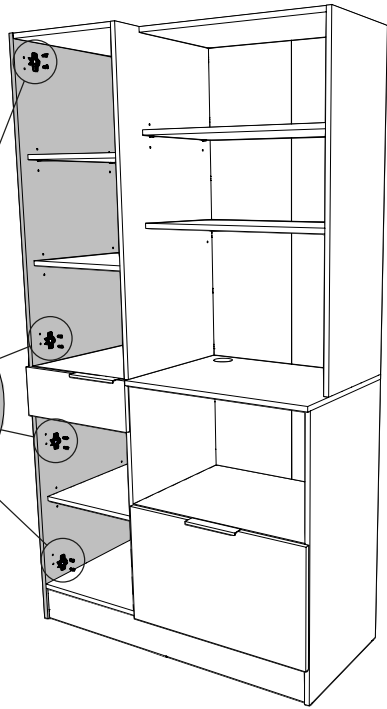
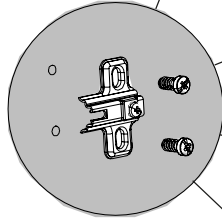
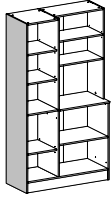

29	CDD	 	CDS
			

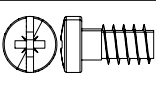

30	CDA	 	CDS
			

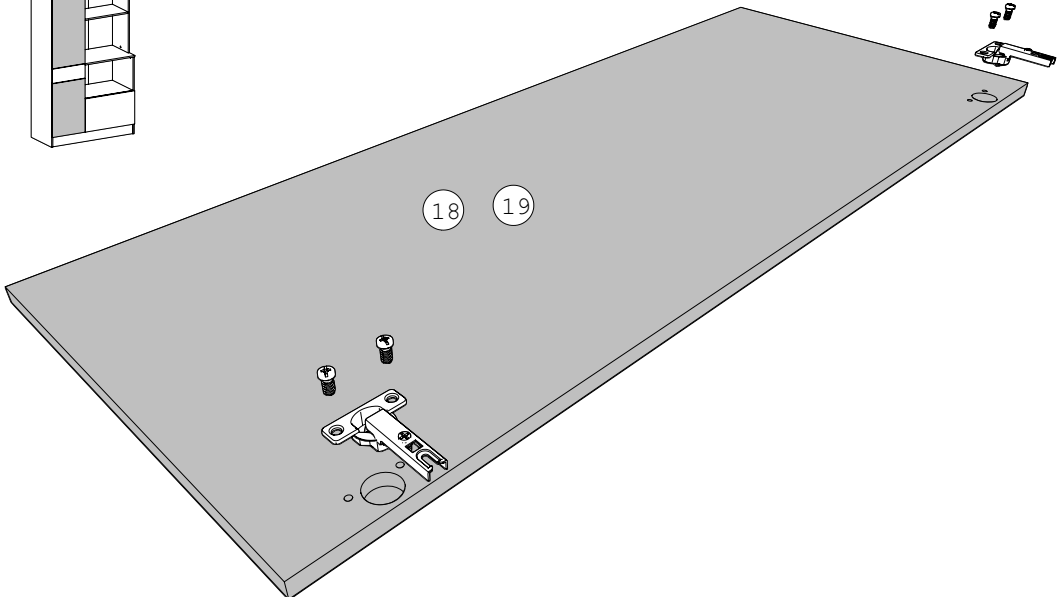
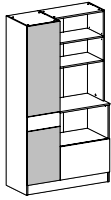

31

PB

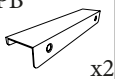

x2



VGPAS



x4

x2

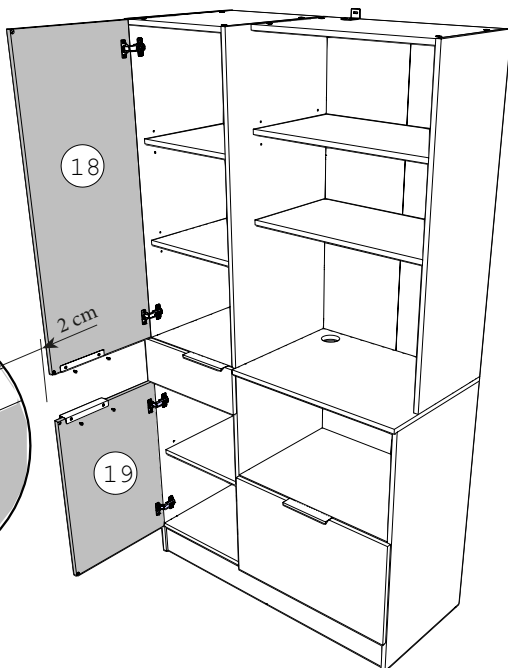
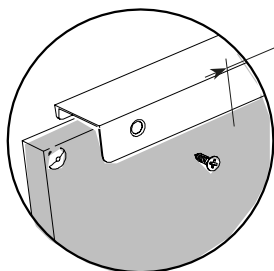
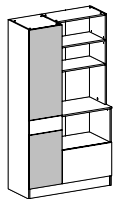

Charnières

<https://qrco.de/bc0wLm>

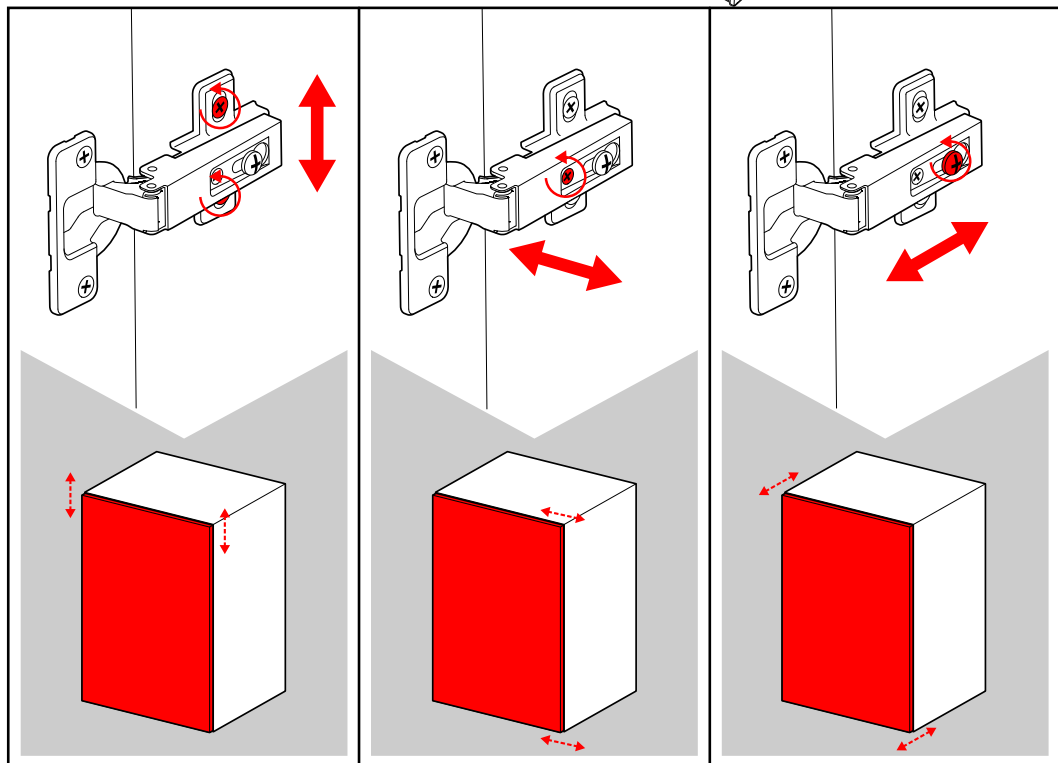

32

CNL



x2

CHK



x1

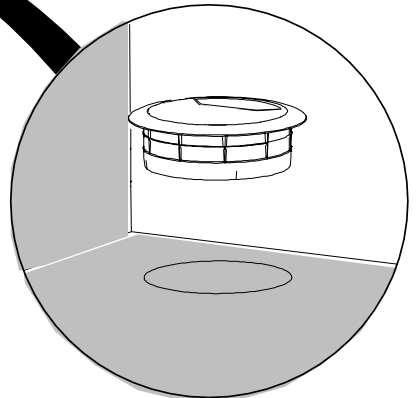
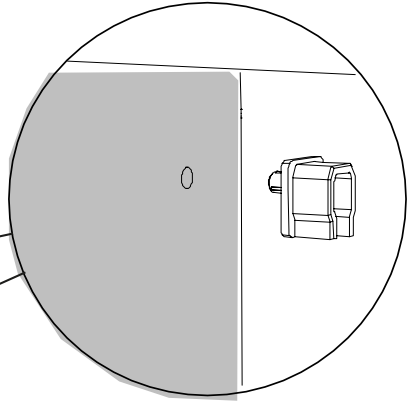
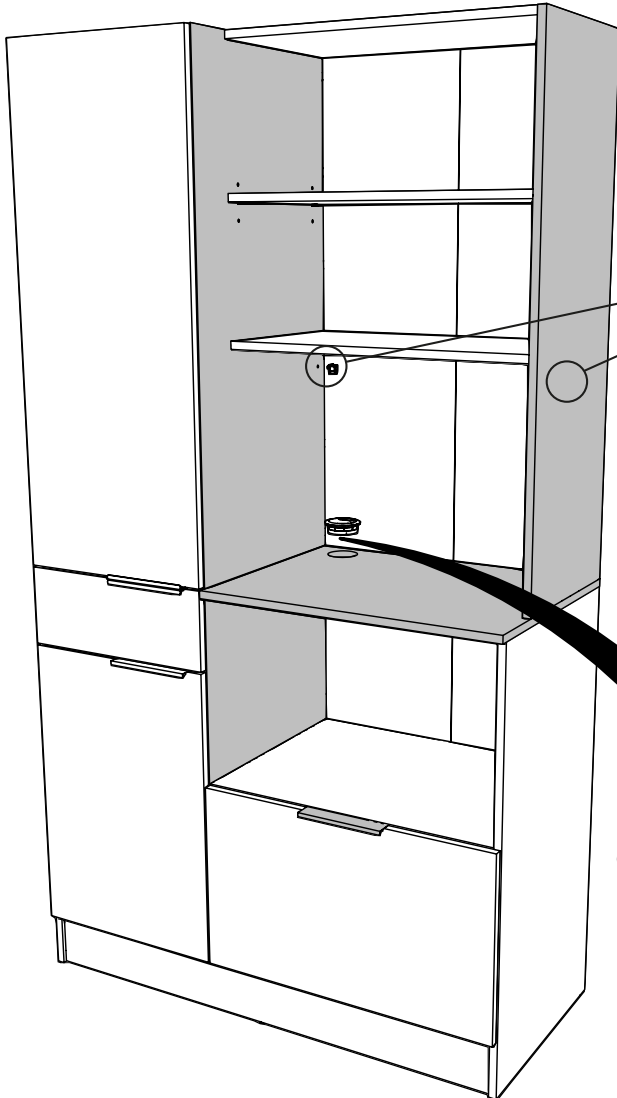
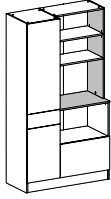

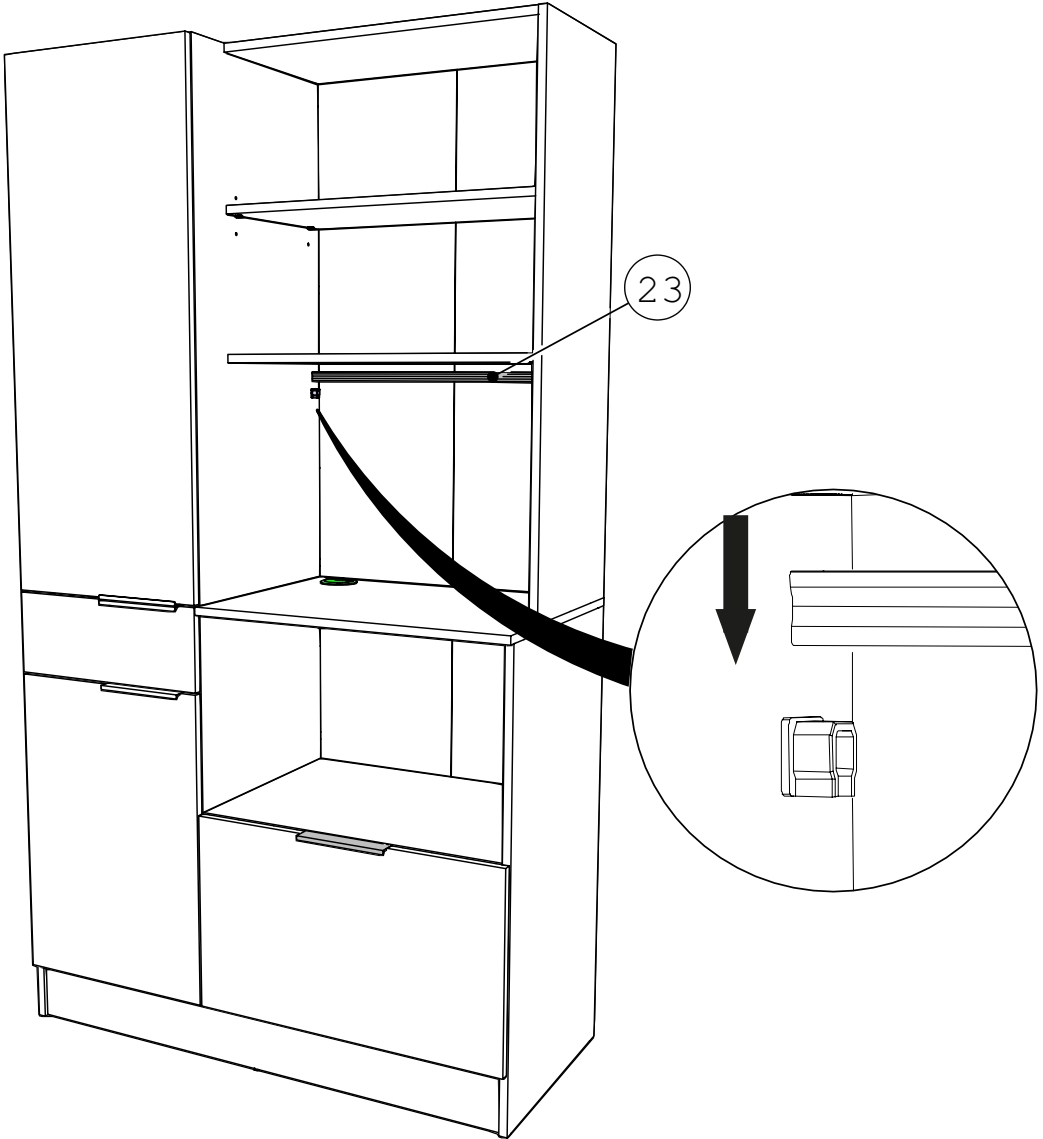

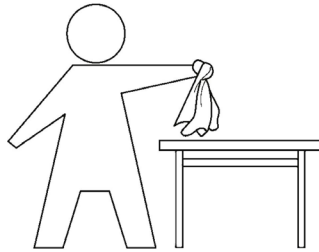

FR: INSTRUCTIONS GÉNÉRALES POUR LE MOBILIER CONSTITUÉ DE BOIS OU DE COMPOSITES DE BOIS (COMME LES SURFACES EN MELAMINÉ, STRATIFIÉ OU PLACAGE)

Nettoyer à l'aide d'un chiffon humide. Utiliser uniquement de l'eau ou un détergent doux. Essuyer à l'aide d'un chiffon propre.

EN: GENERAL INSTRUCTION FOR FURNITURE MADE OF WOOD OR WOOD COMPOSITES SUCH AS MELAMINE, LAMINATE OR VENEER SURFACES!

Wipe clean with a damp cloth. Use only water or a gentle detergent. Wipe dry with a clean cloth.



**LE TRI
+ FACILE**



FR

**Pensez à
donner ou recycler.**



Association

OU



Magasin

OU



Déchèterie

<https://quefairedemesdechets.fr>



EKIPA

0094NOTIC6273



ÎLOT DE CUISINE

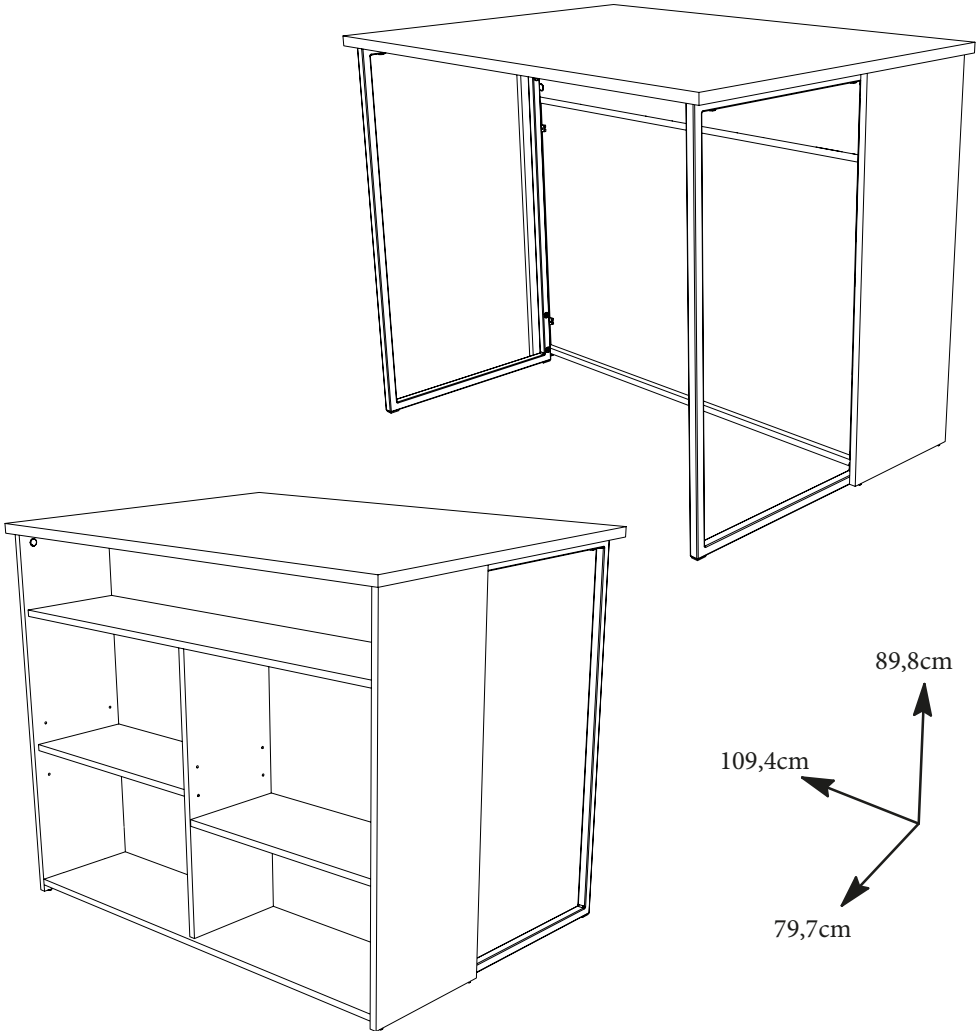

89,8cm

109,4cm

79,7cm

FR Remerciements :

Nous vous remercions d'avoir choisi un meuble créé et fabriqué par Ekipa et espérons qu'il vous donnera entière satisfaction.

EN Thanks :

Thank you for choosing furniture designed and manufactured by Ekipa. We hope you will totally satisfied with your purchase.

ES Agradecimientos :

Le damos las gracias por haber elegido un mueble diseñado y fabricado por Ekipa y esperamos que sea de su total agrado.

DE Danksagung:

Wir bedanken uns bei Ihnen das Sie bei uns ein Möbel welches von Ekipa entworfen und hergestellt wurde. Wir hoffen zu Ihrer besten Zufriedenheit gearbeitet zu haben.



Temps de montage : 1h15



contact@parisot.com



Conseils de préparation au montage : 15 min

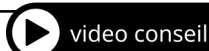

<https://qrco.de/bcJeNz>

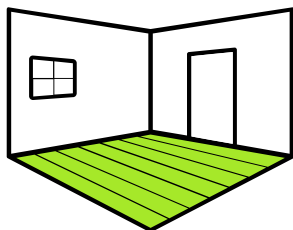

Faire un peu de place

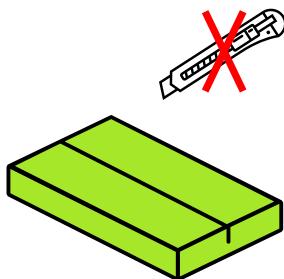

Pas d'outils tranchants

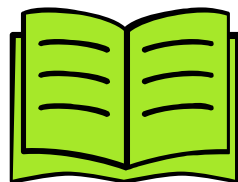

Bien suivre les instructions de la notice de montage

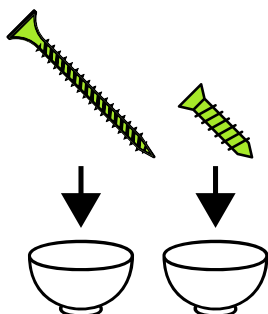

Trier vos quincailleries

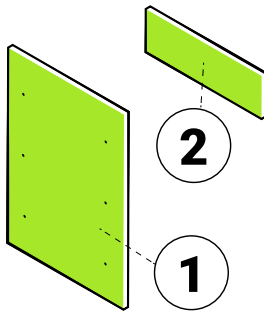

Repérer vos pièces

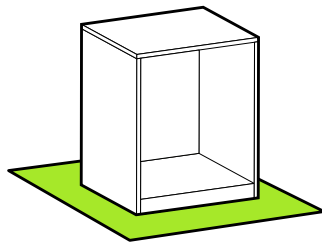

Protéger votre sol

Matériel nécessaire

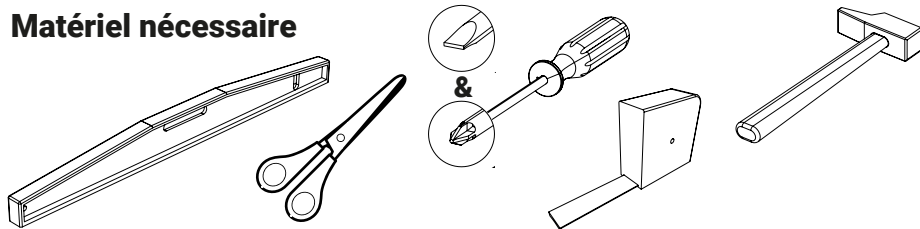

Conseils d'entretien

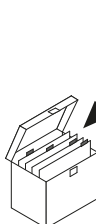

✂ Numérotez vos pièces à l'aide de «Post-it» non fournis

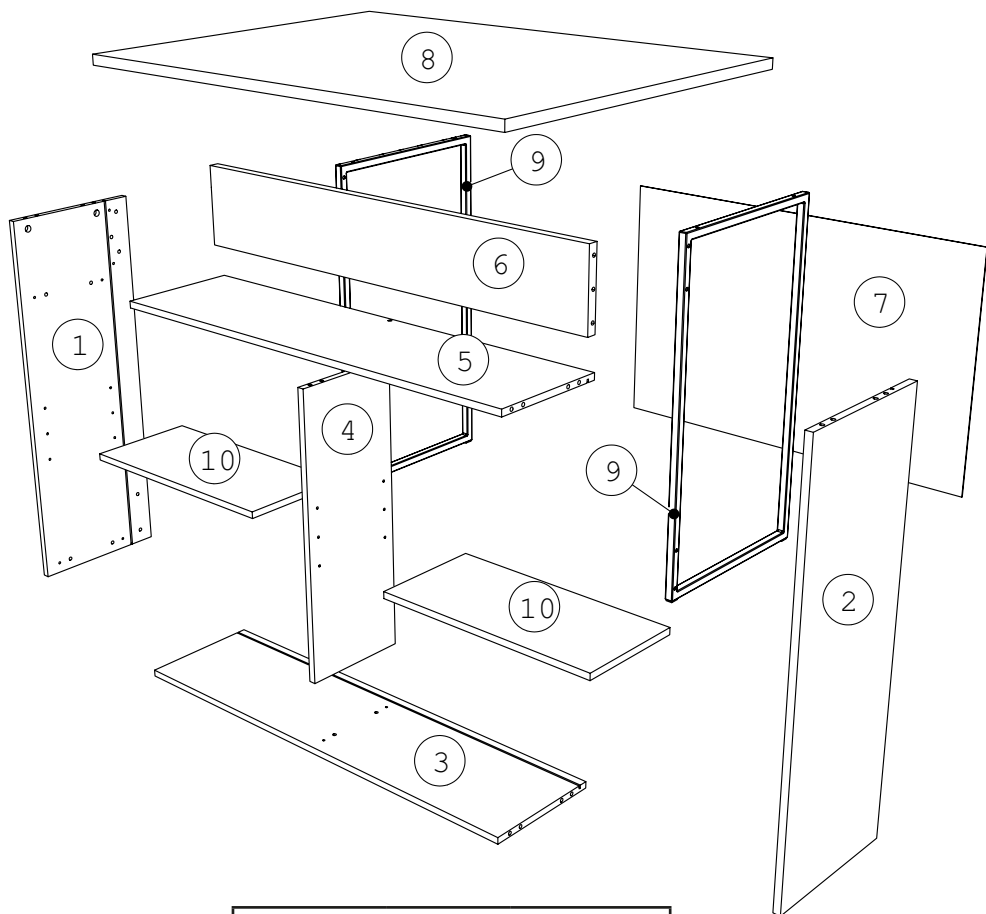

		cm		
Rep	Qté	Longueur	largeur	Epaisseur
01	1	87,2	31,7	1,5
02	1	87,2	31,7	1,5
03	1	103,8	27,4	1,5
04	1	64,9	24,2	1,5
05	1	103,8	26,5	1,5
06	1	103,8	17,65	2,2
07	1	105,0	66,2	0,25
08	1	109,4	79,7	2,2
09	2	87,6	49	2
10	2	51,1	24,1	1,5



0 1cm 2 3 4 5

<p>FO</p>	<p>x2</p>	
<p>VAF8</p>	<p>x2</p>	
<p>AGN</p>	<p>x1</p>	
<p>BGZ</p>	<p>x12</p>	<p>BLL</p> <p>x2</p>
<p>ADM</p>	<p>x18</p>	<p>APM</p> <p>x12</p> <p>BRC</p> <p>x2</p> <p>EP</p> <p>x4</p>
<p>HW</p>	<p>x1</p> <p>HV</p> <p>x1</p> <p>BQS</p> <p>x4</p> <p>BXC</p> <p>x1</p> <p>BWD</p> <p>x8</p> <p>BSD</p> <p>x20</p> <p>AI</p> <p>x20</p>	

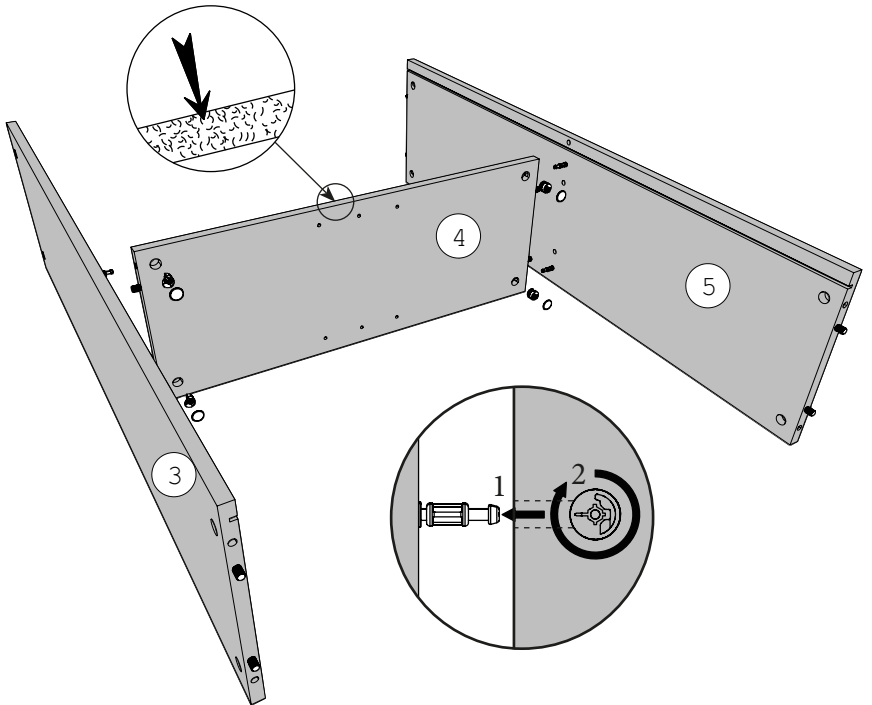
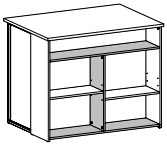
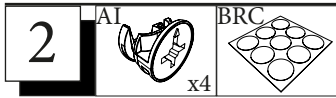
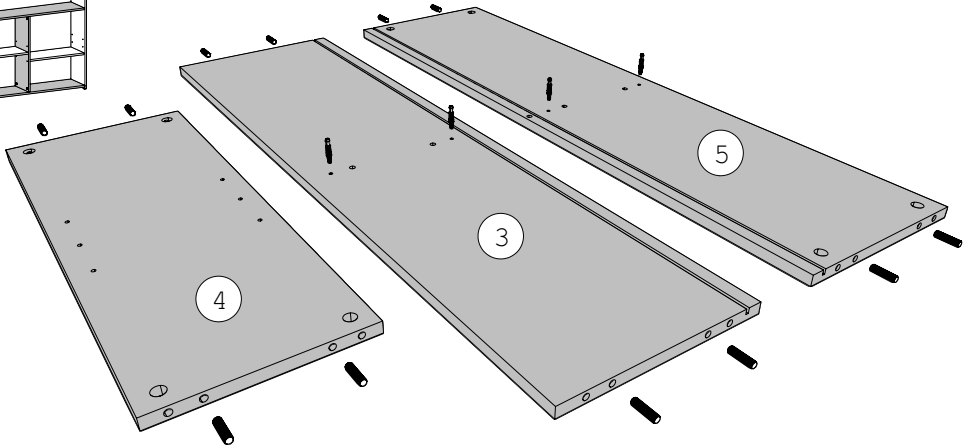
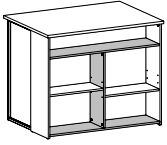
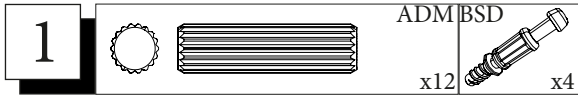

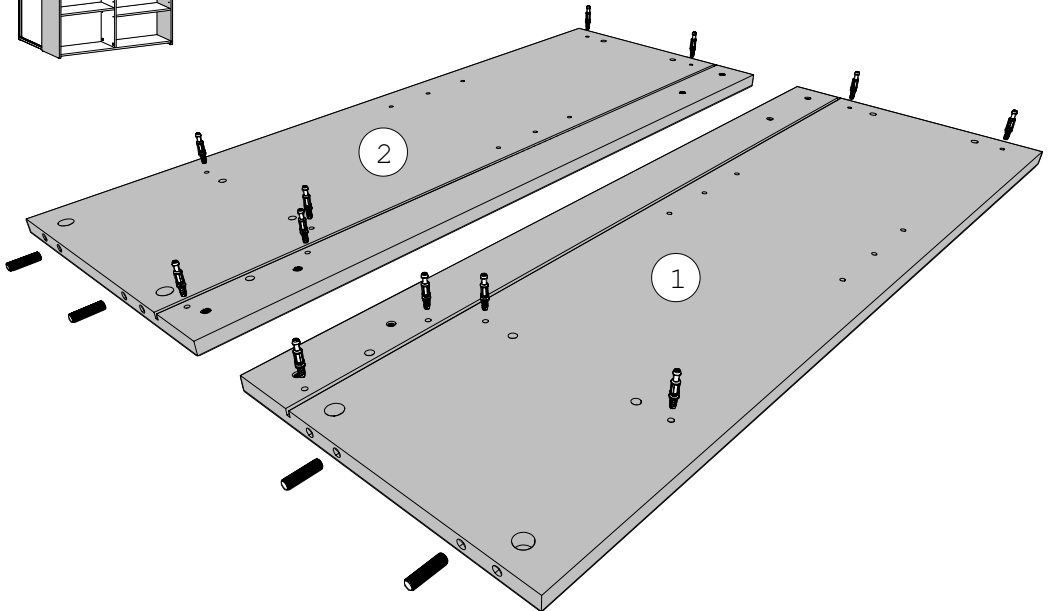
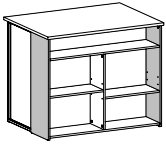
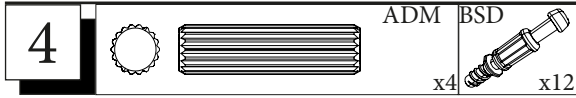
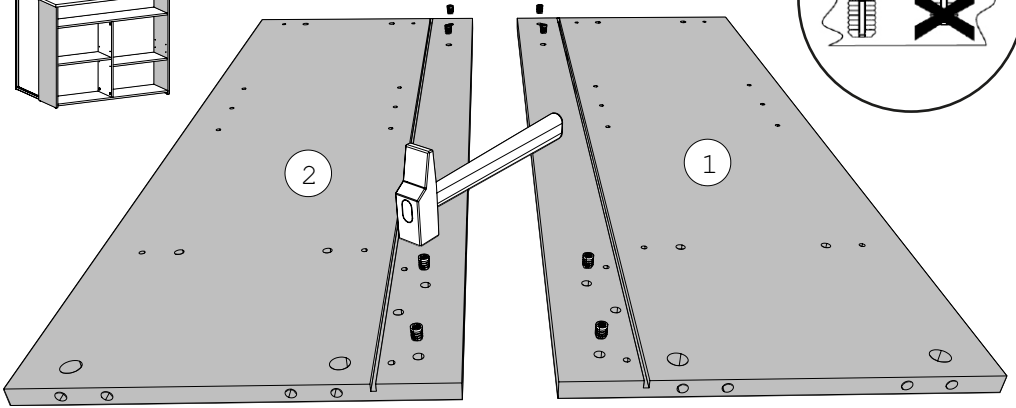
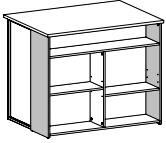

5

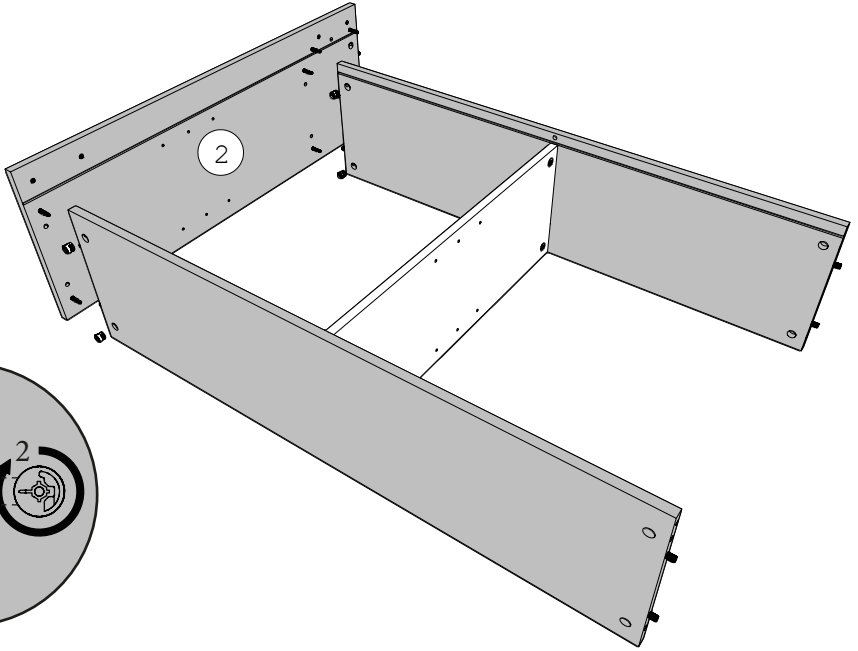
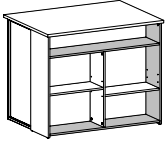
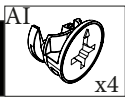

6

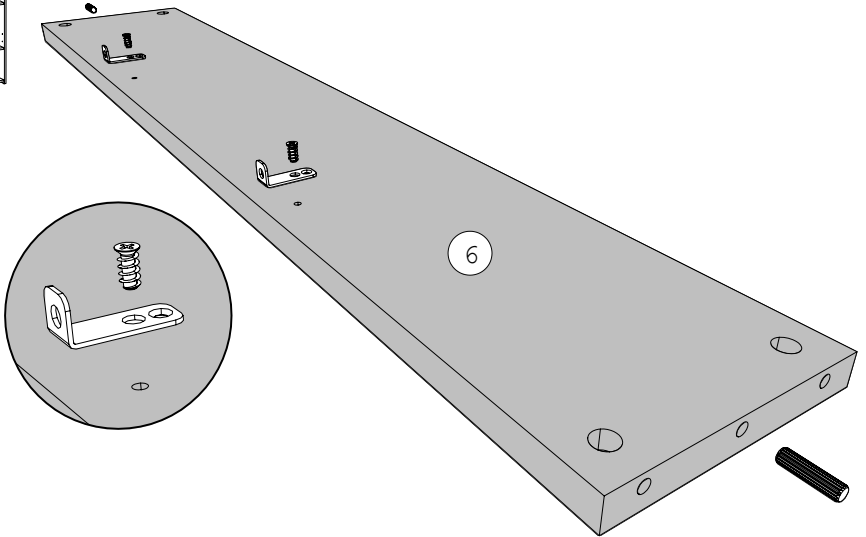
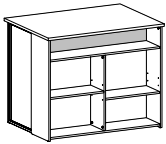
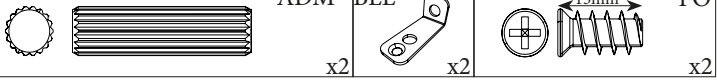

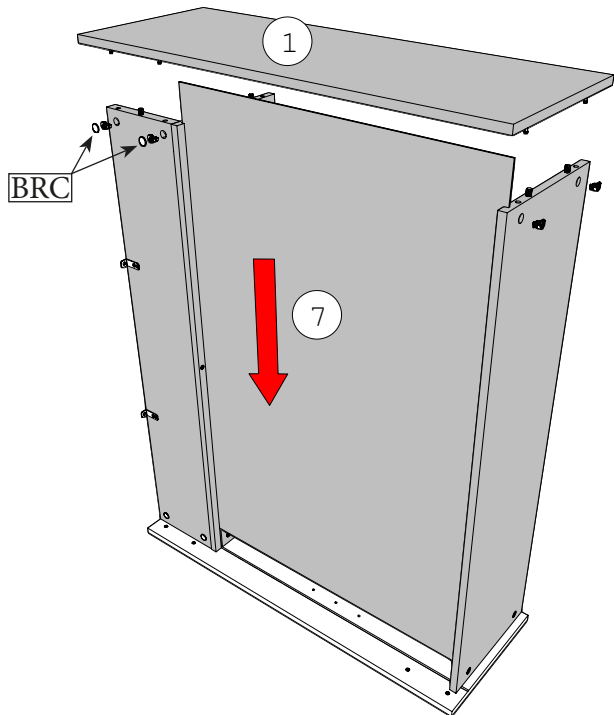
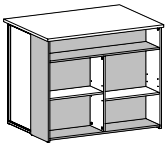
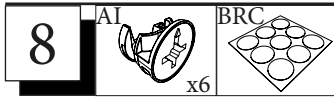
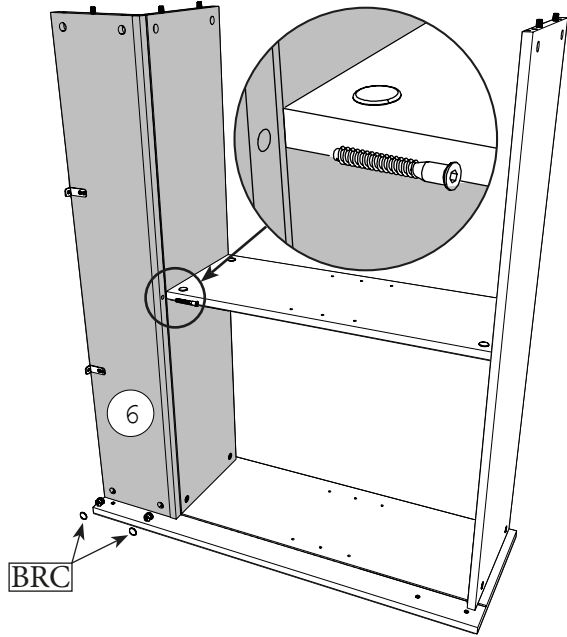
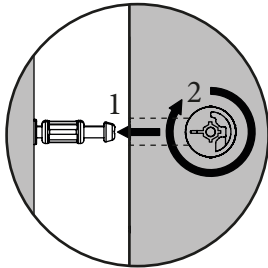
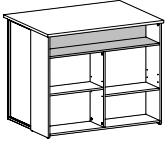
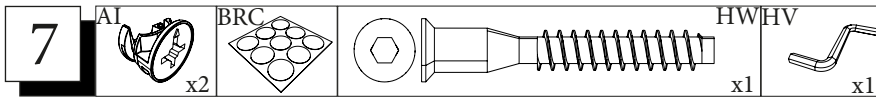

9

BXC



x1



AGN

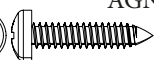

x1

BQS



x4

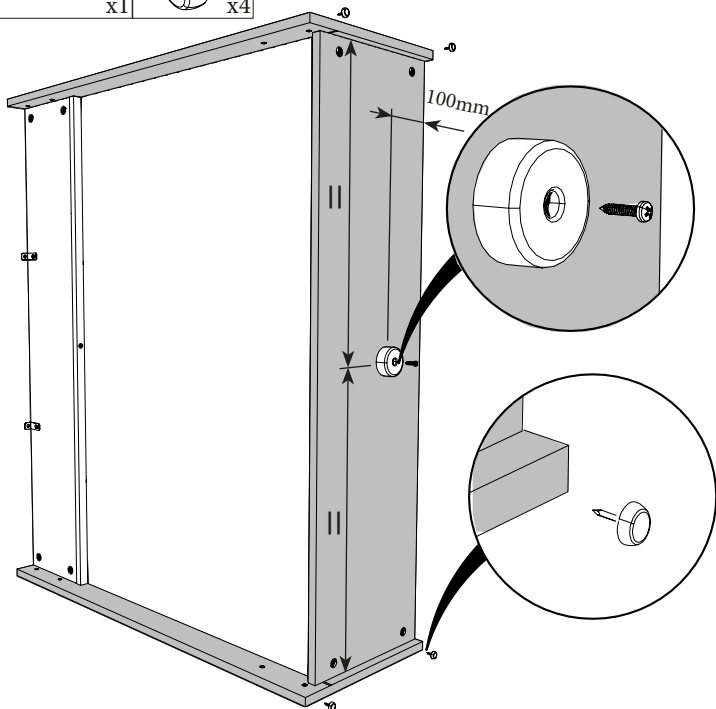
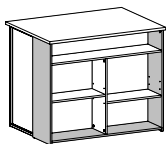

10

EP



x4

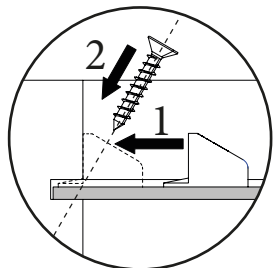
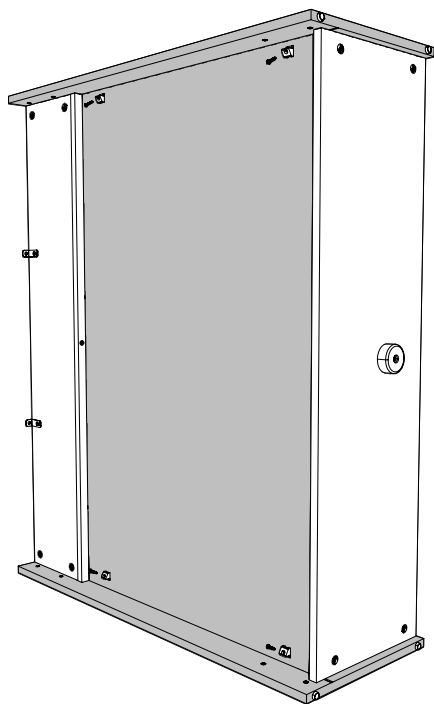
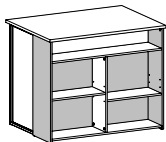

FR- Mesurer les diagonales du meuble pour vérifier l'équerrage. La mesure doit être identique.

EN- Measure the diagonals of the piece of furniture to check for straightening. The measurement must be identical.

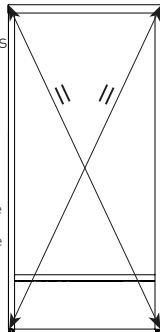

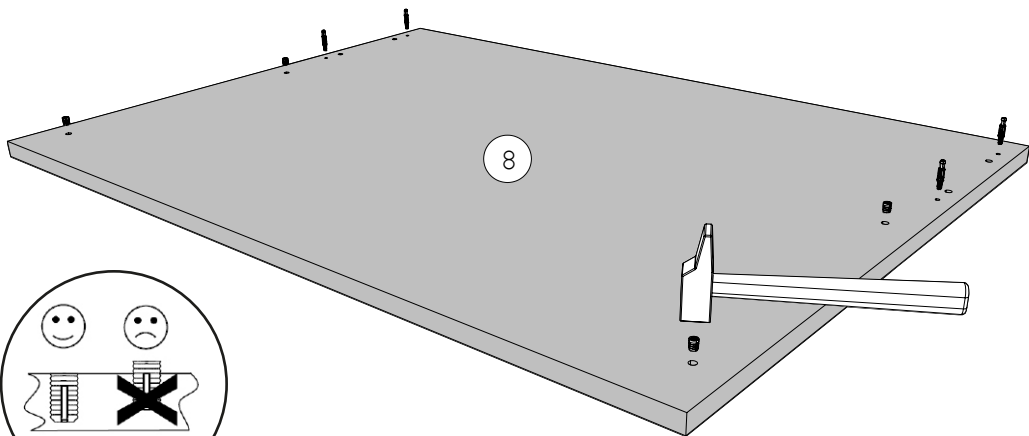
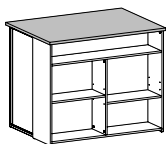
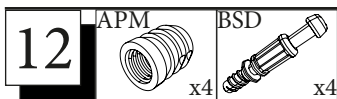
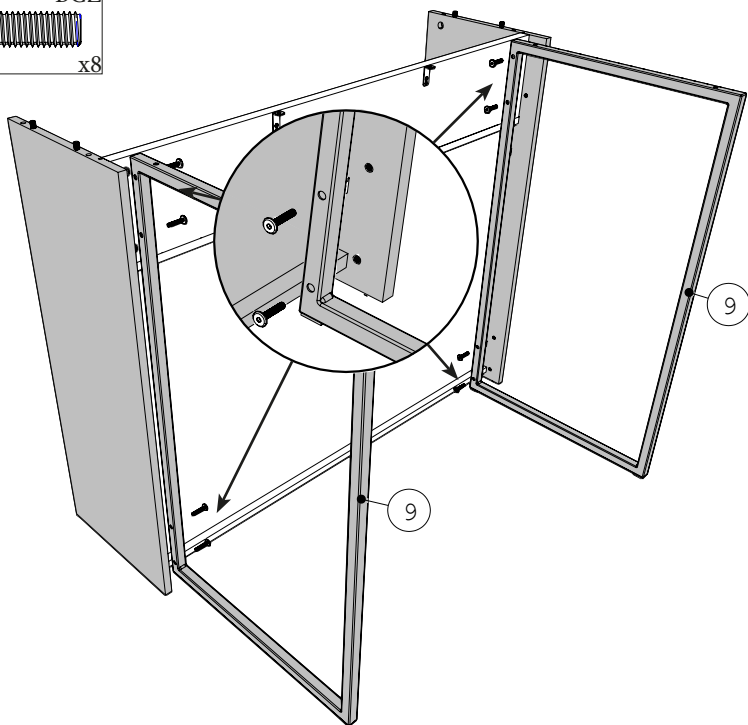
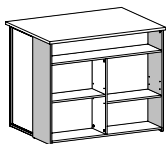
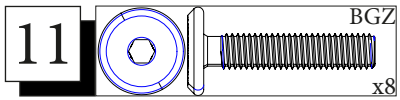

13 AI BRC
x4

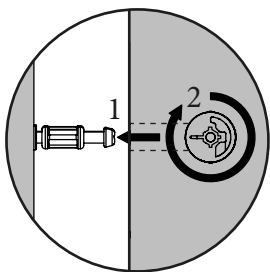
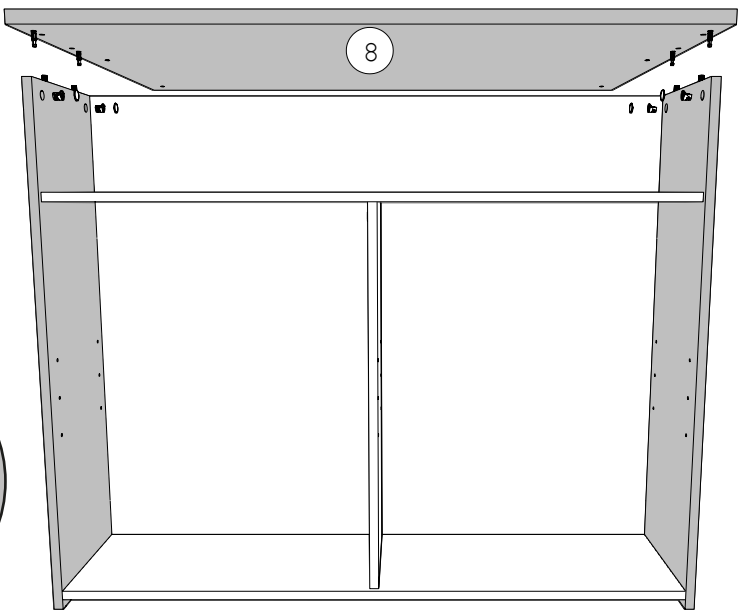
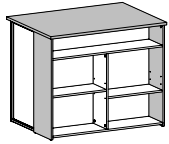

14 BGZ VAF8
x4 x2

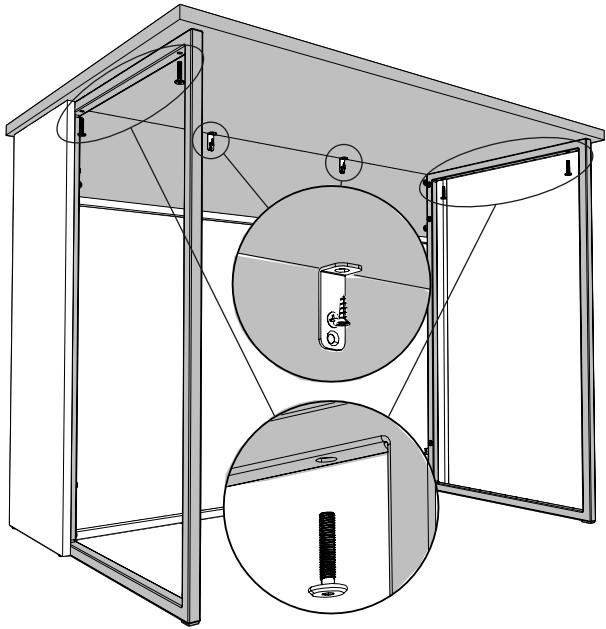
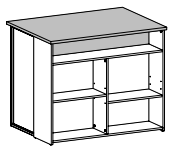
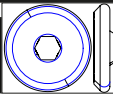

15 BWD
x8

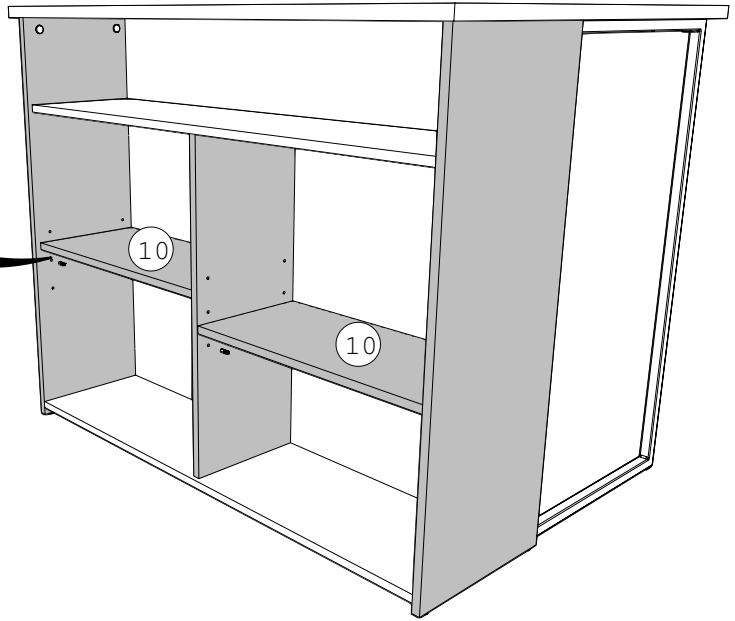
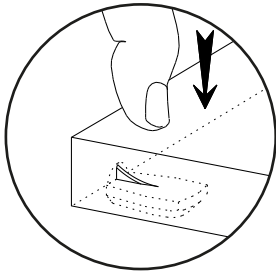
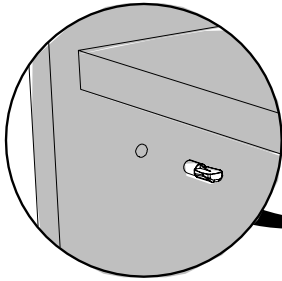
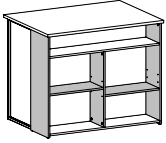

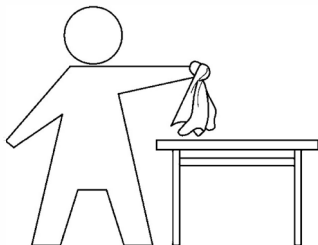

FR: INSTRUCTIONS GÉNÉRALES POUR LE MOBILIER CONSTITUÉ DE BOIS OU DE COMPOSITES DE BOIS (COMME LES SURFACES EN MELAMINÉ, STRATIFIÉ OU PLACAGE)

Nettoyer à l'aide d'un chiffon humide. Utiliser uniquement de l'eau ou un détergent doux.
Essuyer à l'aide d'un chiffon propre.

EN: GENERAL INSTRUCTION FOR FURNITURE MADE OF WOOD OR WOOD COMPOSITES SUCH AS MELAMINE, LAMINATE OR VENEER SURFACES!

Wipe clean with a damp cloth. Use only water or a gentle detergent.
Wipe dry with a clean cloth.

DE: ALLGEMEINE ANWEISUNGEN FÜR MÖBELPFLEGE AUS HOLZ ODER HOLZVERBUNDWERKSTOFFEN (WIE MELAMIN-, LAMINAT- ODER FURNIEROBERFLÄCHEN)

Mit einem feuchten Tuch reinigen. Verwenden Sie nur Wasser oder ein mildes Reinigungsmittel.
Mit einem sauberen Tuch abwischen.

HU: ÁLTALÁNOS ÚTMUTATÁS A FÁBÓL KÉSZÜLT VAGY ÖSSZETETT FAANYAGOT, PÉLDÁUL MELAMIN-, LAMINÁLT VAGY FURNÉRFELÜLETET TARTALMAZÓ BÚTOROKHOZ

Törölje tisztára nedves ruhával. Csak vizet vagy kímélő tisztítószeret használjon.
Törölje szárazra tiszta ruhával.

PT: INSTRUÇÕES GERAIS PARA OS MOVÉIS DE MADEIRA, LAMINADO, MELAMINA E FOLHEADO.

Limpar com um pano húmido, utilizar apenas água ou detergente doce.
Limpar com um pano seco

IT: ISTRUZIONI GENERALI PER MOBILI IN LEGNO O MATERIALI COMPOSITI IN LEGNO (COME SUPERFICI IN MELAMINICO, LAMINATO O IMPIALLACCIATO)

Pulire con un panno umido. Utilizzare solo acqua o un detergente delicato.
Asciugare con un panno pulito.

NL: ALGEMENE INSTRUCTIES VOOR MEUBELS VERVAARDIGD UIT HOUT OF HOUTCOMPOSITIET ALS MELAMINE, LAMINAAT OF FINEEROPPERVLAKKEN!

Reinig met een vochtige doek. Gebruik alleen water of wasmiddel
Droogwrijven met een schone doek

CZ: OBECNÉ POKYNY TÝKAJÍCÍ SE NÁBYTKU VYROBENÉHO ZE DŘEVA NEBO Z KOMPOZITŮ DŘEVA, NAPŘ. S POUŽITÍM MELAMINU, LAMINÁTU NEBO DÝHY!

Čistěte otřením navlhčeným hadříkem. Používejte pouze vodu nebo jemný čistící prostředek.
Vytrěte dosucha čistým hadříkem.

ES: INSTRUCCIONES GENERALES PARA MUEBLES FABRICADOS CON MADERA, MELAMINA, LAMINADO Y CHAPA.

Limpiar con paño húmedo. Utilizar únicamente agua o detergente suave.
Secar con un paño seco .

PL: OGÓLNE INSTRUKCJE DOTYCZĄCE MEBLI Z DREWNA ORAZ MATERIAŁÓW DREWNOPOCHODNYCH: MELAMINA, LAMINAT, OKLEINA

Do czyszczenia należy używać wilgotnej ściereczki. Używać wyłącznie wody lub delikatnego detergentu.
Wycierać do sucha ściereczką.

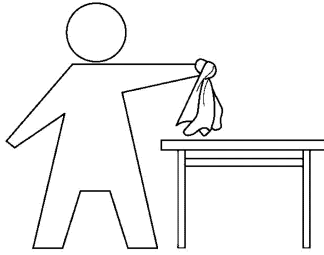

RO: INSTRUCȚIUNI GENERALE PENTRU PIESELE DE MOBILIER REALIZATE DIN LEMN SAU DIN COMPUȘI DIN LEMN PRECUM SUPRAFEȚELE MELAMINATE, LAMINATE SAU FURNIRUITE!

Curățați prin ștergere cu o lavetă umedă. Utilizați numai apă sau un detergent delicat. Uscați prin ștergere cu o lavetă curată.

RU: ОБЩИЕ УКАЗАНИЯ ОТНОСИТЕЛЬНО МЕБЕЛИ, ИЗГОТОВЛЕННОЙ ИЗ ДЕРЕВА ИЛИ ДРЕВЕСНЫХ КОМПОЗИЦИОННЫХ МАТЕРИАЛОВ, ТАКИХ КАК МЕЛАМИН, ЛАМИНАТ ИЛИ ШПОН!

Очистите изделие чистой влажной тканью. Используйте мягкодействующее моющее средство. Вытрите досуха чистой тряпкой.

SK: VŠEOBECNÉ POKYNY PRE NÁBYTOK VYROBENÝ Z DREVA ALEBO KOMPOZITNÝCH MATERIÁLOV, NAPRIKLAD MELAMÍNU, LAMINÁTU ALEBO PREGLEJKOVÝCH POVRCHOV!

Utrite dočista navlhčenou utierkou. Používajte iba vodu alebo jemný čistiaci prostriedok. Utrite dosucha čistou utierkou.

SL: SPLOŠNA NAVODILA ZA VZDRŽEVANJE POHIŠTVA IZ LESA ALI LESENIH KOMPOZITOV, KOT SO MELANIN, LAMINAT ALI FURNIR!

Obrišite z vlažno krpo. Uporablajte le vodo ali blag detergent. Posušite s čisto krpo.

TR: AHŞAP VEYA MELAMİN, LAMİNAT YA DA AHŞAP KAPLAMA GİBİ AHŞAP TÜREVİ YÜZEYLERDEN YAPILAN MOBİLYALARA YÖNELİK GENEL YÖNERGE!

Nemli bir bezle silerek temizleyin. Yalnızca su veya yumuşak bir deterjan kullanın. Temiz bir bezle silerek kurulaşın.

ZH: 针对实木及实木复合类（三聚氰胺面、层板、胶合板）家具的一般说明

请用湿布擦拭。只使用水或温和洗涤剂。
请用干净的布擦干。

AR: يجات عامة للأثاث المصنوع من الخشب أو الخشب (مثل الأسطح المصنوعة من الميلامين أو إيفاندي أو القشرة). تنظيف بقعة قماش مبللة. ستخدم الماء فقط أو منطاف معتدى بمسح قطعة قماش نضيف



**LE TRI
+ FACILE**



FR

**Pensez à
donner ou recycler.**



Association

ou



Magasin

ou



Déchèterie

<https://quefairedemesdechets.fr>