

# MONTAGEANLEITUNG

Artikelnummer: WF318640/WF318641

Dieses Set ist in 2 Boxen enthalten. Wenn Sie keine vollen 2 Boxen erhalten, wenden Sie sich bitte an unseren Kundenservice

## Kinderbett 200x90cm

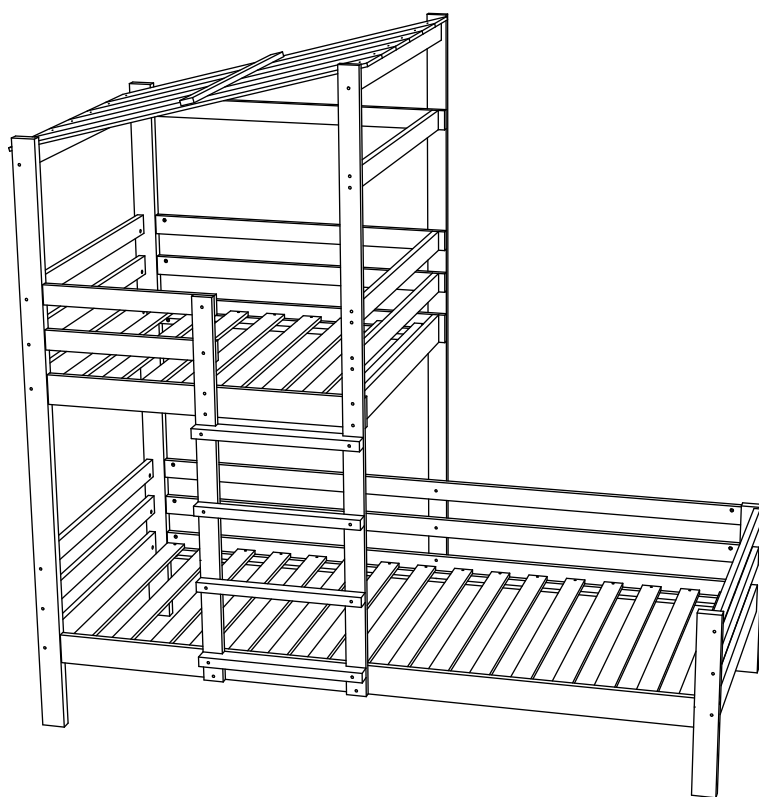

**D** Gebrauchsanweisung

**NL** Gebruiksrichtlijnen

**IT** Istruzioni per l'uso

**CZ** Pokyny k použití

**HU** Használati útmutató

**PT** Instruções de utilização

**SK** Pokyny k použitiu

**GB** Instructions for use

**FR** Instructions d'utilisation

**PL** Instrukcja obsługi

**ES** Instrucciones de empleo

**RO** Instrucțiuni de folosire

**RU** Инструкция по монтажу

**TR** Kullanım talimatları

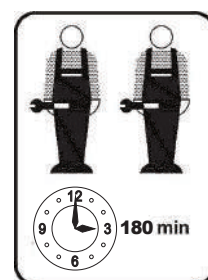

**FR - Notice de montage / EN - Assembly instructions / PT - Instruções de montagem /  
ES - Prospecto de montaje / DE - Montageanleitung / IT - Istruzioni di montaggio /  
NL - Montagehandleiding**

**FR - IMPORTANT! CONSERVER POUR CONSULTATION ULTERIEURE: LIRE ATTENTIVEMENT**

- A monter par un adulte. Un adulte doit vérifier le bon assemblage avant l'emploi
- ATTENTION! tenir les vis et petits éléments et sachets hors de portée des enfants
- Bien identifier les éléments avant de commencer le montage
- Ne pas utiliser votre article lorsque l'un de ses éléments est cassé ou manquant
- En cas de problème contactez notre service après-vente
- Toujours suivre les instructions du fabricant
- Entretien: nettoyer avec un chiffon doux et sec. En cas de taches plus grosses, frottez soigneusement avec une éponge légèrement humide et non abrasive
- Ne pas sauter sur le lit

**EN - IMPORTANT! KEEP FOR FUTURE REFERENCE: READ CAREFULLY**

- To be assembled by an adult. Assembly must be checked by an adult before use
- WARNING! keep all screws, small parts and plastic bags out of the reach of children
- Properly identify all parts before assembling
- Never use your item if any of its parts are broken or missing
- Should any problems arise, please contact our After Sales Service
- Manufacturer's instructions shall be followed at all times
- Care: clean with a soft, dry cloth. In case of larger stains, carefully rub with a slightly damp, non-abrasive sponge
- Do not jump on the bed

**PT - IMPORTANTE! GARDE PARA CONSULTA POSTERIOR: LER ESTAS INSTRUÇÕES CUIDADOSAMENTE**

- A ser montado por um adulto. Um adulto deve verificar a boa montagem antes da utilização
- Atenção! mantenha os parafusos, acessórios pequenos e saco de plástico fora do alcance das crianças
- Identifique bem os acessórios antes de começar a montagem
- Não utilizar o artigo se um dos elementos está em falta ou danificado
- Para qualquer esclarecimento, contacte os nossos serviços através do telefone
- As instruções do fabricante devem ser sempre cumpridas
- Manutenção: limpe com um pano macio e seco. Em caso de manchas maiores, esfregue cuidadosamente com uma esponja ligeiramente húmida e não abrasiva
- Não salte na cama

**ES - IMPORTANTE! CONSERVAR PARA FUTURAS CONSULTAS: LEER DETENIDAMENTE**

- A montar por un adulto. Un adulto debe comprobar el buen montaje antes de la utilización
- ¡ADVERTENCIA! mantener los tornillos, los pequeños elementos y bolsitas fuera del alcance de los niños
- Identificar debidamente los elementos antes de empezar el montaje
- No utilizar este artículo si uno de los elementos falta o esta roto
- Si tiene problemas, contactar nuestro servicio postventa
- Deben seguirse siempre las instrucciones del fabricante Cuidados: limpiar con un paño suave y seco. En caso de manchas grandes, frotar con cuidado utilizando una esponja húmeda no abrasiva
- No saltar sobre la cama

**DE - WICHTIG! FÜR SPÄTERE BEZUGNAHME AUFBEWAHREN: SORGFÄLTIG LESEN**

- Von einem Erwachsenen zu montieren. Die korrekte Montage muss vor Gebrauch von einem Erwachsenen geprüft werden
- Achtung! die Schrauben und kleinen Teile ausserhalb der Reichweite von Kindern lagern
- Vor Montagebeginn alle Teile identifizieren
- Ihren Artikel nicht benutzen, wenn eines seiner Bestandteile beschädigt ist oder fehlt
- Im Problemfall Ihren Kundendienst anrufen
- Stets die Herstelleranweisungen beachten
- Wartung: Mit einem weichen, trockenen Tuch reinigen. Bei größeren Flecken vorsichtig mit einem leicht feuchten, nicht scheuernden Schwamm abreiben
- Nicht auf dem Bett springen

**IT - IMPORTANTE! CONSERVARE QUESTE INFORMAZIONI PER ULTERIORI CONSULTAZIONI: LEGGI ATTENTAMENTE**

- Il montaggio deve essere eseguito da un adulto. Un adulto dovrà verificare il corretto montaggio prima dell'uso
- ATTENZIONE! tenere le viti ed i componenti di piccole dimensioni lontano dalla portata dei bambini
- Controllare i pezzi prima del montaggio
- L'articolo non deve essere utilizzato in caso di elementi mancanti o danneggiati
- In caso di necessità contattare il nostro servizio post-vendita
- Seguire sempre le istruzioni del costruttore
- Manutenzione: pulire con un panno morbido e asciutto. Per le macchine più grandi, strofinare accuratamente con una spugna leggermente umida e non abrasiva
- Non saltare sul letto





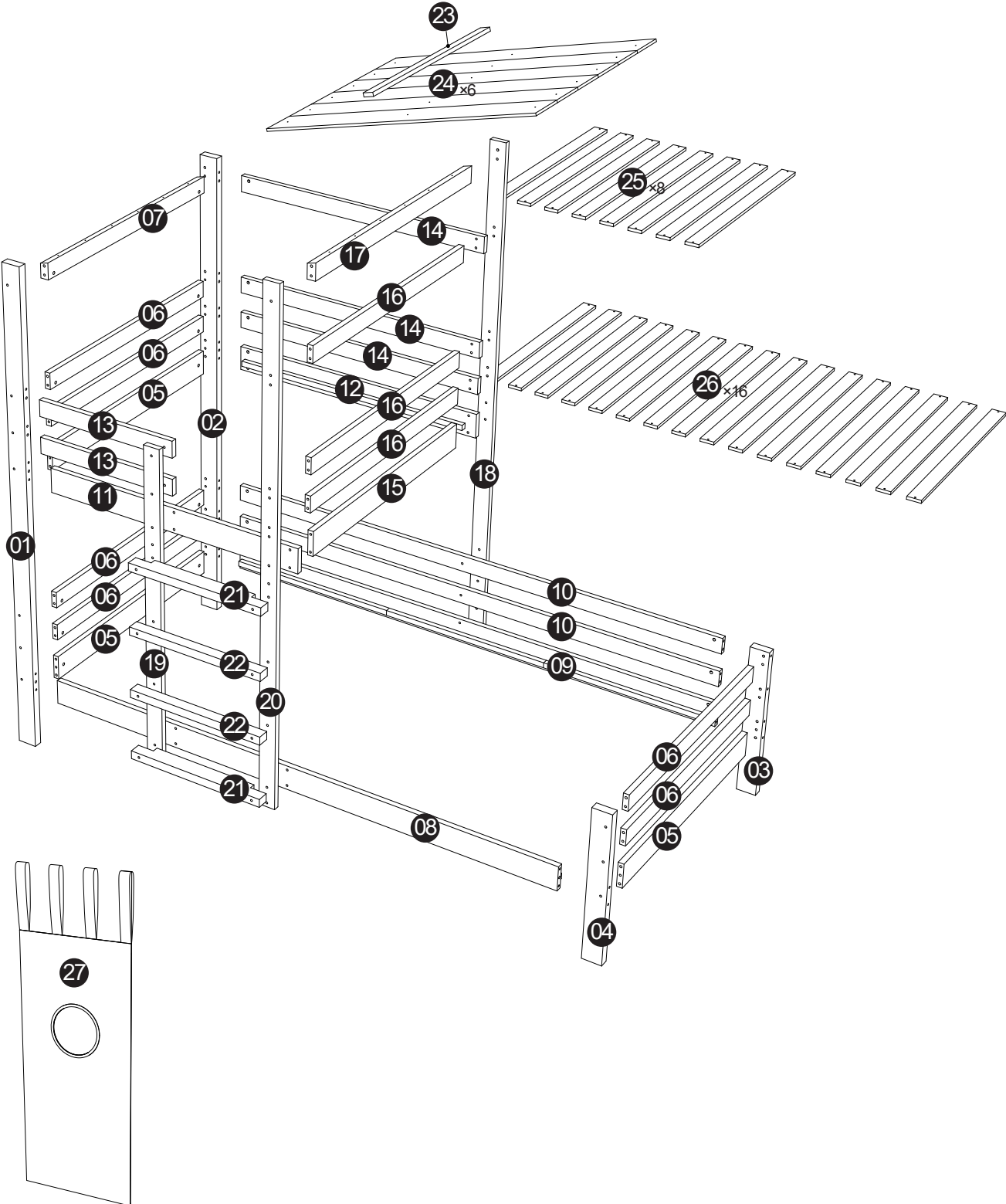

**NL - BELANGRIJK! BEWAAR VOOR LATERE RAADPLEGING: LEES AANDACHTIG**

- Moet door een volwassene worden gemonteerd. Voor gebruik moet een volwassene controleren dat het product goed in elkaar is gezet
- WAARSCHUWING! schroeven en kleine elementen en zakjes buiten bereik van kinderen houden
- De elementen goed identificeren alvorens met de montage te beginnen
- Uw artikel niet gebruiken wanneer een van de onderdelen kapot is of ontbreekt
- Neem bij problemen contact op met onze klantenservice
- Volg altijd de instructies van de fabrikant
- Onderhoud: maak schoon met een zachte en droge doek. In geval van grotere vlekken, veeg voorzichtig schoon met een licht bevochtigde en niet-schurende spons
- Niet springen op het bed

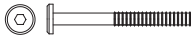
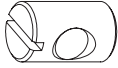
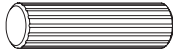
# Stückliste

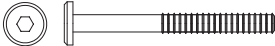
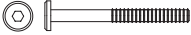
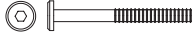
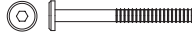

# WF318640

<p>A x22</p>  <p>M6x70</p>	<p>B x59</p> 	<p>C x42</p>  <p>Φ8x30</p>	<p>D x2</p> 
<p>E x21</p>  <p>M6x110</p>	<p>F x8</p>  <p>M6x60</p>	<p>G x10</p>  <p>M6x80</p>	<p>H x10</p>  <p>M6x30</p>
<p>I x18</p> 	<p>J x6</p>  <p>M6x50</p>	<p>K x18</p>  <p>Φ4x20</p>	<p>L x48</p>  <p>Φ4x30</p>

## Wichtiger Hinweis:

Bestätigen Sie bitte alle Komponenten und Schrauben vor der Montage. Bitte wenden Sie sich an uns, falls einige Teile oder Schrauben im Paket fehlt sind.



# WF318640

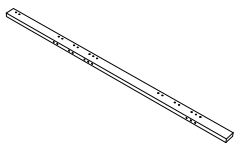
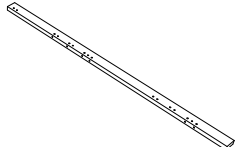
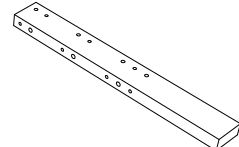
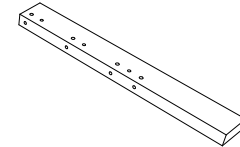
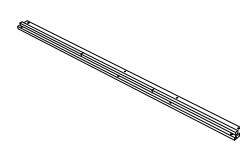
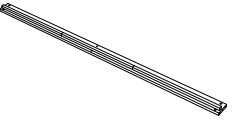
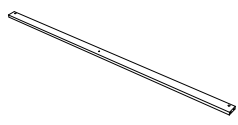
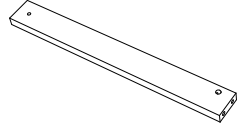
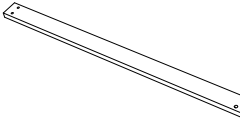
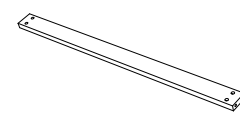
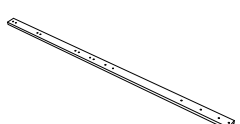
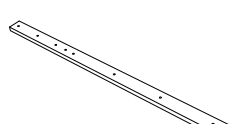
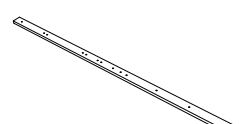
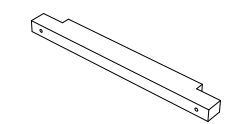
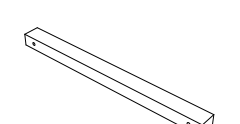
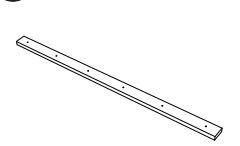
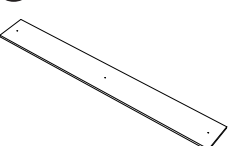

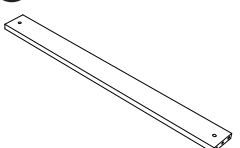
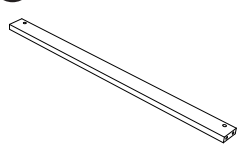
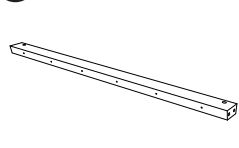
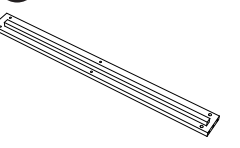
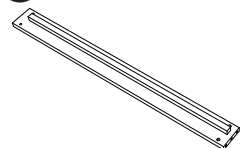
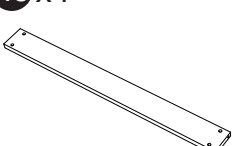
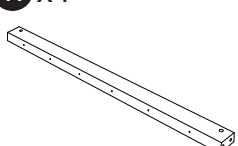
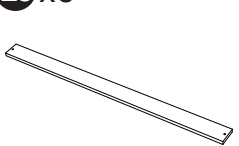
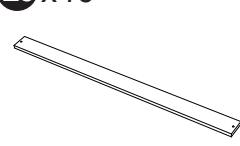
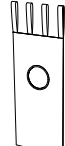

<b>01</b> x1 	<b>02</b> x1 	<b>03</b> x1 	<b>04</b> x1 	<b>08</b> x1 
<b>09</b> x1 	<b>10</b> x2 	<b>13</b> x2 	<b>14</b> x3 	<b>16</b> x3 
<b>18</b> x1 	<b>19</b> x1 	<b>20</b> x1 	<b>21</b> x2 	<b>22</b> x2 
<b>23</b> x1 	<b>24</b> x6 			

# WF318641

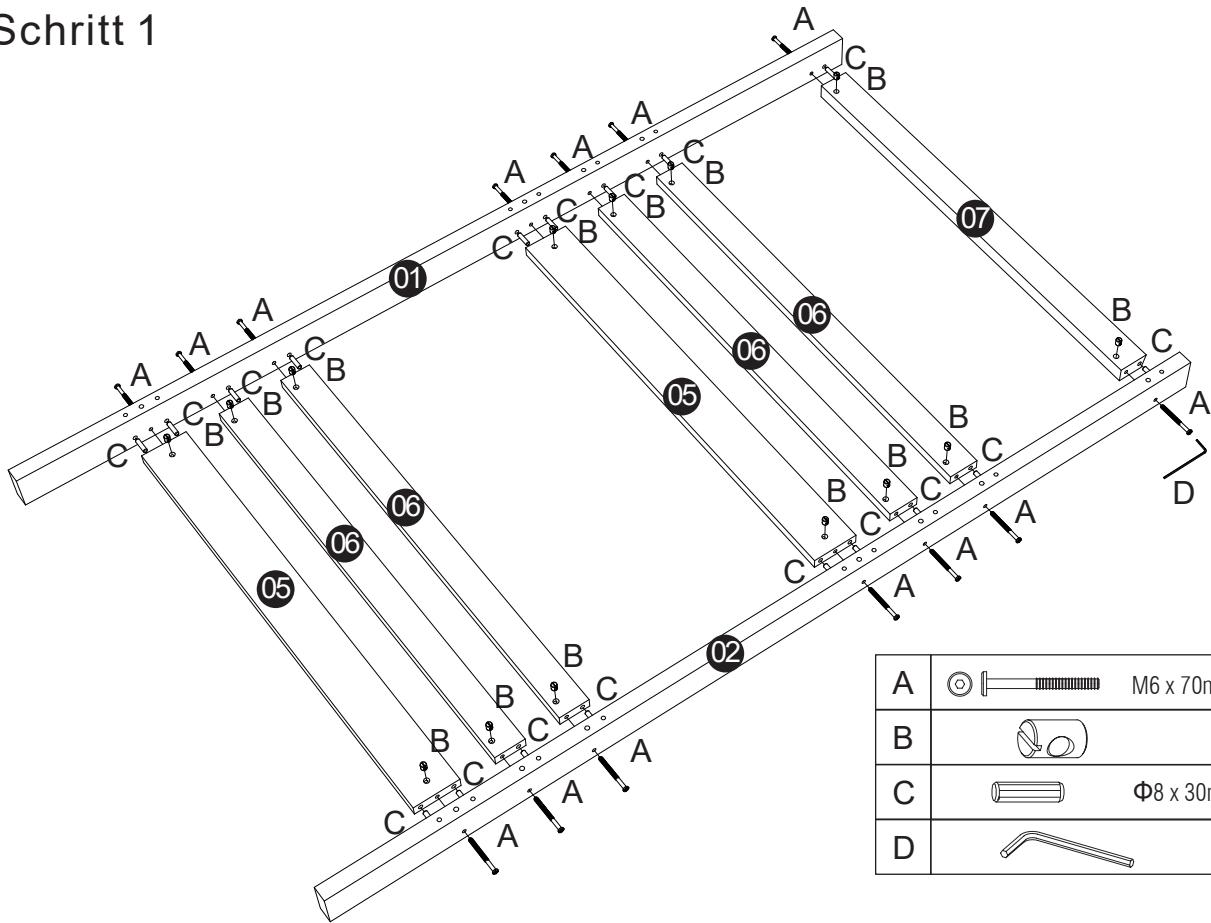
<b>05</b> x3 	<b>06</b> x6 	<b>07</b> x1 	<b>11</b> x1 	<b>12</b> x1 
<b>15</b> x1 	<b>17</b> x1 	<b>25</b> x8 	<b>26</b> x16 	<b>27</b> x1 





## Schritt 1

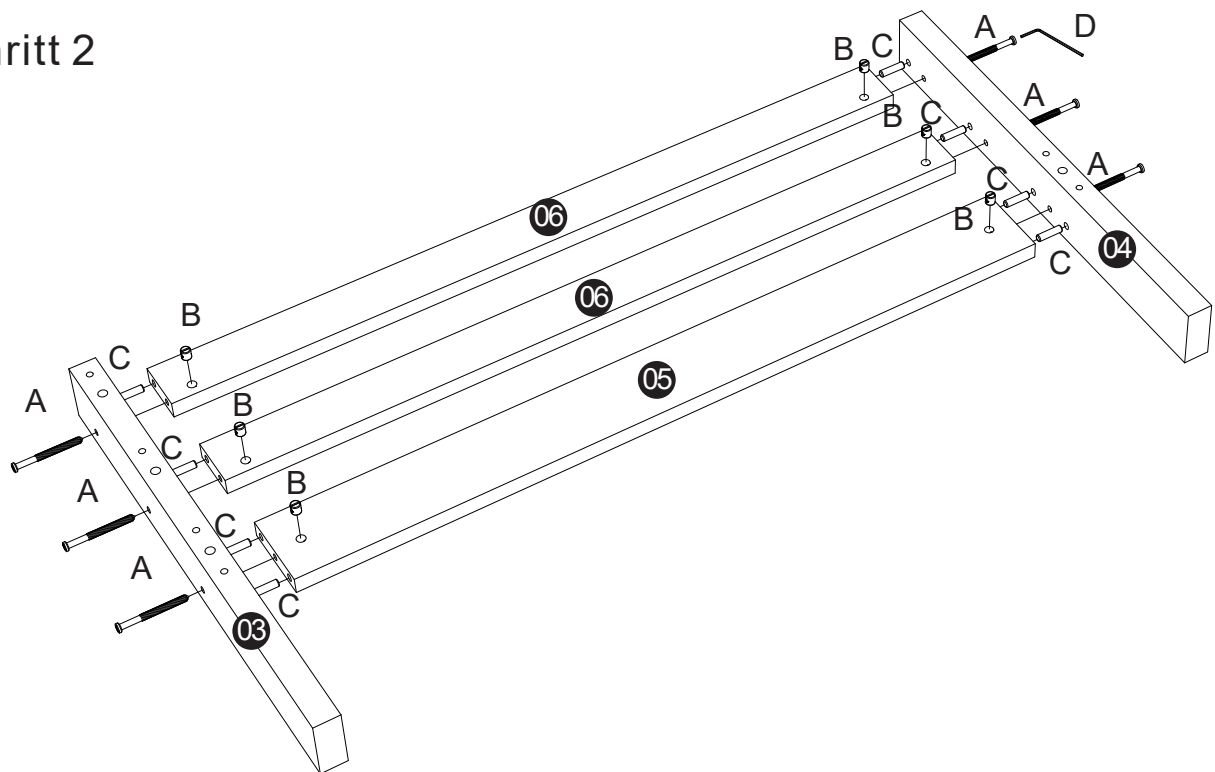

A		M6 x 70mm	14
B			14
C		Φ8 x 30mm	18
D			1





## Schritt 2

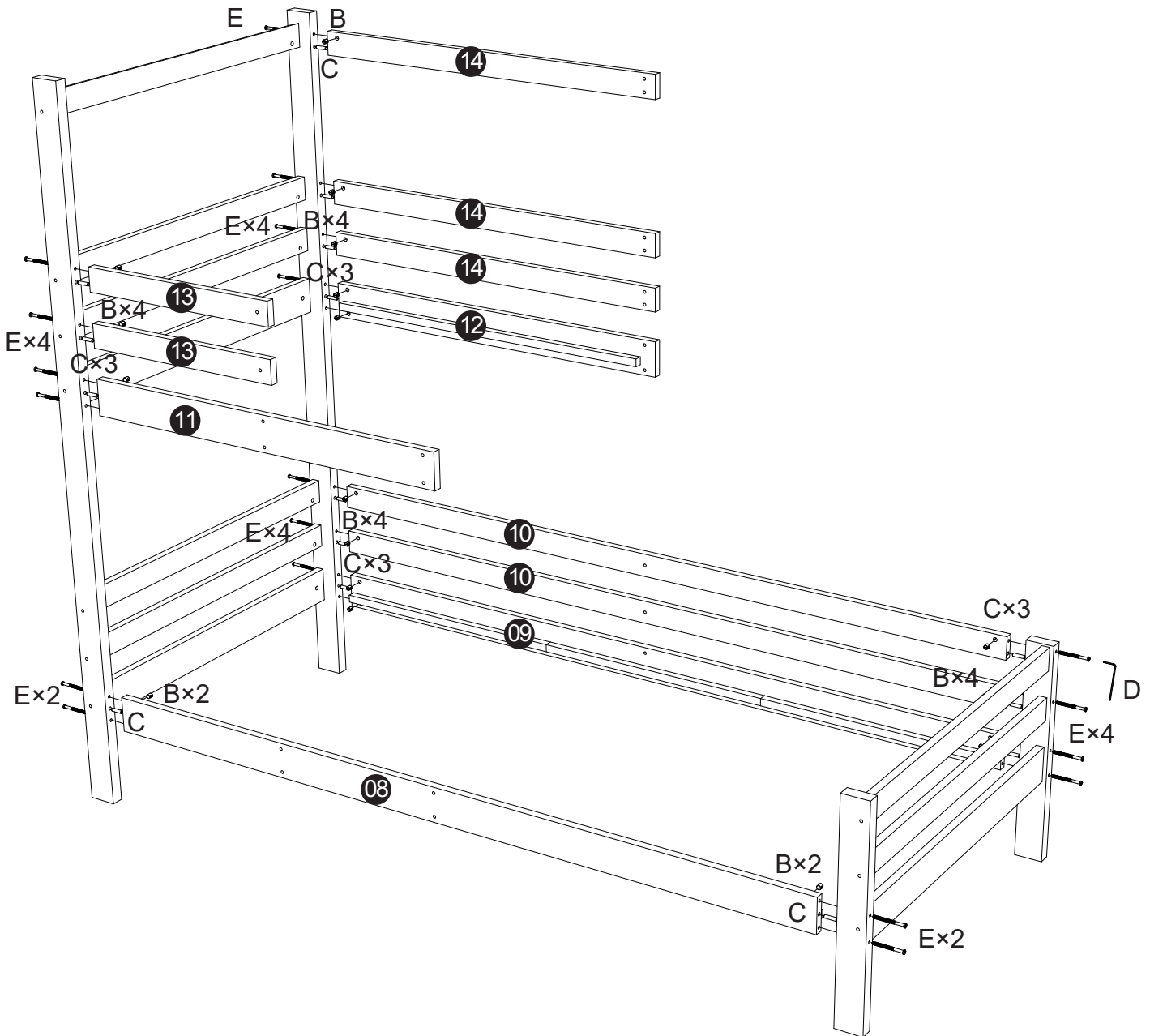

A		M6 x 70mm	6
B			6
C		Φ8 x 30mm	8
D			1

# Schritt 3







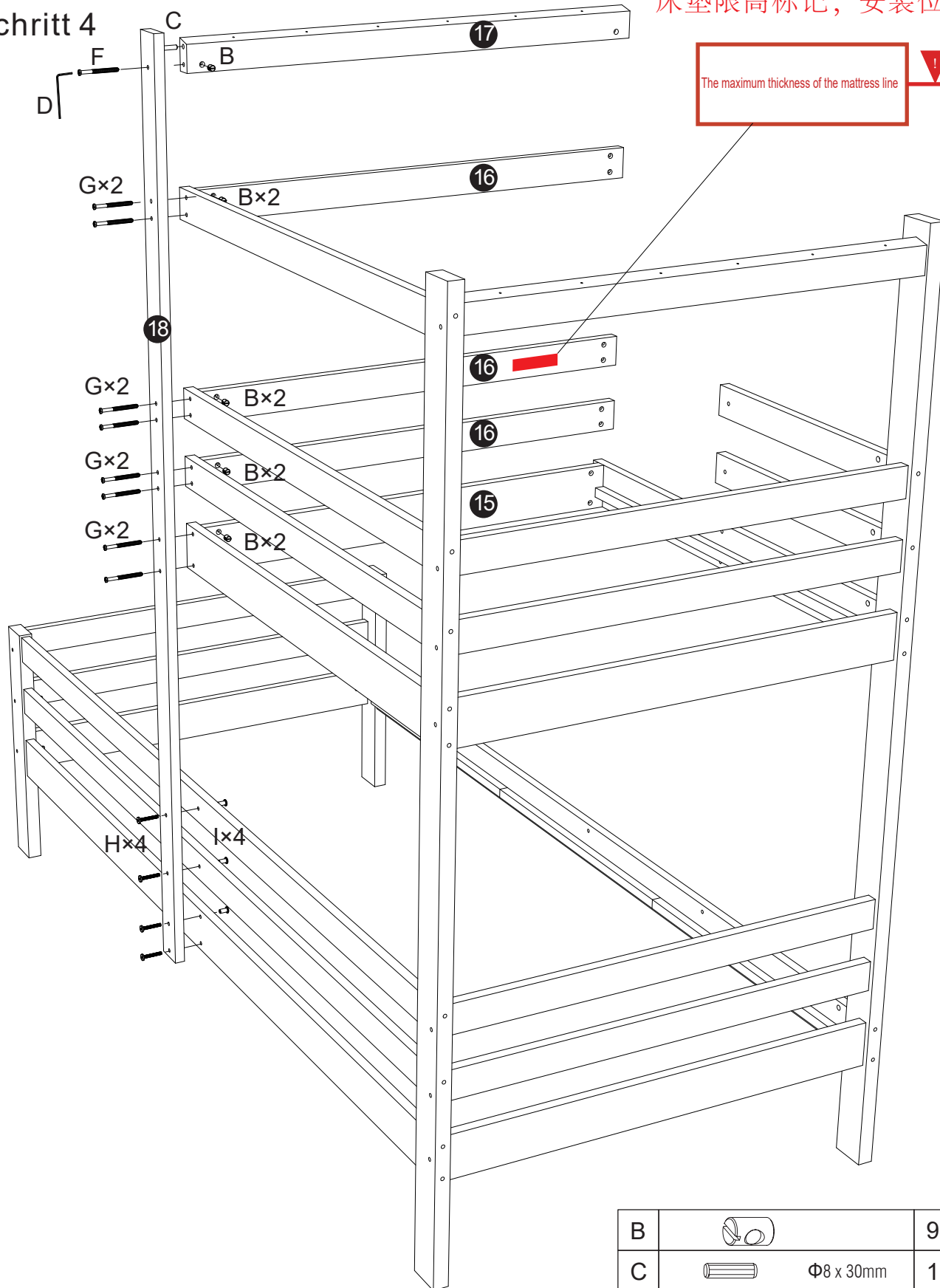

B			21
C		Φ8 x 30mm	15
D			1
E		M6 x 110mm	21

# Schritt 4

床垫限高标记，安装位置！



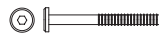
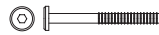



The maximum thickness of the mattress line

B		9
C	 $\Phi 8 \times 30\text{mm}$	1
D		1
F	 M6 x 60mm	1
G	 M6 x 80mm	8
H	 M6 x 30mm	4
I		4

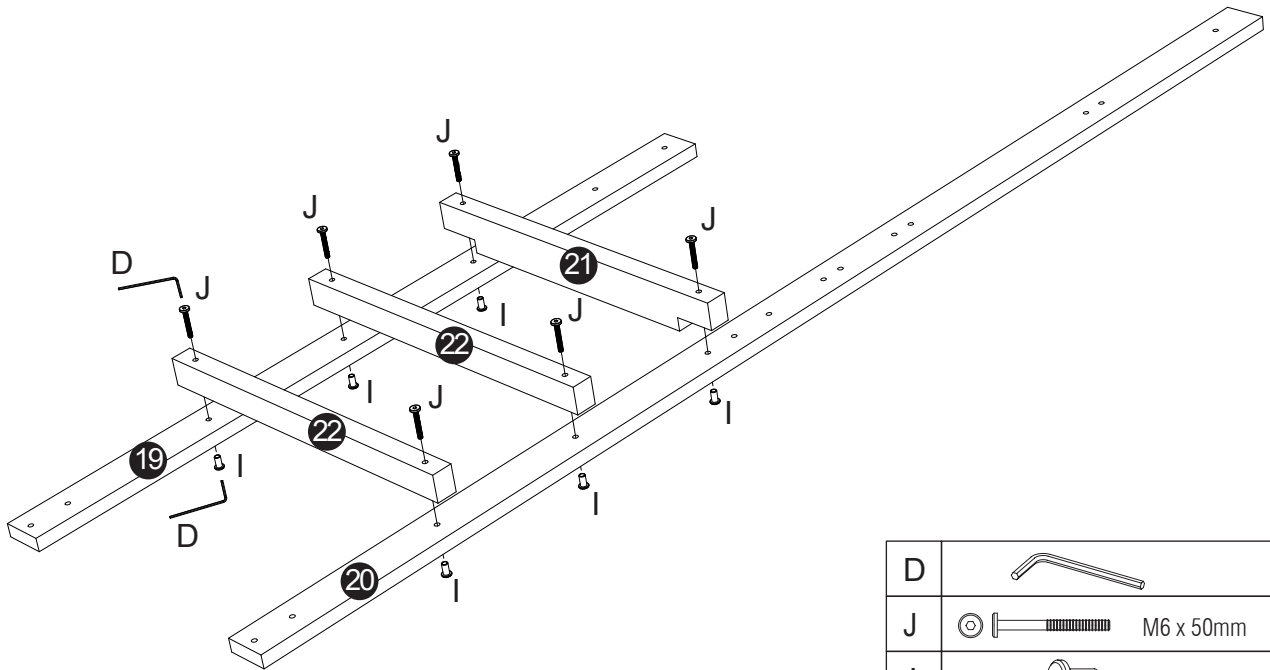

## Schritt 5







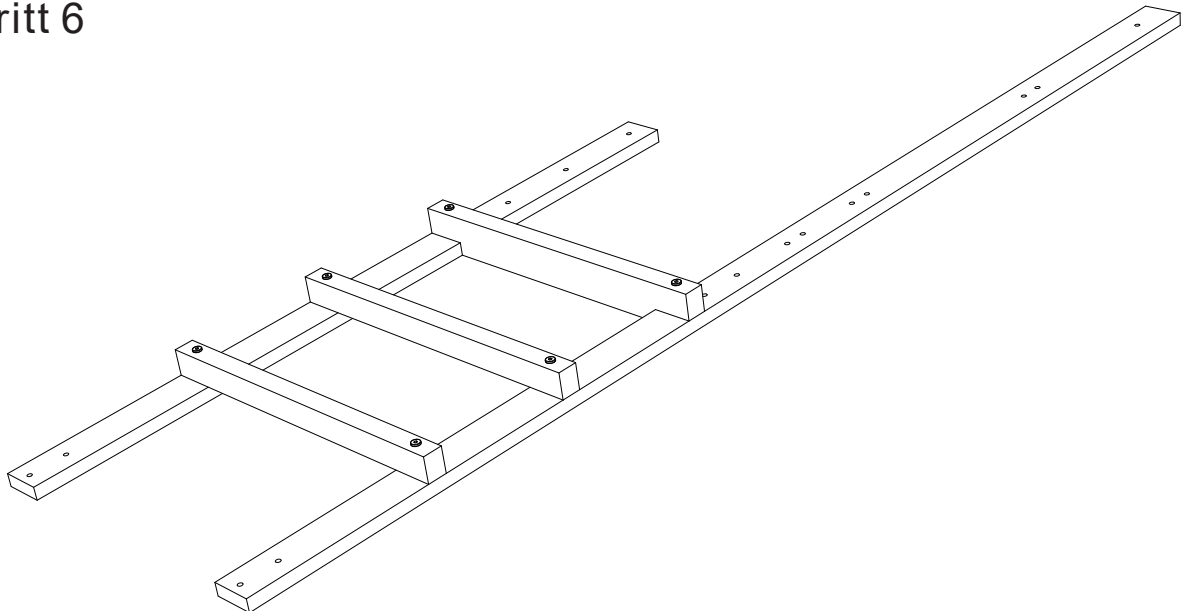

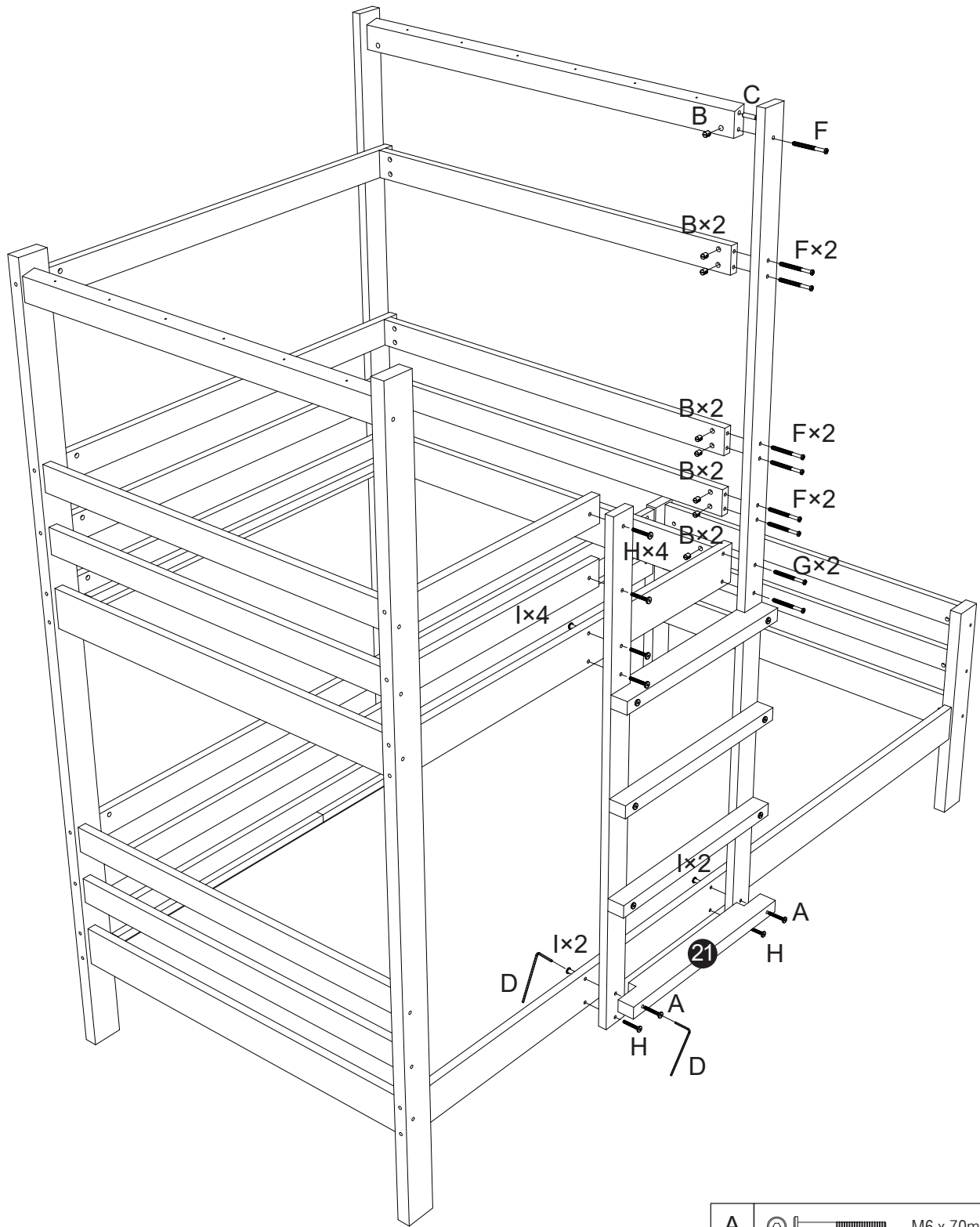

D		2
J	 M6 x 50mm	6
I		6

## Schritt 6





# Schritt 7

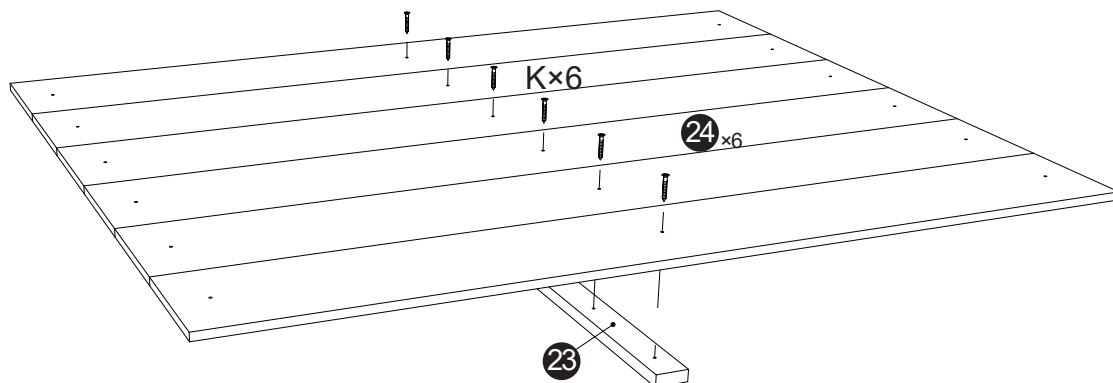

A		M6 x 70mm	2
B			9
D			2
F		M6 x 60mm	7
G		M6 x 80mm	2
H		M6 x 30mm	6
I			8

## Schritt 8



K		Φ4x20mm	6
---	---	---------	---

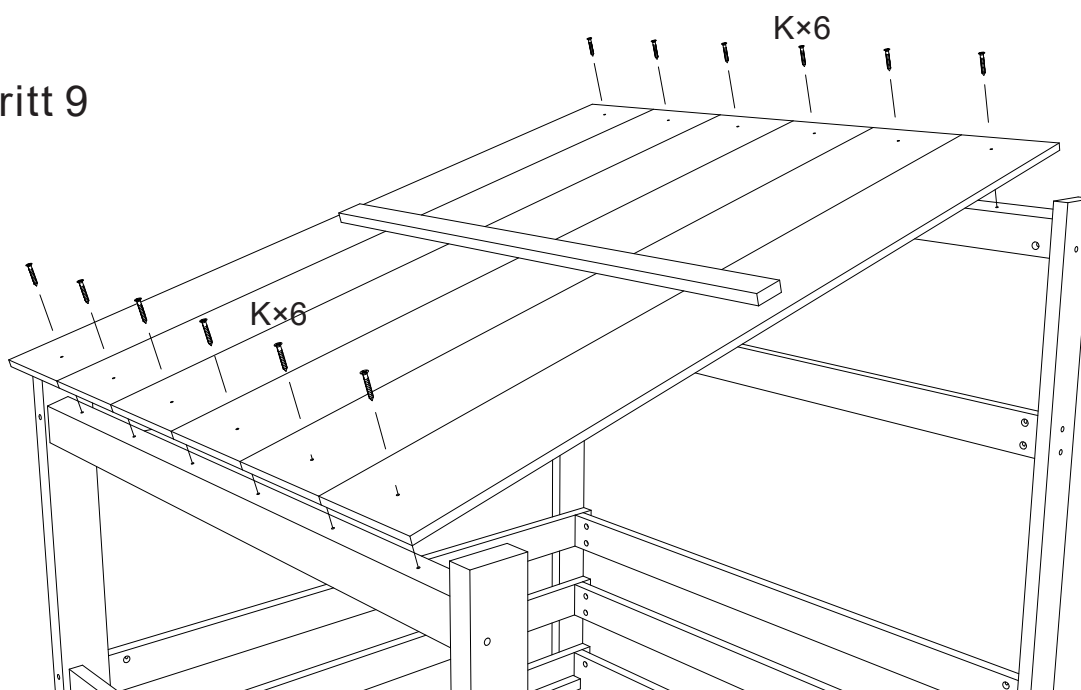

## Schritt 9

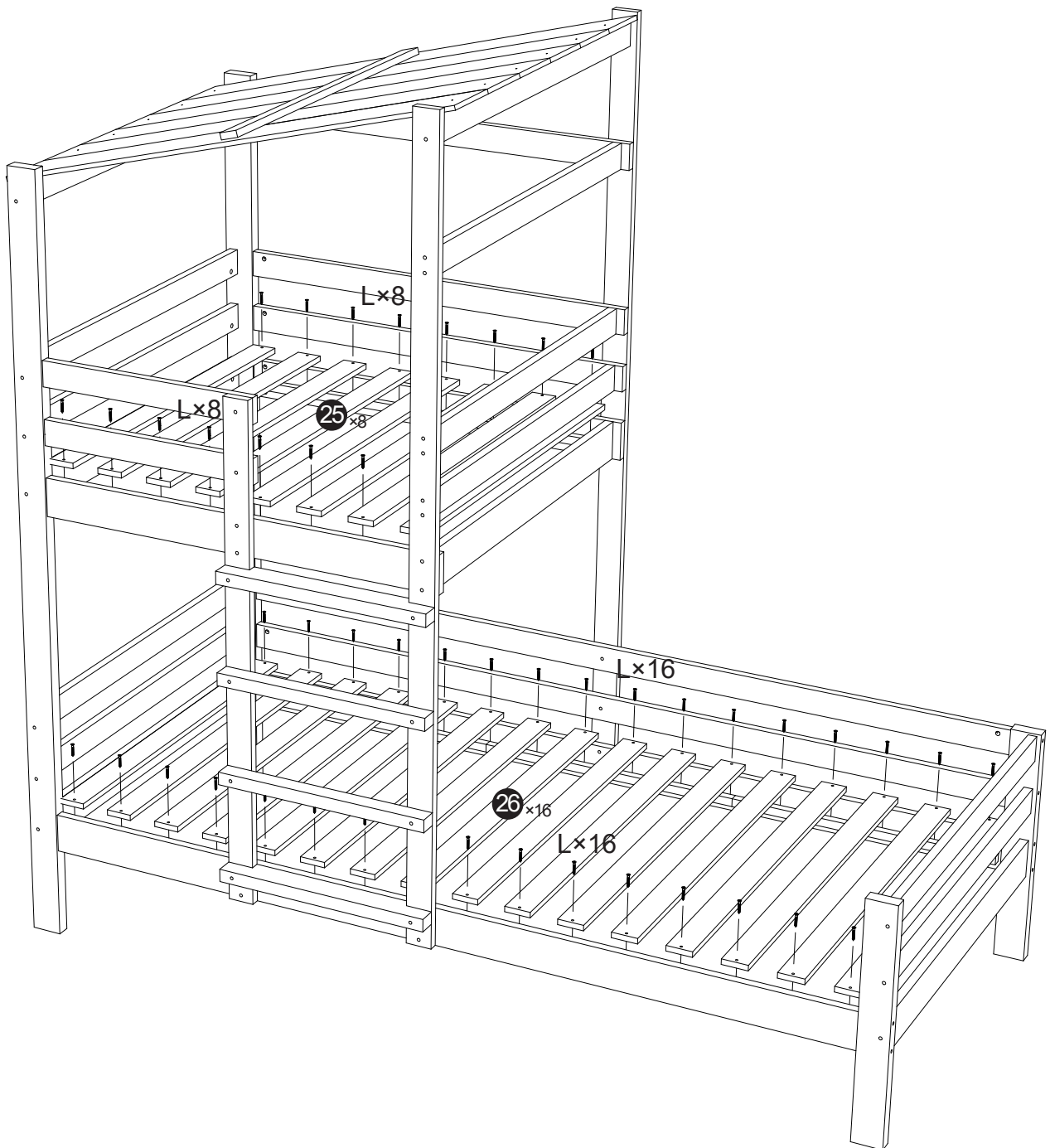

K		Φ4x20mm	12
---	---	---------	----

# Schritt 10



L			Φ4x30mm	48
---	---	---	---------	----

## Schritt 11

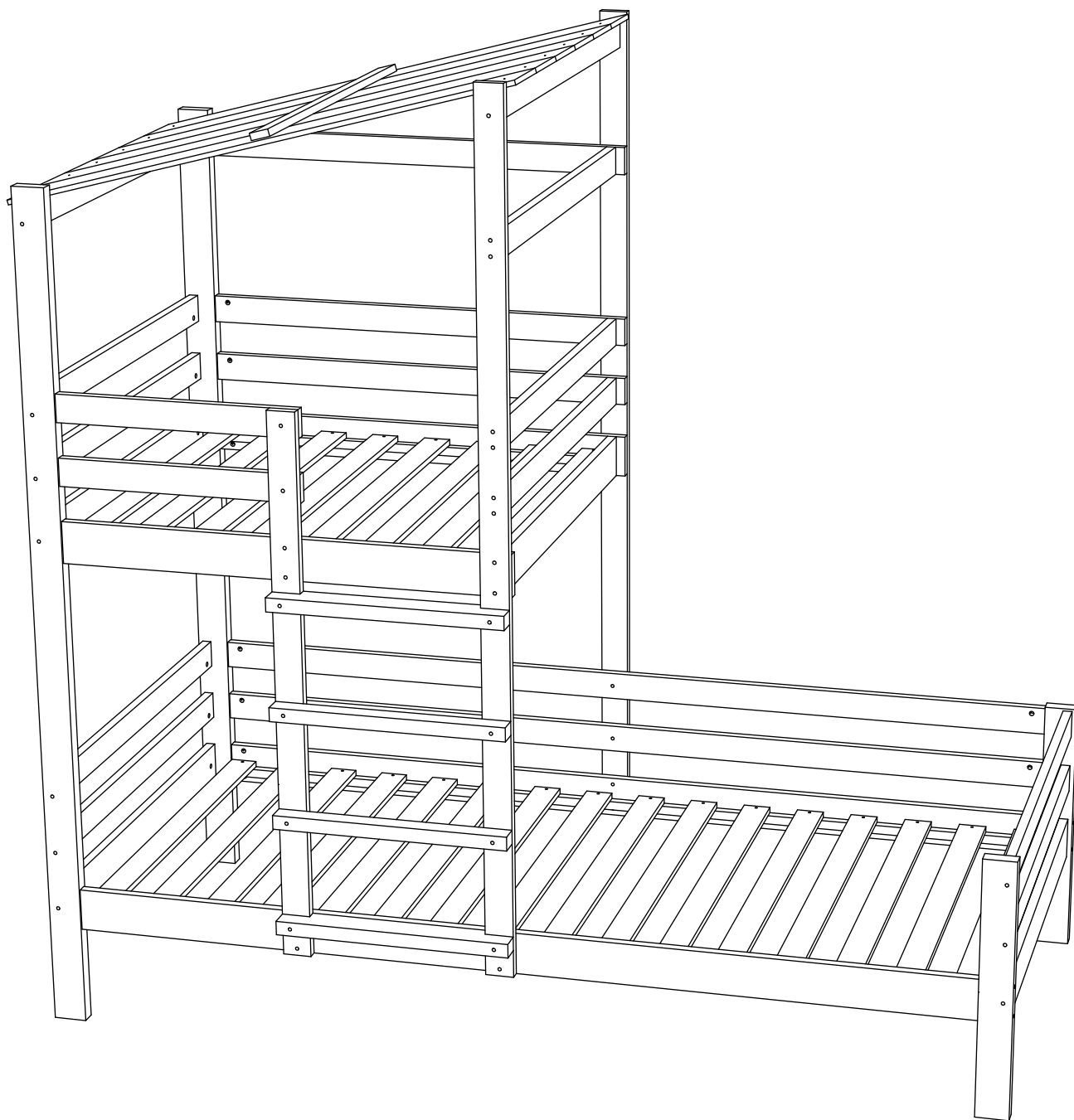

# Schritt 12

