

87147

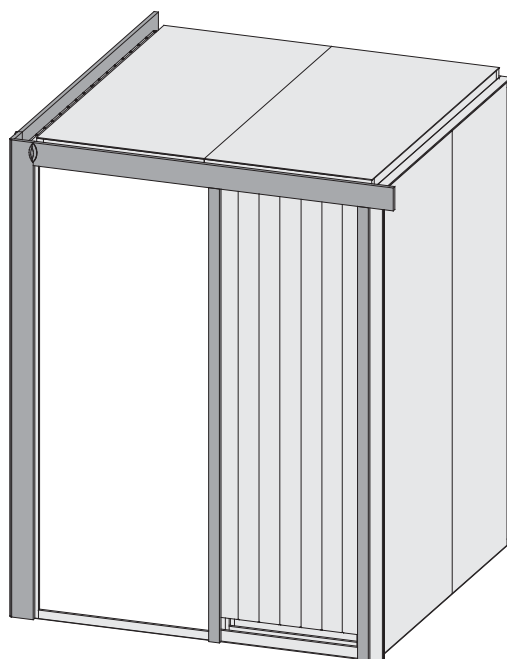

-  **Aufbauanleitung**
-  **Building Instructions**
-  **notice de montage**
-  **montagehandleiding**
-  **Montagevejledning**
-  **Instrucciones de construcción**
-  **Istruzioni per il montaggio**
-  **Montážní návod**

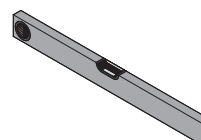

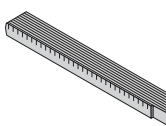
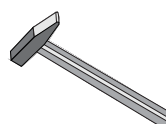
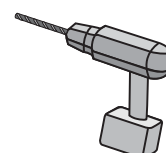
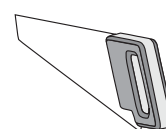

Vergleichen Sie zuerst die Material-liste mit Ihrem Paketinhalt! Bitte haben Sie Verständnis, dass Beanstandungen nur im nicht aufgebauten Zustand bearbeitet werden können!



Vergelijk eerst de lijst van materialen met de inhoud van uw pakket! Reclamaties kunnen alleen in behandeling worden genomen zolang de onderdelen nog niet zijn gemonteerd!



Confrontate questa distinta materiali prima con il contenuto del pacchetto! Vi preghiamo di comprendere che eventuali reclami possono essere accolti solo prima del montaggio!



First compare the list of materials with your package contents! Please understand that complaints can be processed in the non-built status only!



Start med at kontrollere materialelisten med indholdet af den leverede pakke! Vi gør venligst opmærksom på at reklamationer kun kan behandles for materialer som ikke er blevet bearbejdet!



Nejprve přezkontrolujte obsah balení podle materiálového listu! Mějte pochopení pro to, že případnou reklamaci se můžeme zabývat pouze tehdy, když díly nebudou smontované! Za pomoci tohoto seznamu můžete jednotlivé díly přiřadit k montážnímu návodu.



Commencez par comparer la liste du matériel avec le contenu de votre paquet! Sachez que nous traitons uniquement les réclamations concernant le matériel à l'état non monté!



En primer lugar, compare la lista de material con el contenido del paquete. Rogamos entienda que las reclamaciones sólo pueden ser tramitadas antes de montar el objeto!

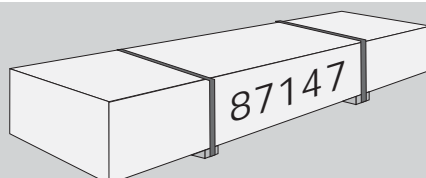

1 x W1	1920 x	606 x	68 mm	ID 25548
1 x W2	1920 x	780 x	68 mm	ID 25549

1 x W3	1920 x	606 x	68 mm	ID 25550

1 x W4	1920 x	606 x	57 mm	ID 23624
2 x W5	1920 x	780 x	57 mm	ID 23625

1 x W6	1920 x	606 x	57 mm	ID 23629

<div style="display: flex; align-items: center;"> <div style="margin-right: 10px;"> Siehe Türpaket Opmerking Door Package Note Door Package Remarque Package porte Nota Paquete Puerta Nota Door Package Poznámka Door balíček </div> </div>				
1 x W7				

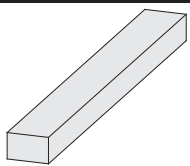

4 x B1	1920 x 19 x 3 mm	ID 20799
4 x B2	750 x 36 x 12 mm	ID 24239
4 x B3	1920 x 36 x 12 mm	ID 24846
4 x B4	1884 x 45 x 17 mm	ID 48037
4 x B5	70 x 45 x 18 mm	ID 26366
4 x B6	800 x 45 x 18 mm	ID 24796
4 x B7	480 x 95 x 18 mm	ID 20930
4 x B8	580 x 95 x 18 mm	ID 16708
2 x B9	1505 x 95 x 18 mm	ID 26398
1 x B10	300 x 120 x 18 mm	ID 22467
2 x B11	551 x 42 x 28 mm	ID 24053
2 x B12	880 x 42 x 28 mm	ID 81170
2 x B13	1326 x 42 x 28 mm	ID 24108
2 x B14	1382 x 42 x 28 mm	ID 24107
4 x B15	1408 x 42 x 28 mm	ID 26354
4 x B16	1492 x 42 x 28 mm	ID 26397
3 x B17	1874 x 52 x 52 mm	ID 26165

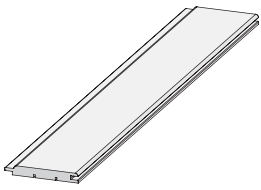

2 x E1	1920 x 97 x 12 mm	ID 22863
--------	-------------------	----------

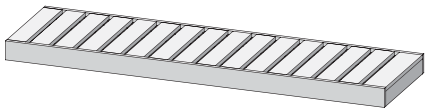

2 x L1	1377 x 500 x 90 mm	ID 25542
--------	--------------------	----------

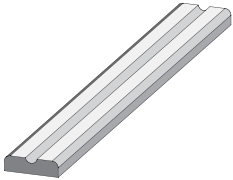

2 x F1	1377 x 90 x 22 mm	ID 26727
--------	-------------------	----------

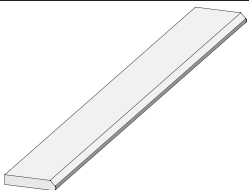

2 x G1	1980 x 95 x 17 mm	ID 48540
--------	-------------------	----------

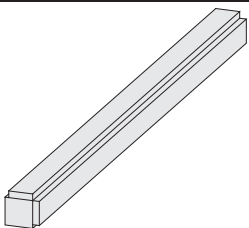

1 x K1	1874 x 64 x 64 mm	ID 24725
--------	-------------------	----------



2 x M1	1406 x 700 x 57 mm	ID 24801
--------	--------------------	----------

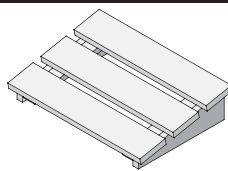

1 x		ID 20708
-----	--	----------

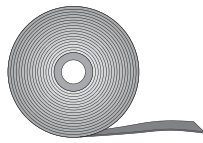

10m		ID 14025
-----	--	----------

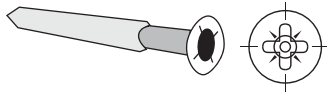

50 x	4,5 x 40 mm	ID 26285
------	-------------	----------

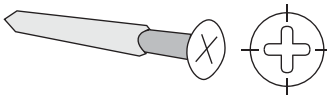

45 x	4 x 30 mm	ID 3686
35 x	4 x 50 mm	ID 3688
35 x	4 x 70 mm	ID 3689
40 x	4,5 x 80 mm	ID 9204
20 x	6 x 60 mm	ID 14014

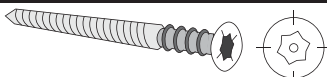

6 x S1		ID 14266
--------	--	----------



6 x	3 x 16mm	ID 46376
-----	----------	----------

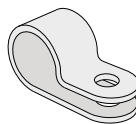

1 x		ID 50420
-----	--	----------

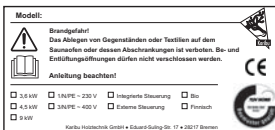

1 x		
-----	--	--



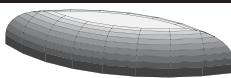

50 x S2	4,5 x 30 mm	ID 26116
6 x S3	12 x 18 mm	ID 46403



4 x T1		ID 26272
--------	--	----------

-  Übersicht
-  Overview
-  enquête

-  overzicht
-  undersøgelse
-  estudio

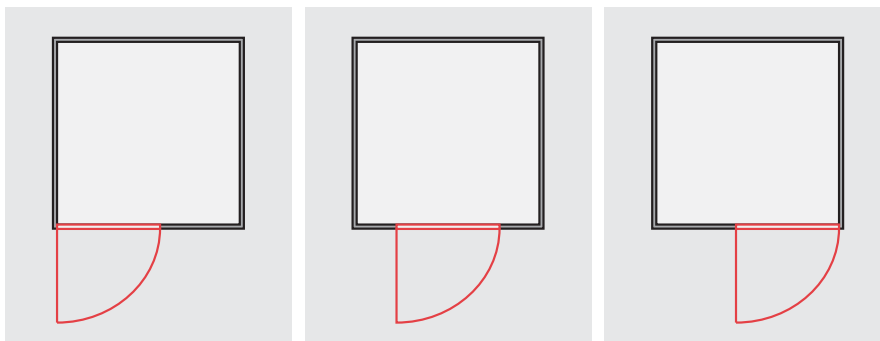
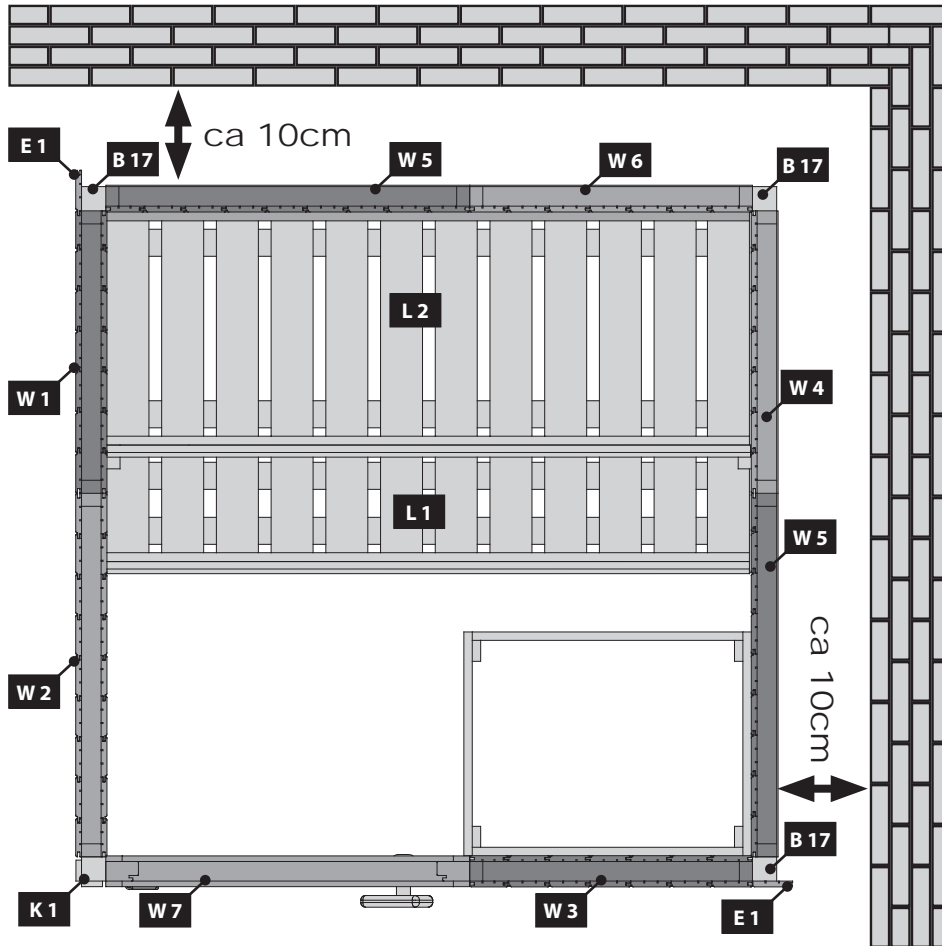

-  sondaggio
-  přehled



-  Einbau Tür
-  Installation door
-  Porte d'installation
-  Installatie deur
-  Installationsdør
-  Puerta de instalación
-  Porta di installazione
-  Montážní dveře

 Übersicht
 Overview
 enquête

 overzicht
 undersøgelse
 estudio

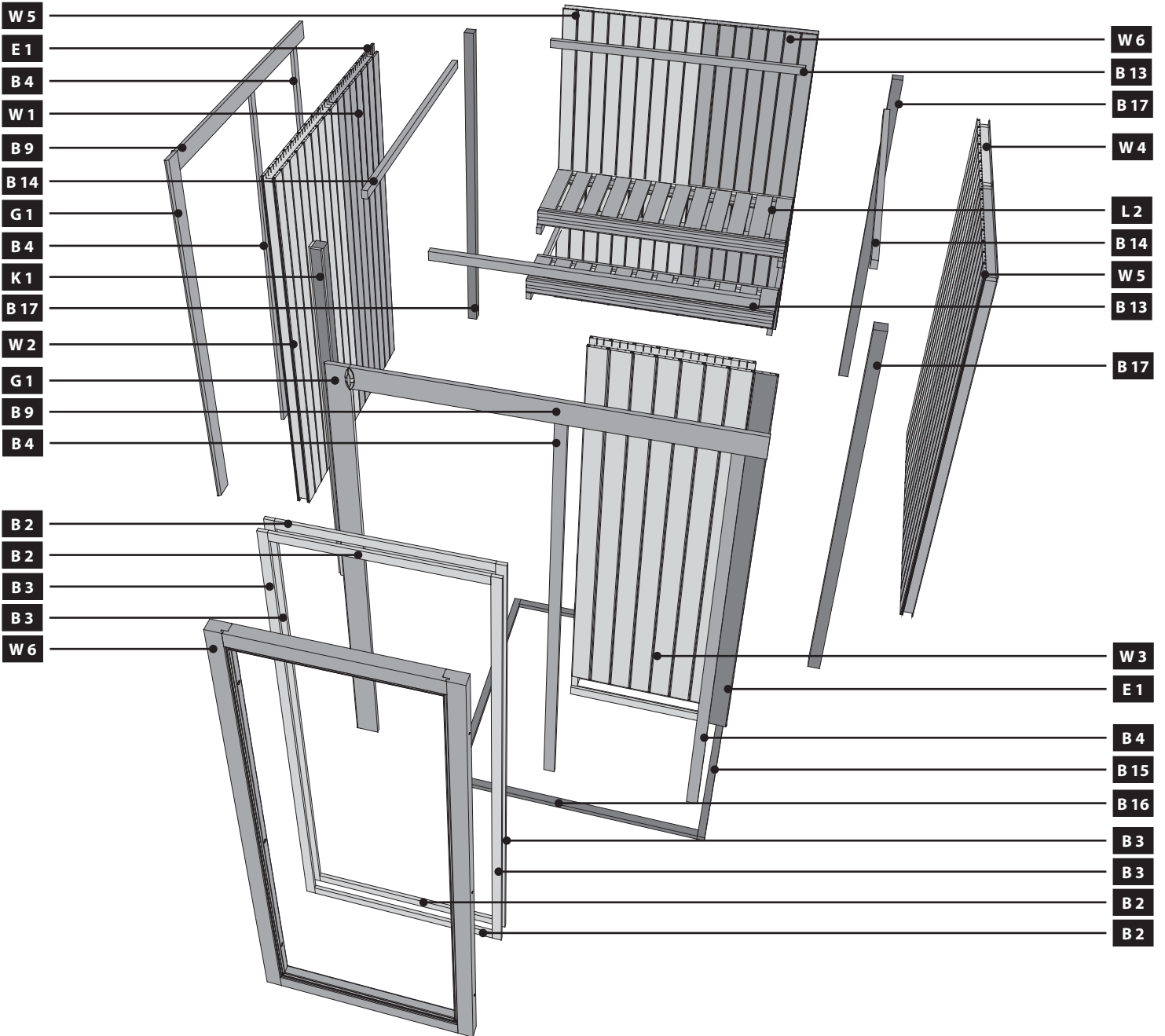
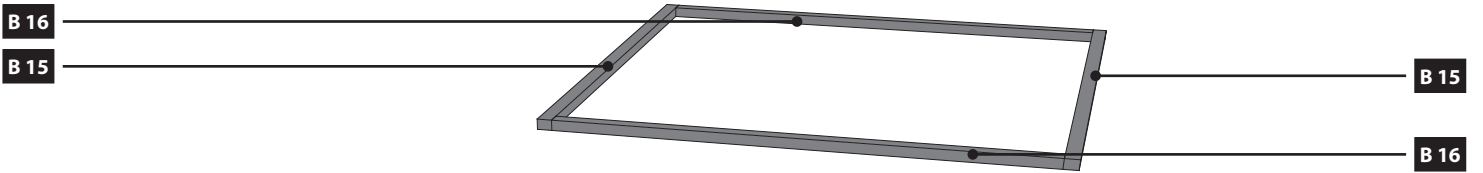

 sondaggio
 přehled

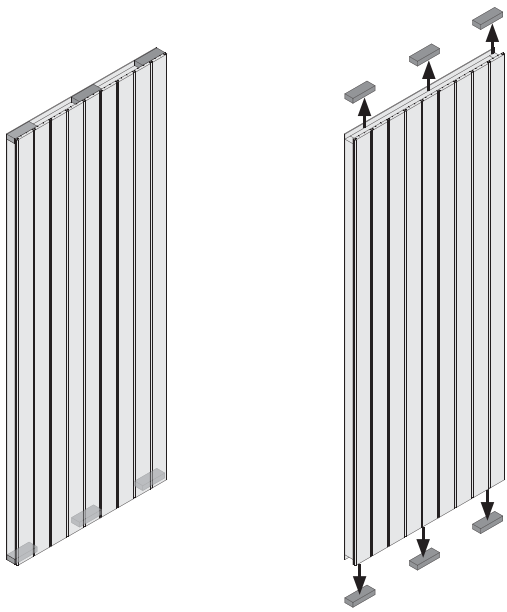

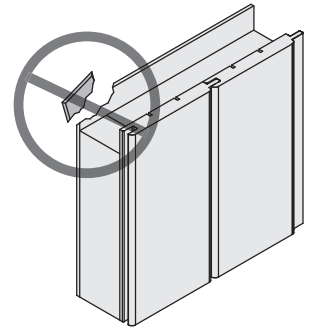

-  Vorsicht!
-  Attention!
-  Attention!
-  Voorzichtig!
-  Forsigtig!
-  Cuidado!
-  Occhio!
-  Pozor!



Ø3 mm  4x70
8x 

01

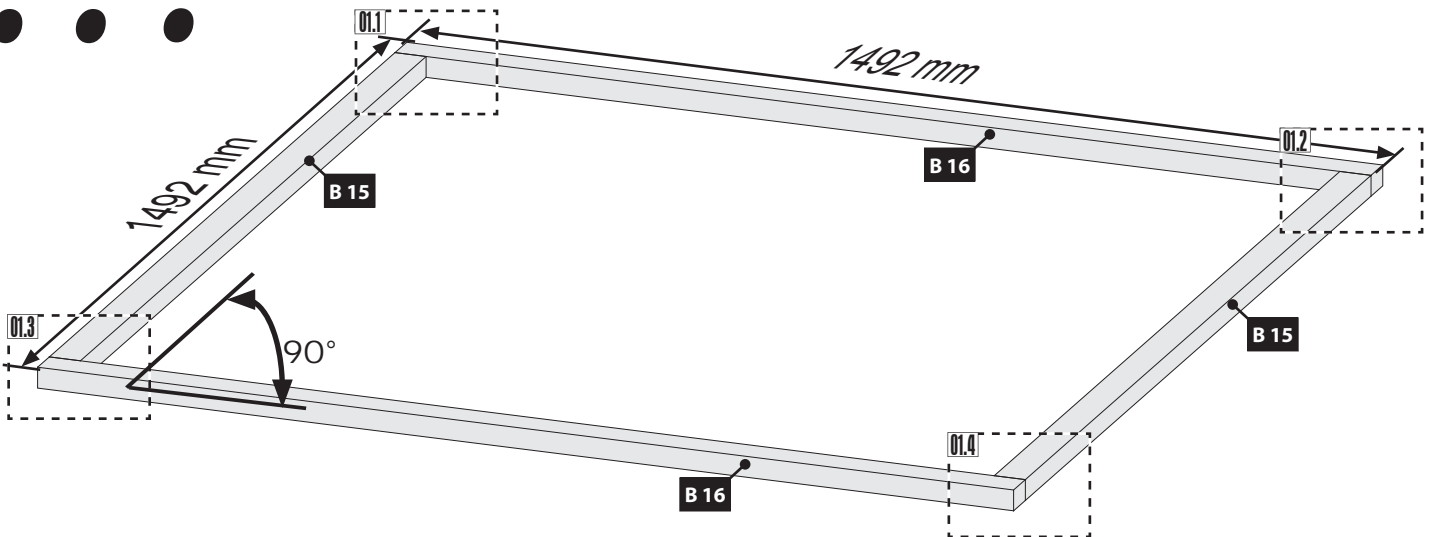

01.1

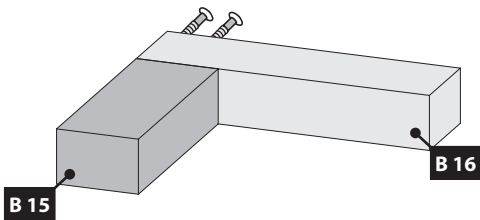

01.2

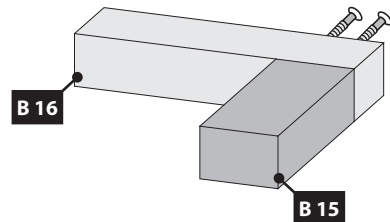

01.3

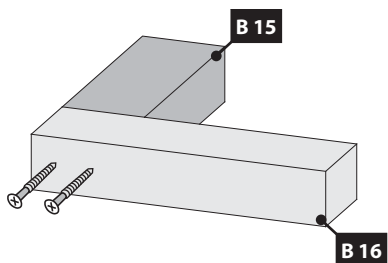

01.4

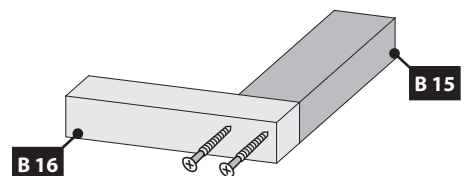

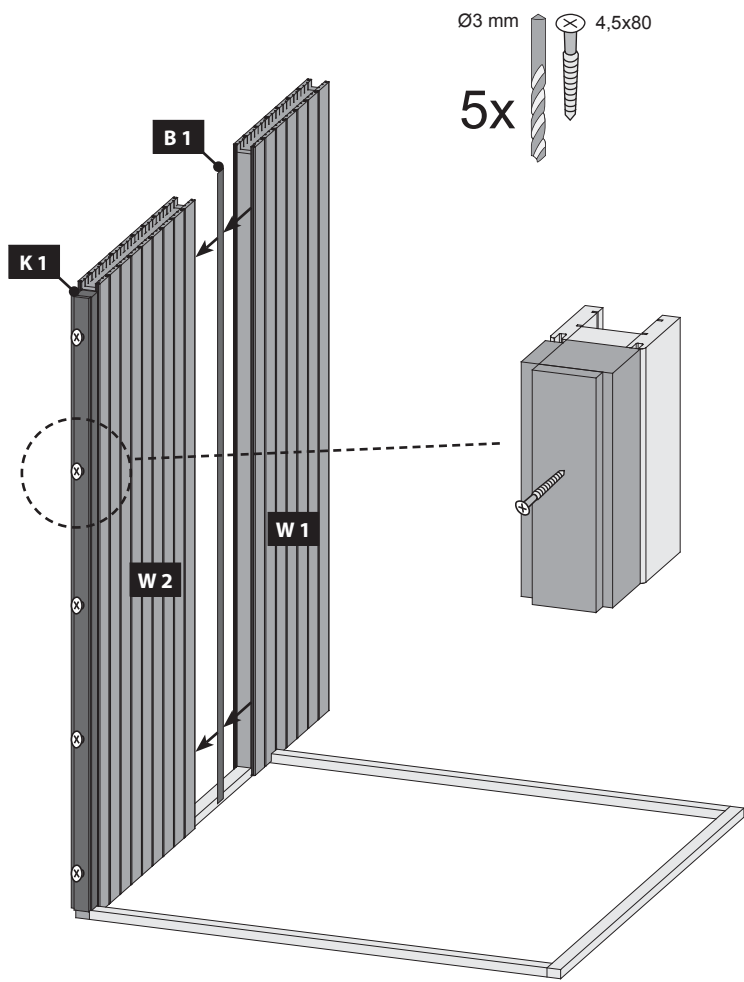
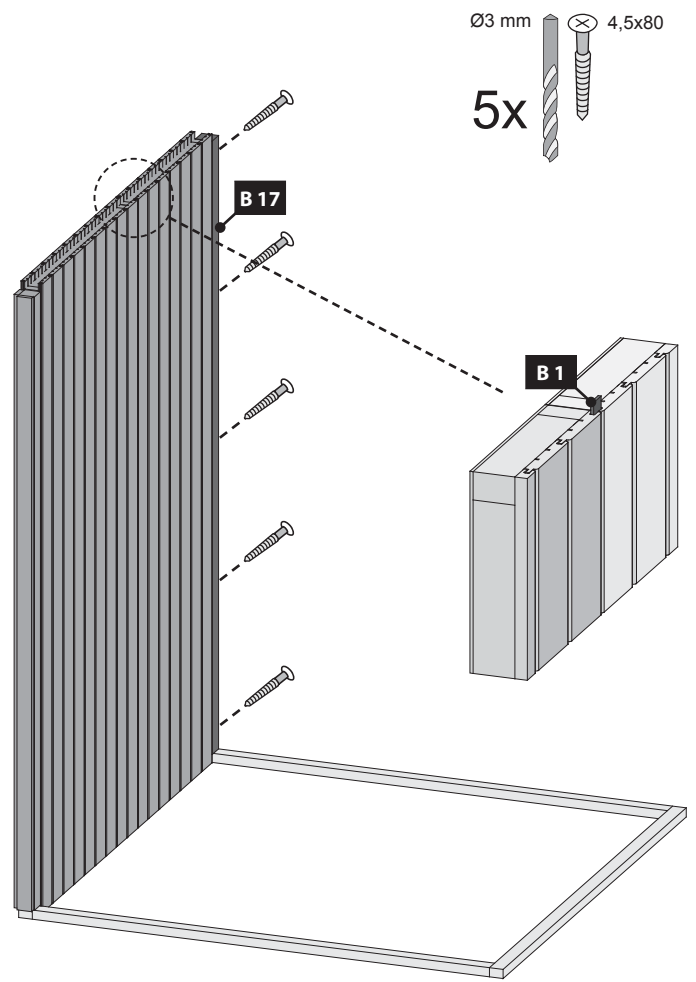
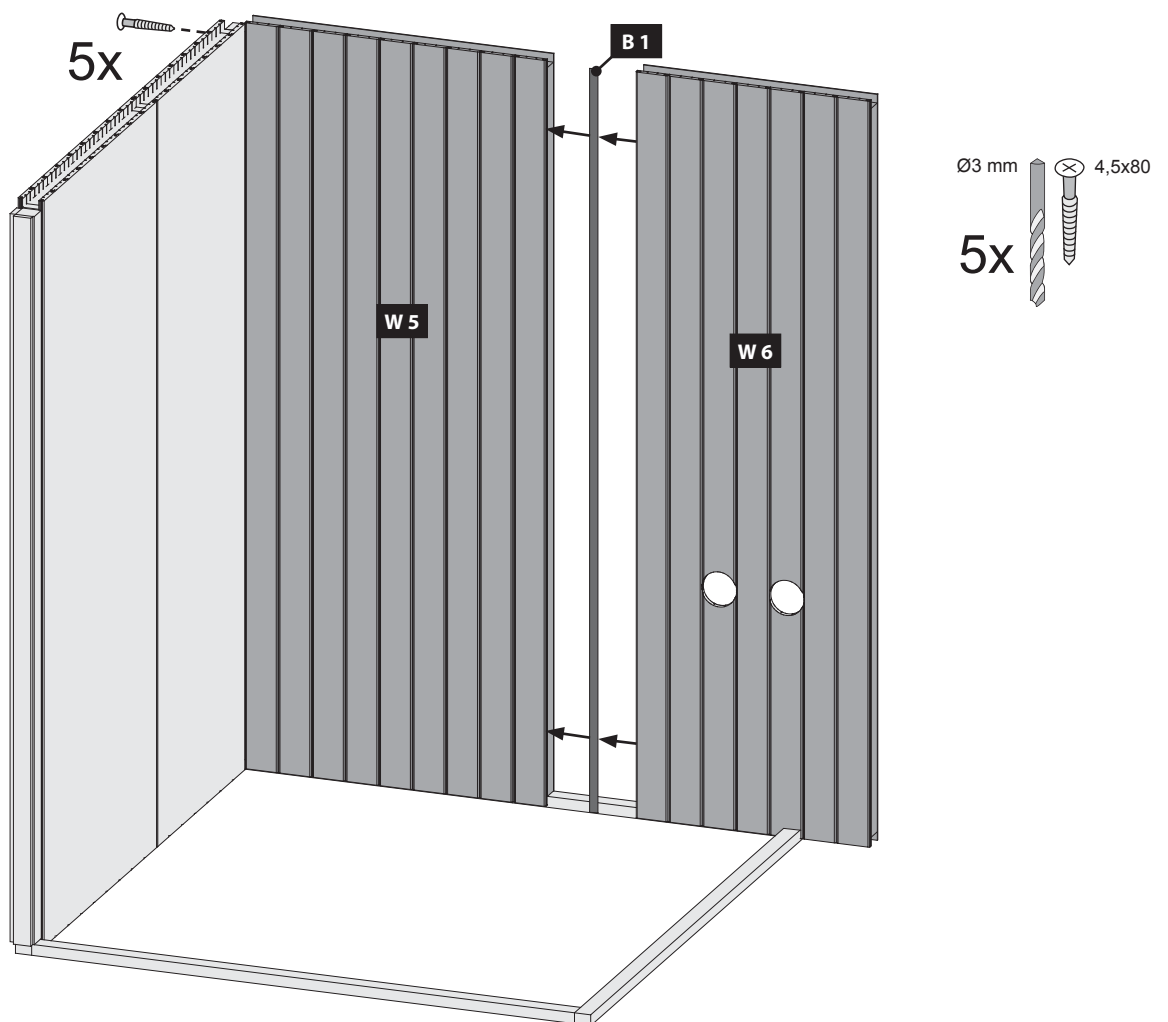
02**03****04**

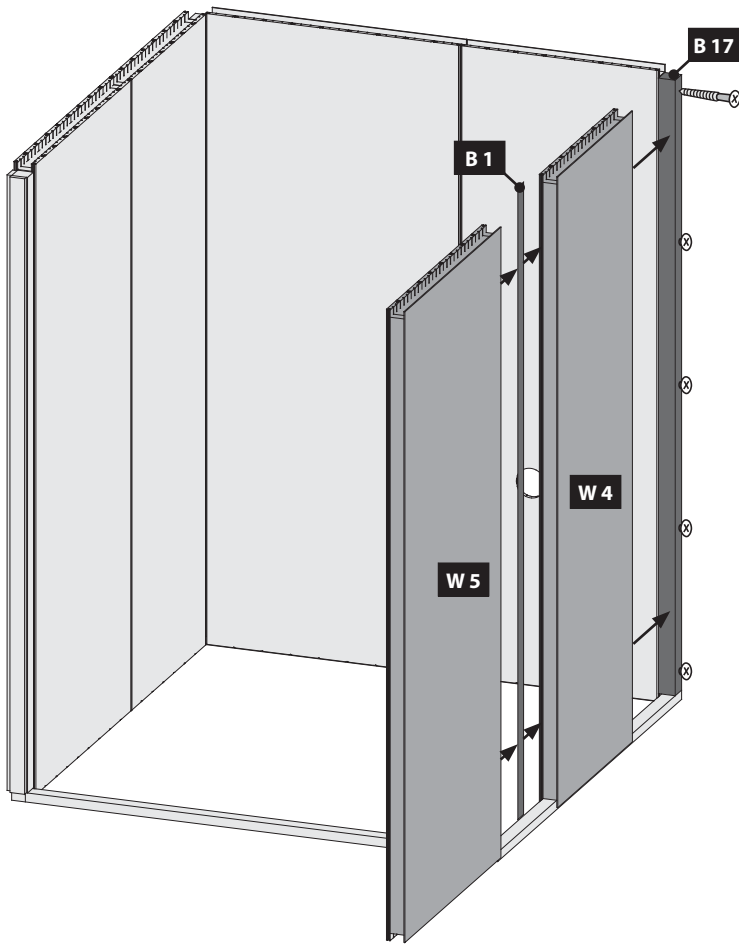

Ø3 mm  4,5x80
5x

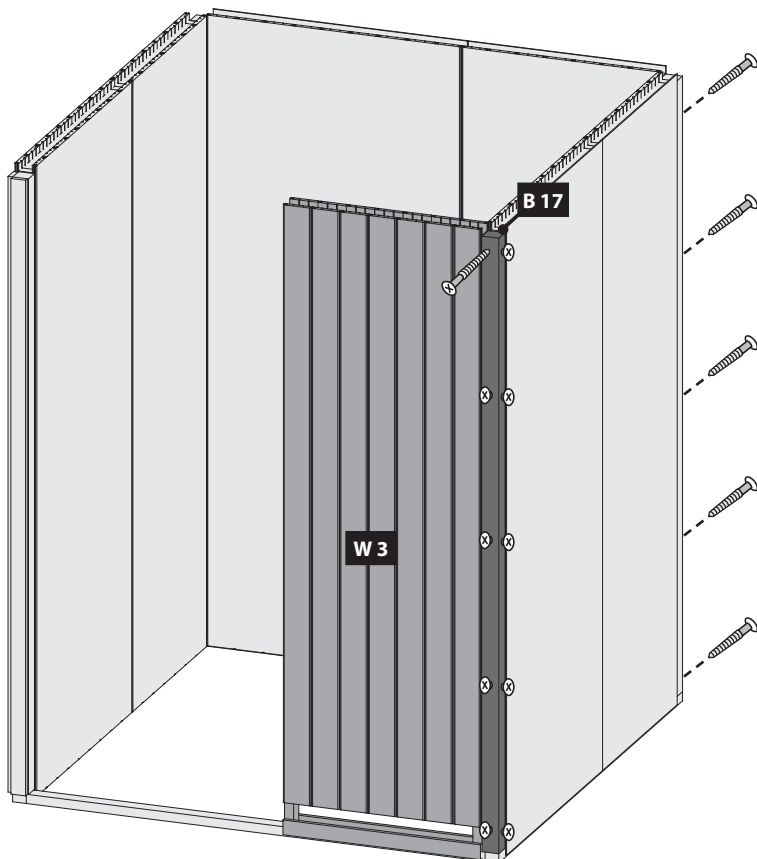
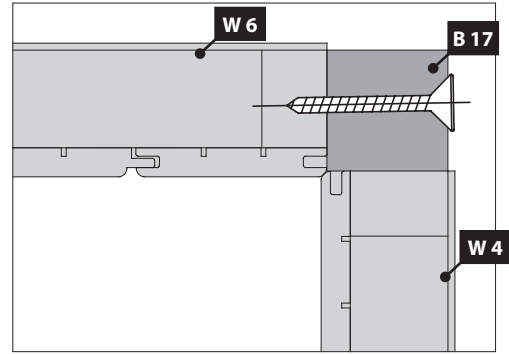

Ø3 mm  4,5x80
15x

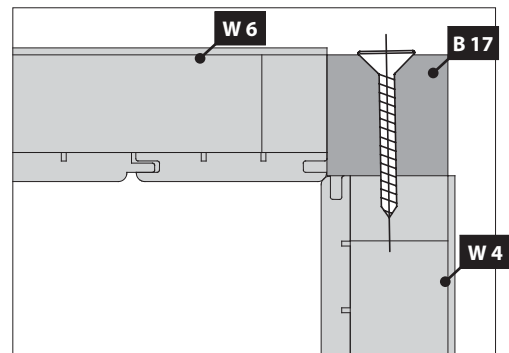



Einbau Glastür

Montage porte en verre

Installation of glass door

Montage van de glazen deur

Montaje de la puerta de cristal

Installazione portello di vetro

!!! 01 — 03 !!!

07

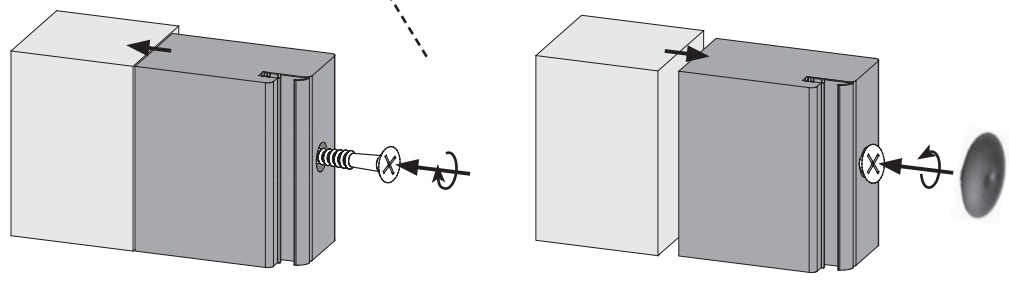
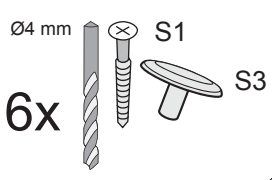
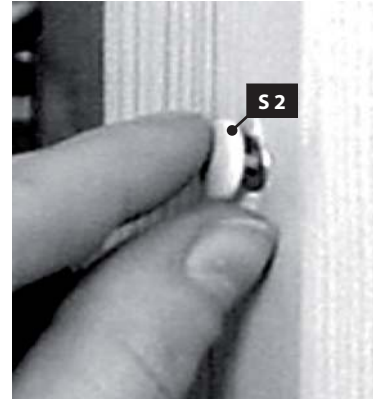
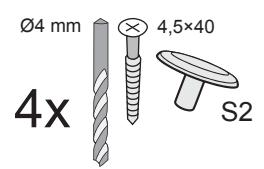
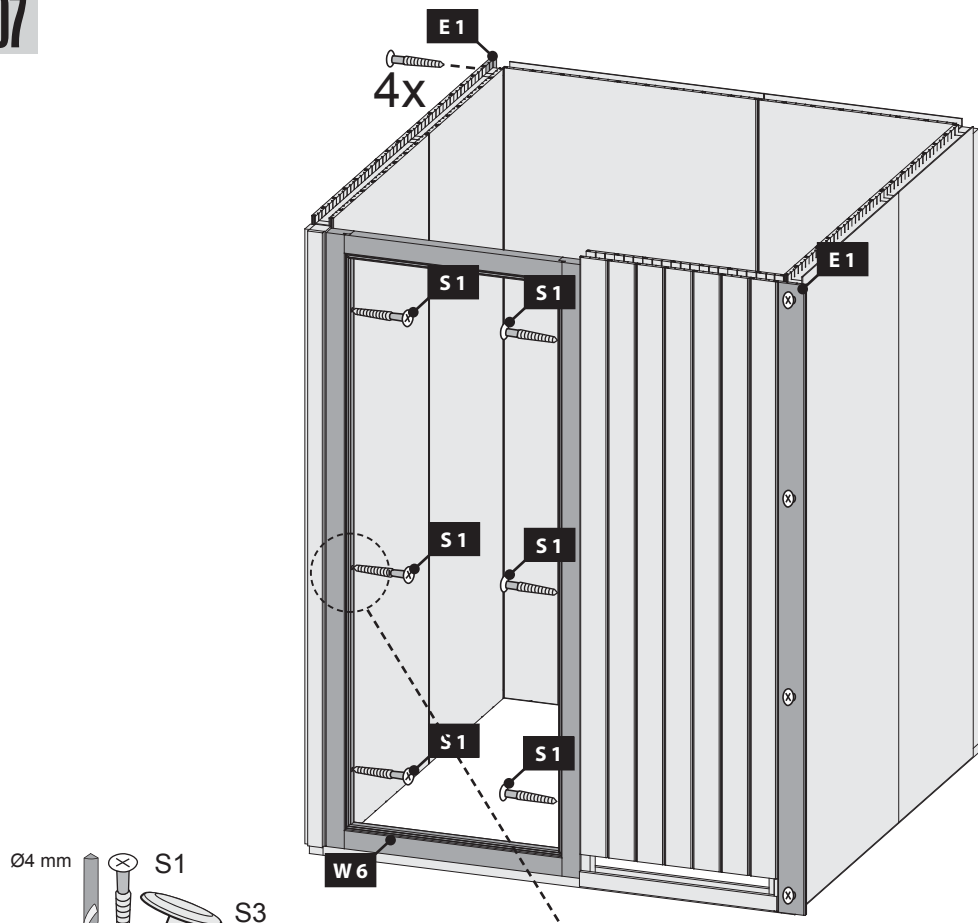

08

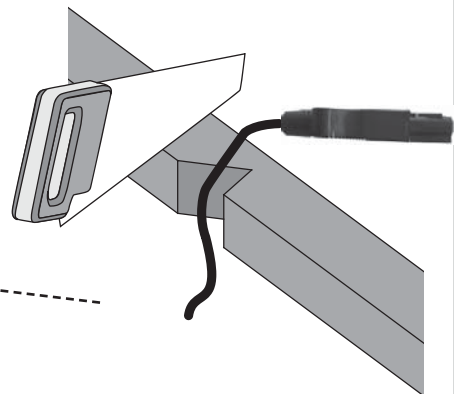
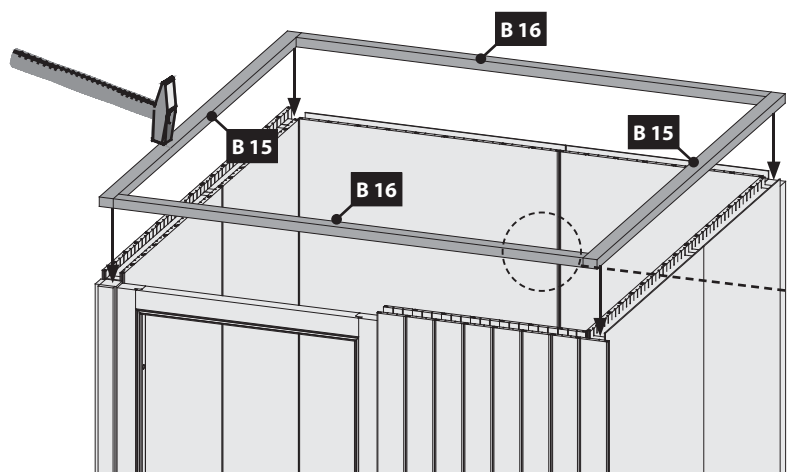

4x

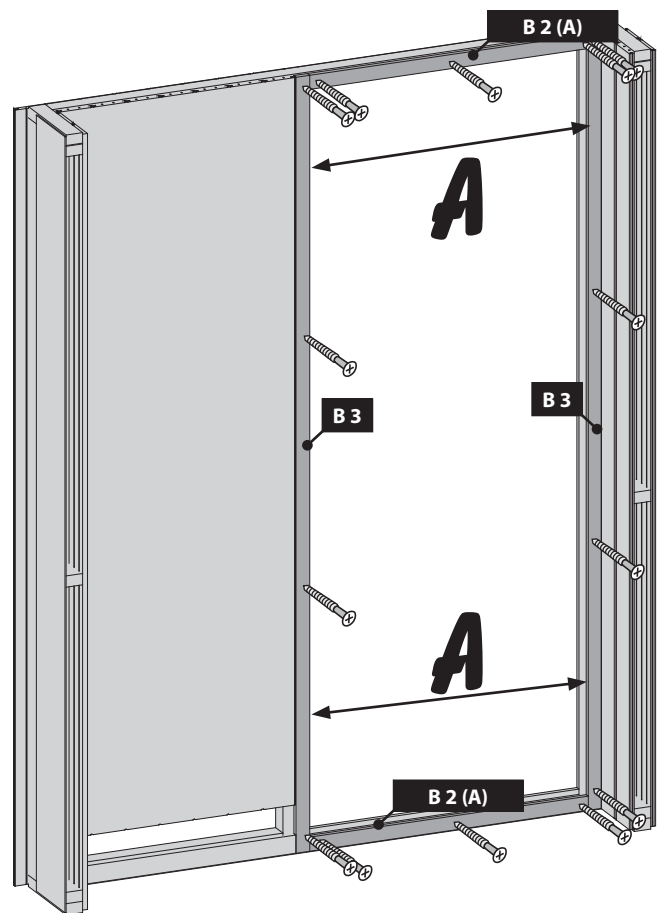
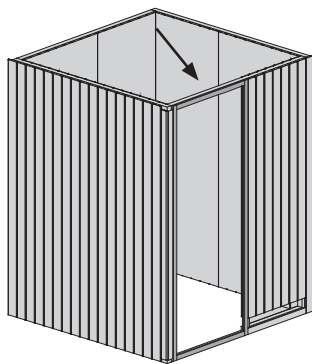
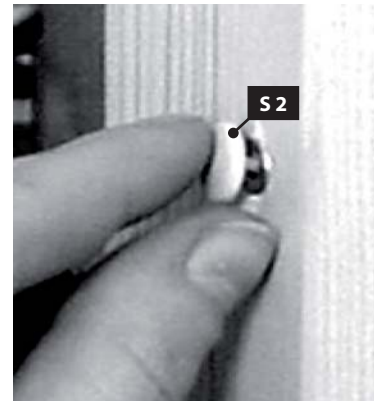
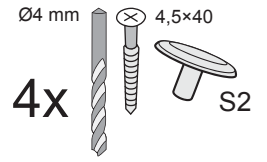
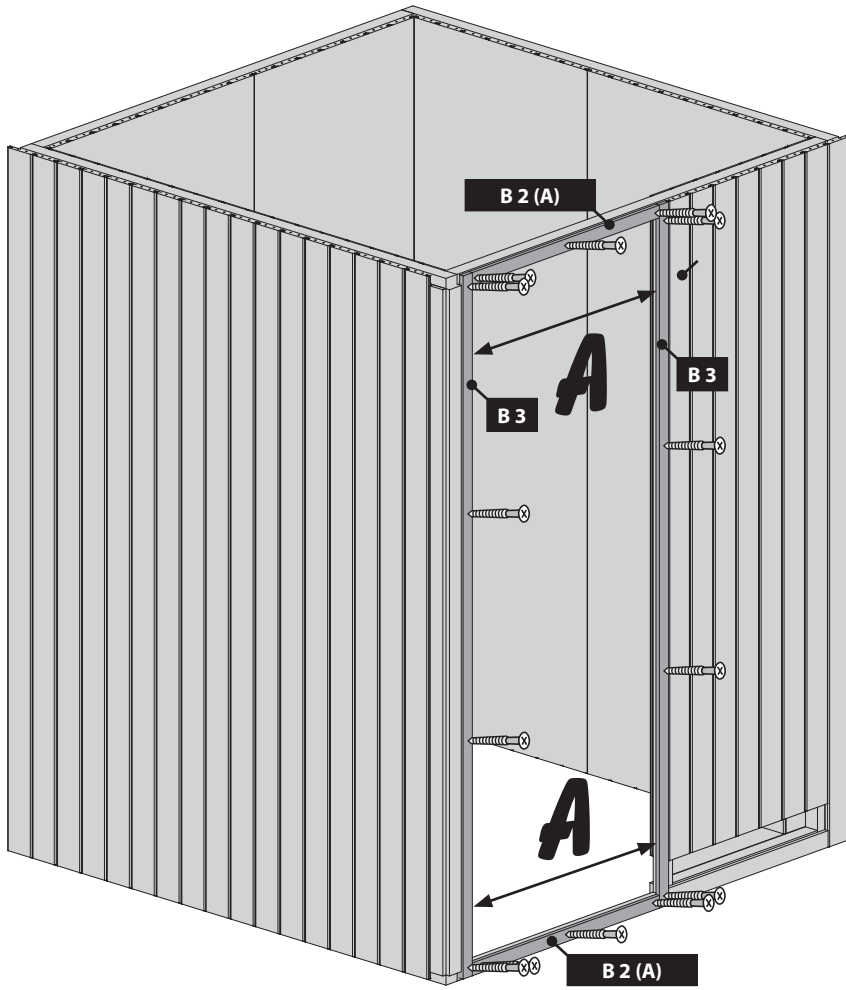
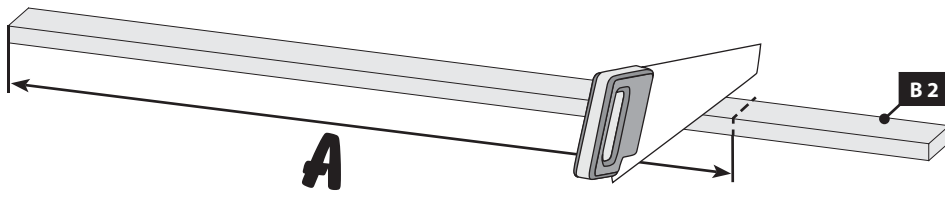

Ø3 mm 4x50
14x

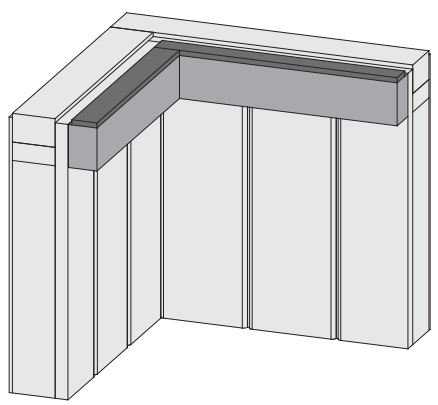
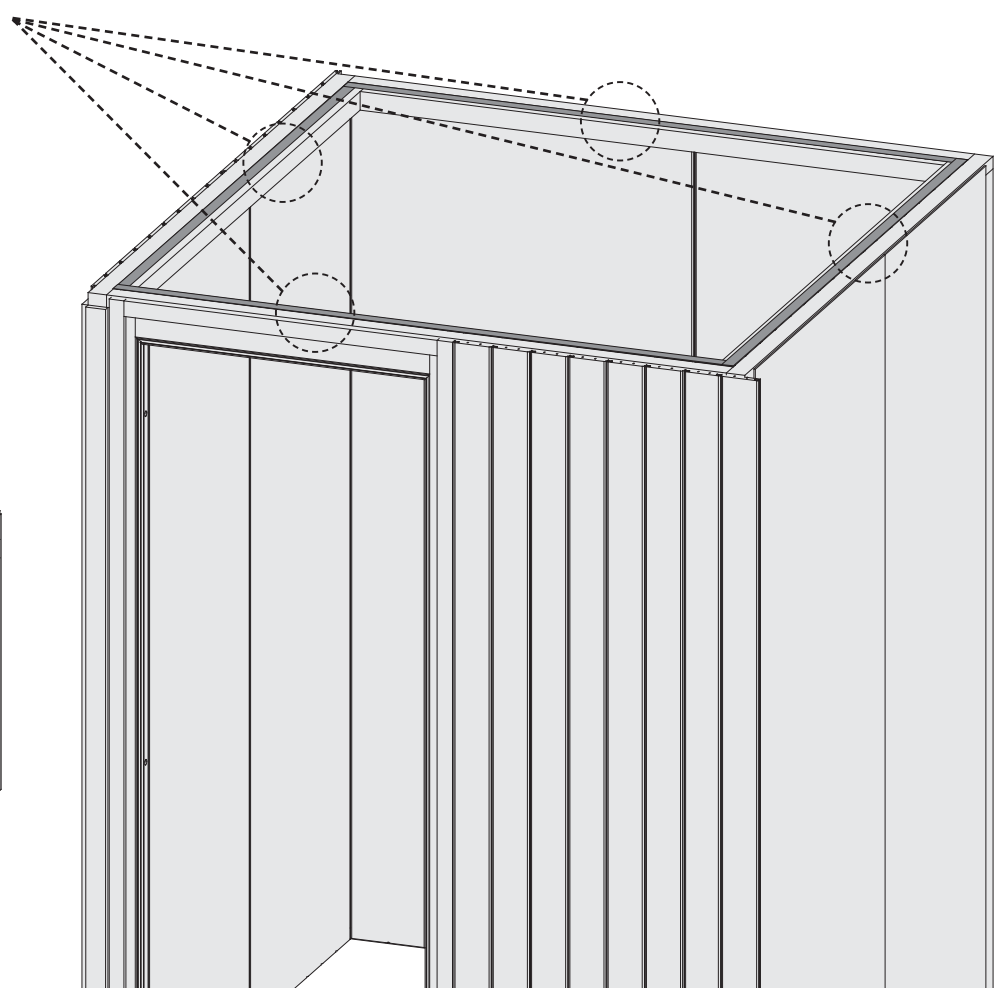
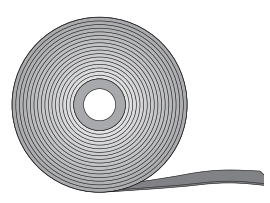
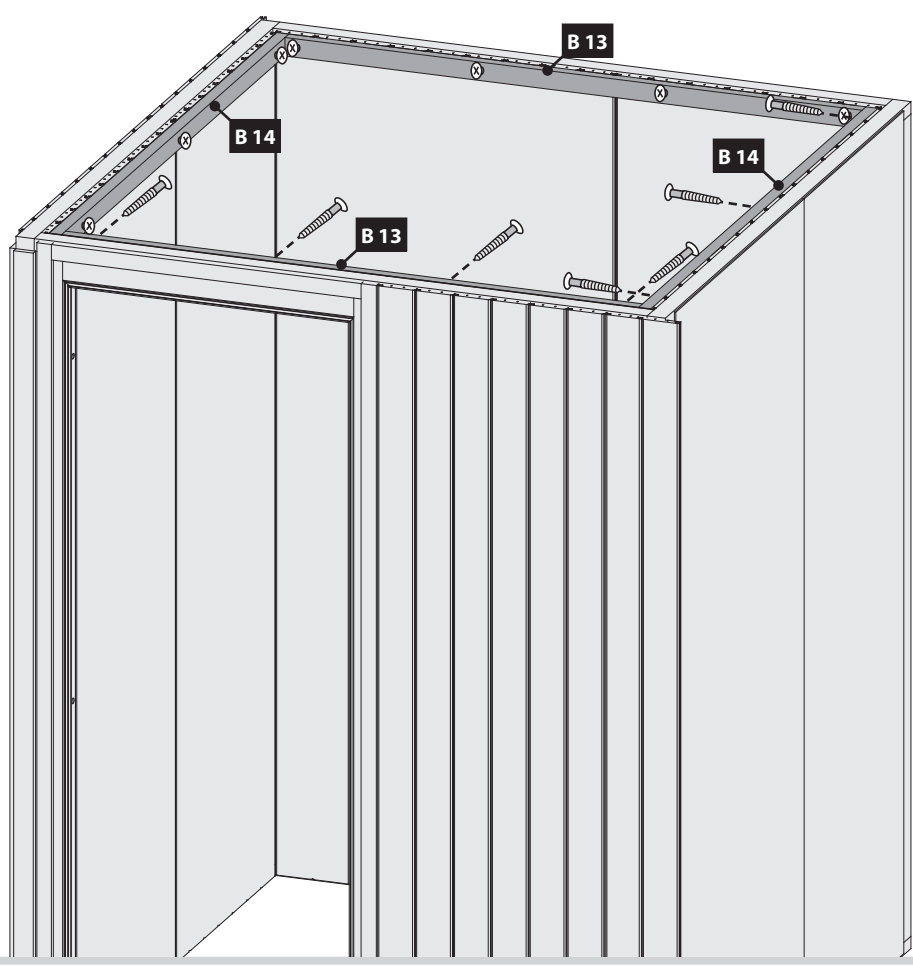

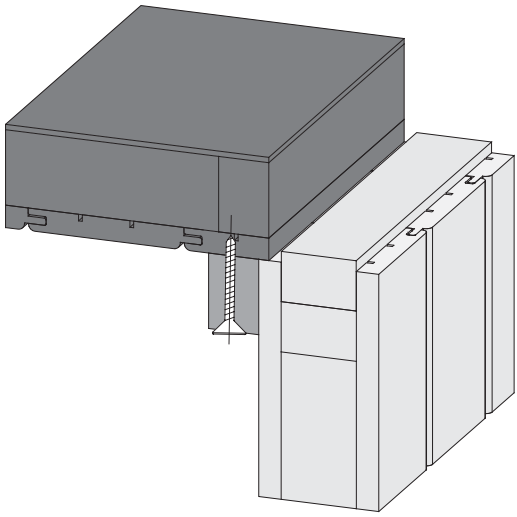
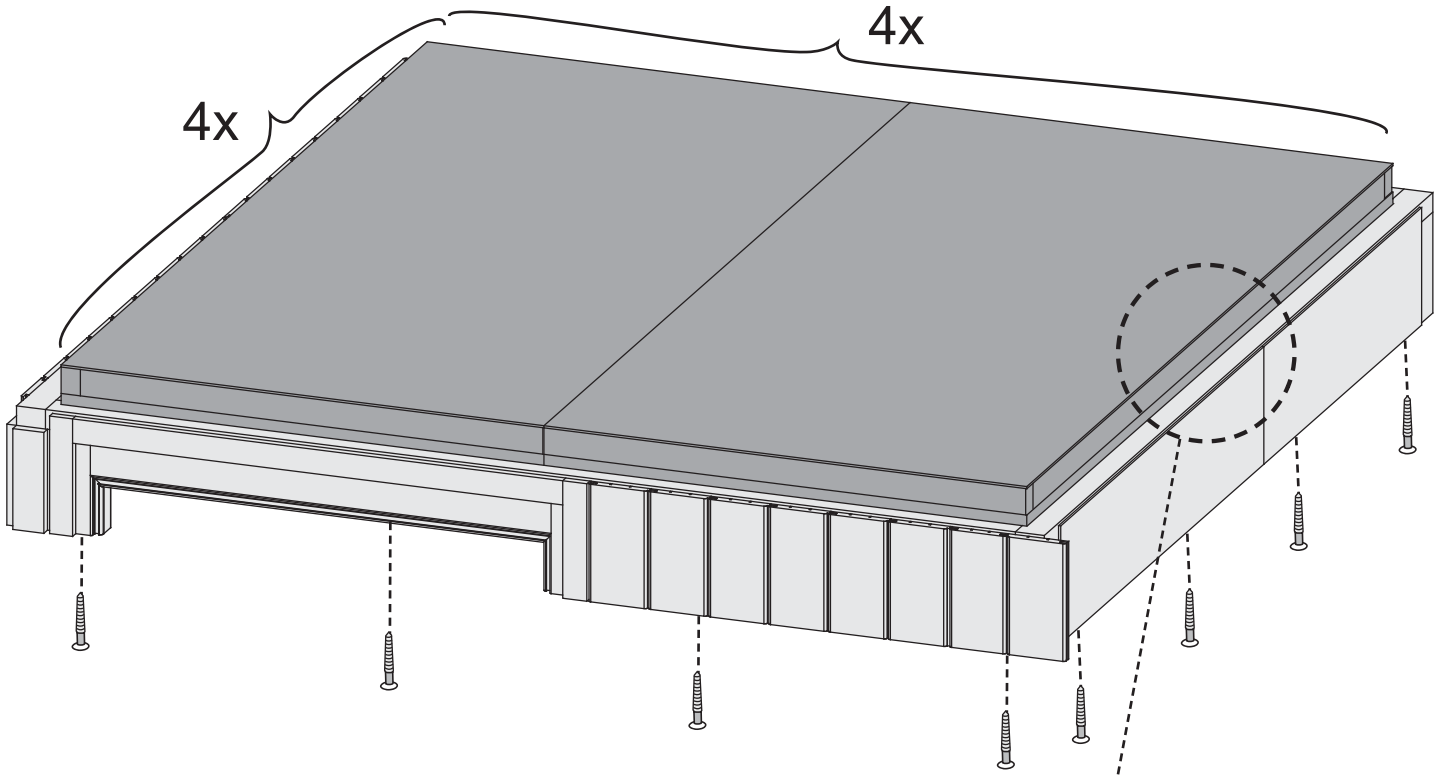
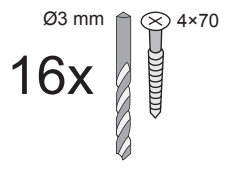
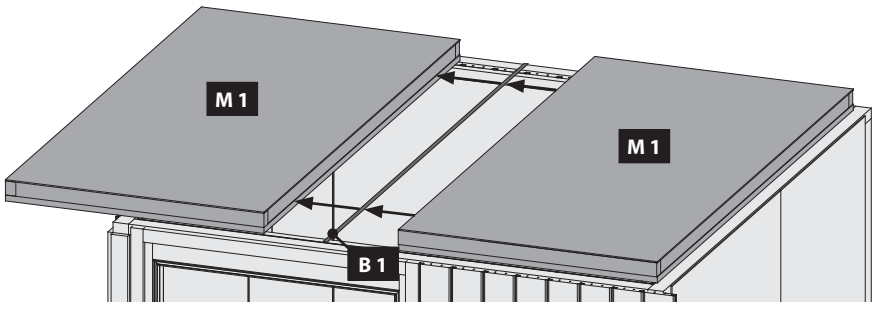

14

Ø4 mm
24x
4,5x40
S2

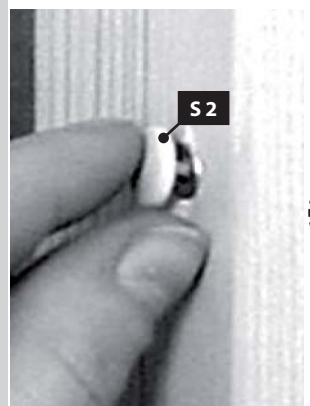
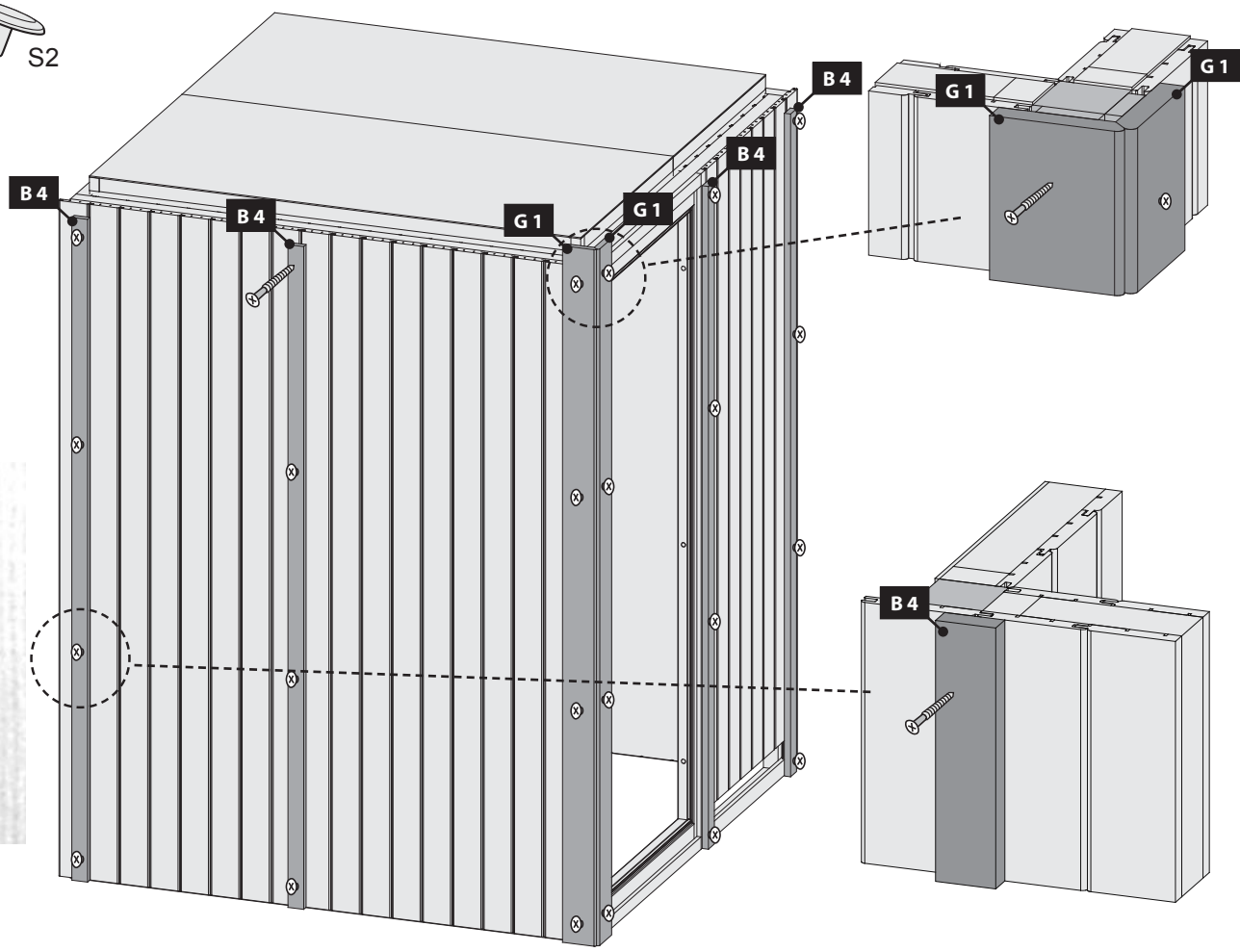

15

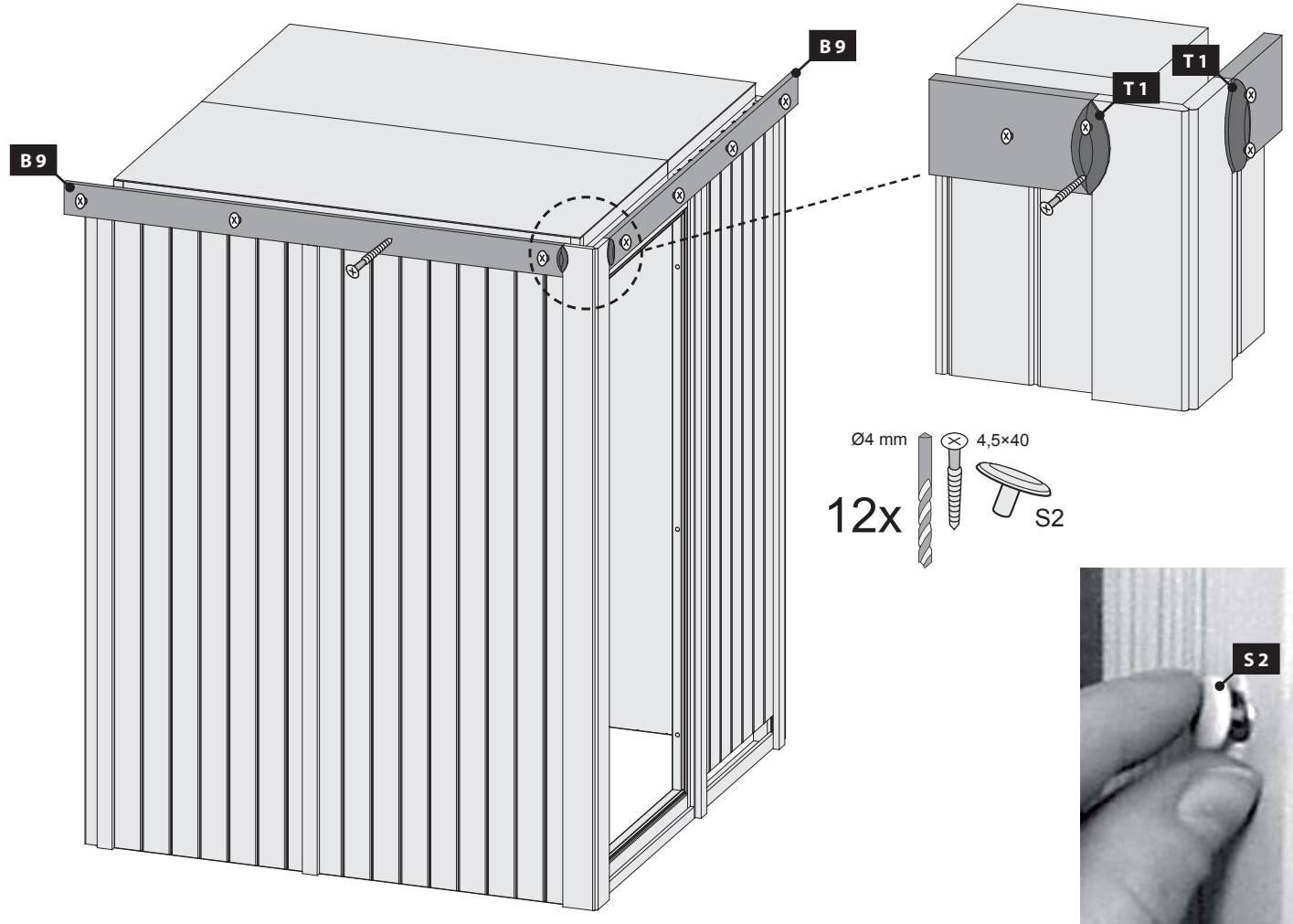

Ø4 mm
12x
4,5x40
S2

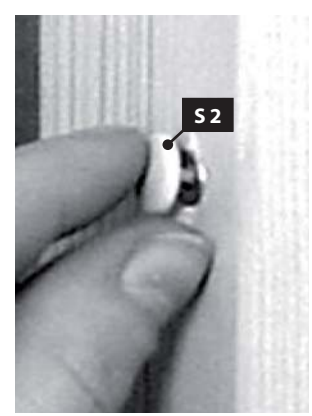

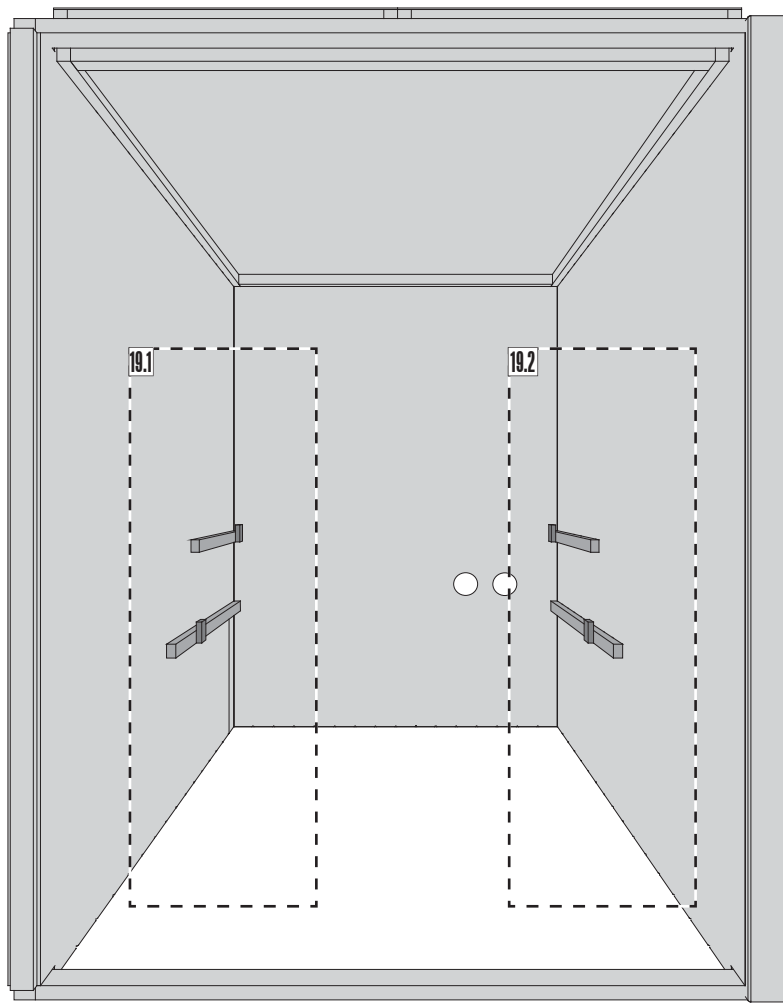

16.1

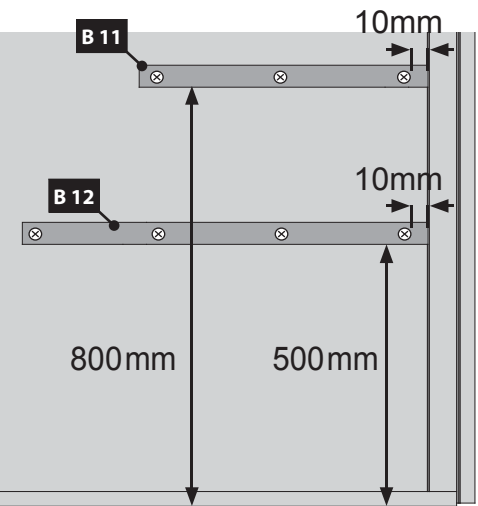

Ø5 mm 6x60
7x

16.2

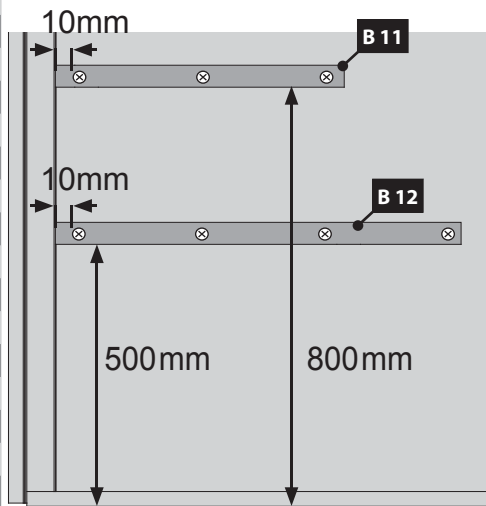

Ø5 mm 6x60
7x

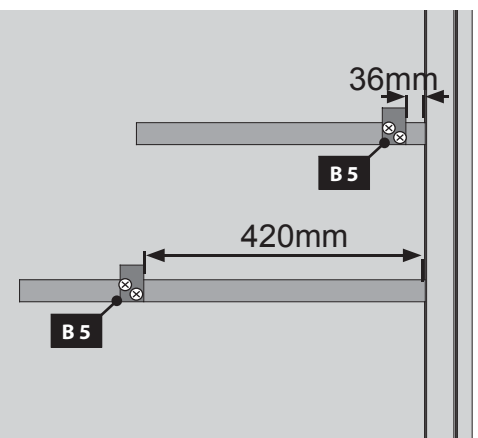

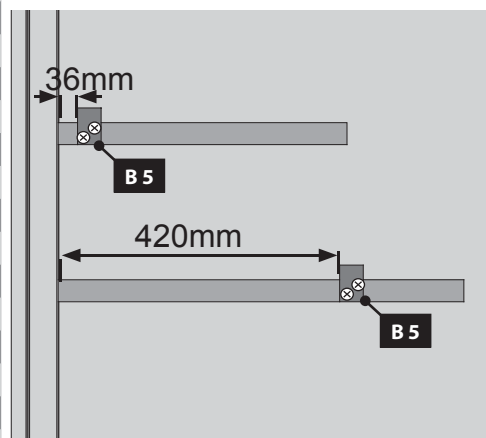

Ø3 mm 4x30
4x



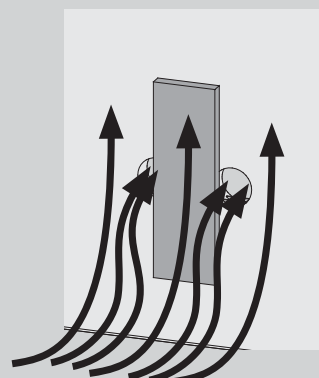
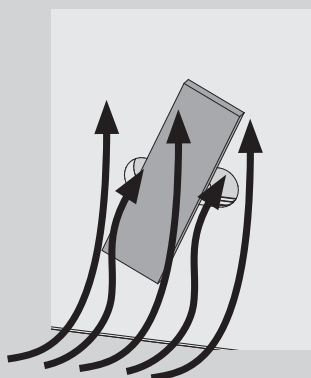
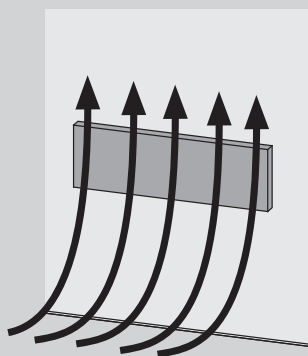
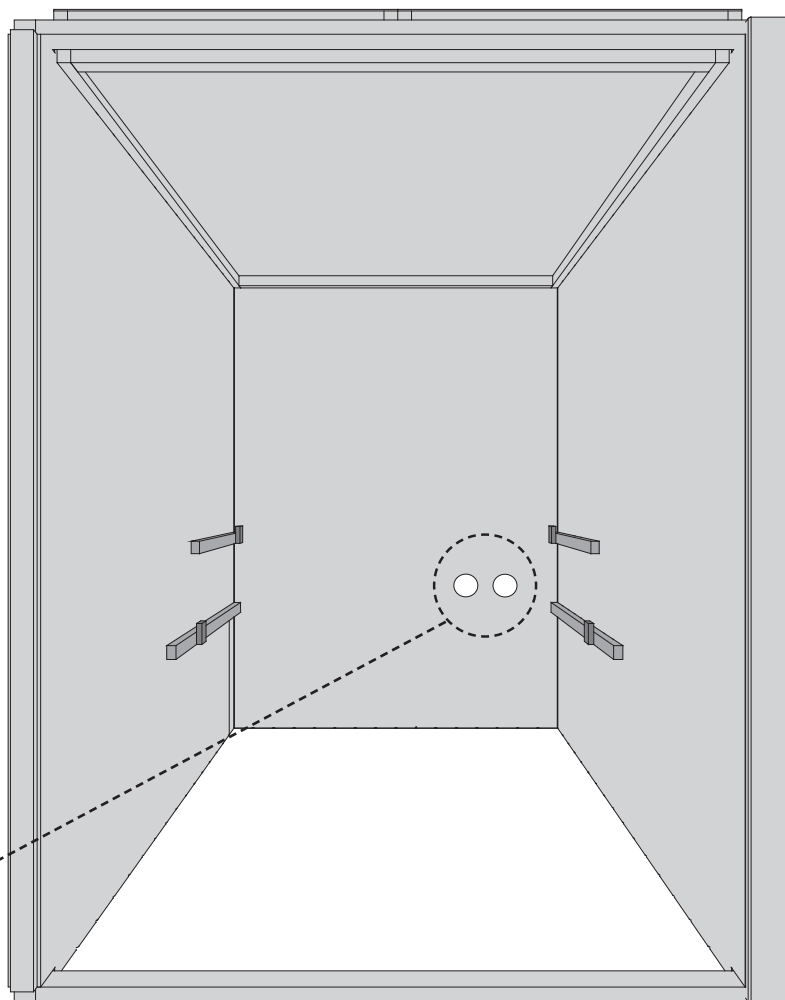
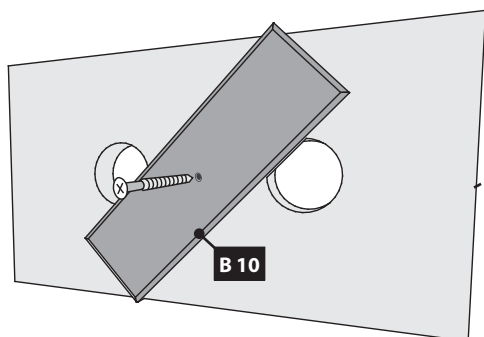

Ø3 mm 4x30
4x

Ø3 mm
1x
4x30





 Hier ist die Funktionsweise des Brettes abgebildet. Regeln Sie damit die Abluft nach Ihren eigenen Wünschen.

 Ceci représente le mode de fonctionnement de la planche. Avec elle, réglez l'écoulement de l'air selon vos désirs.

 This figure shows the functional principle of the board. Regulate the exhaust air according to your own wishes.

 Hier is de werking van het plankje afgebeeld. Regel daarmee de luchtafvoer naar eigen wens.

 Aquí está representada la forma de funcionamiento de la tabla. Regule con ello el aire de salida según sus propios deseos.

 Viene illustrato il principio di funzionamento della tavoletta di regolazione della ventilazione. Con essa si può regolare a piacere la ventilazione.

 Zde je zobrazená funkce desky. Regulujte s ní odsávací vzduch dle Vašeho přání.

2x

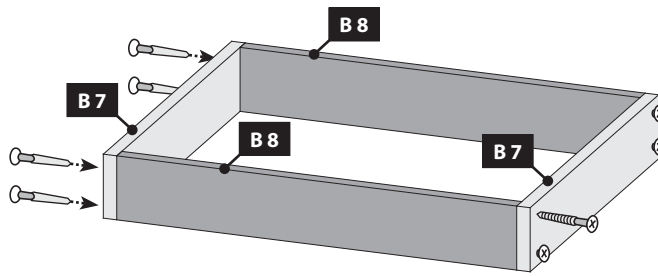

Ø3 mm 4x30

16x

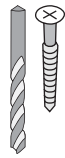

18

-  Nur bei 9 kW-Ofen
-  Seulement 9 kW chauffe
-  Only 9 kW heater
-  Slechts 9 kW heater
-  Sólo calentador de 9 kW
-  Solo riscaldamento 9 kW
-  Pouze topné těleso 9 kW

Ø3 mm 4x30

16x

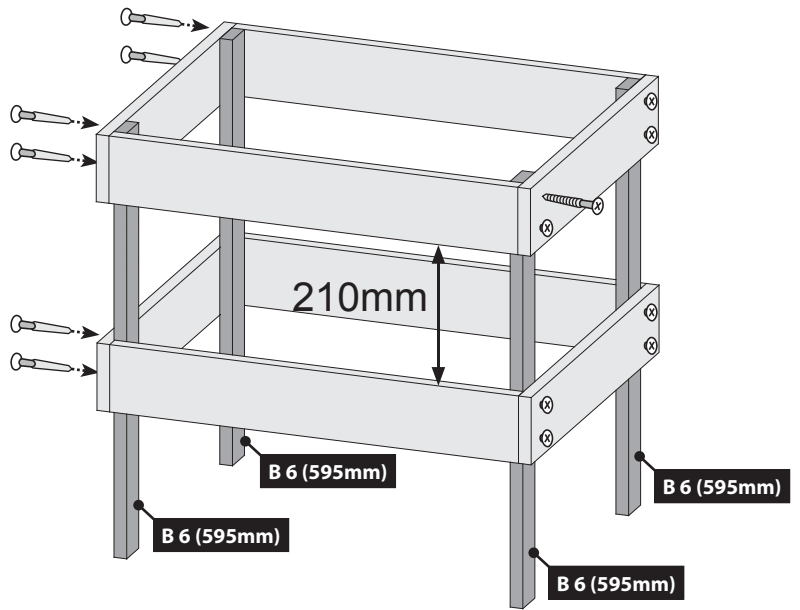
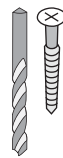

18 a

4x

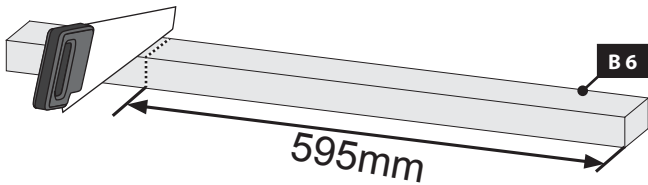

-  Bei allen anderen Öfen
-  Pour tous les autres fours
-  For all other furnaces
-  Voor alle andere ovens
-  Para todos los otros hornos
-  Per tutti gli altri tipi di forni
-  U všech ostatních pecích

Ø3 mm 4x30

16x

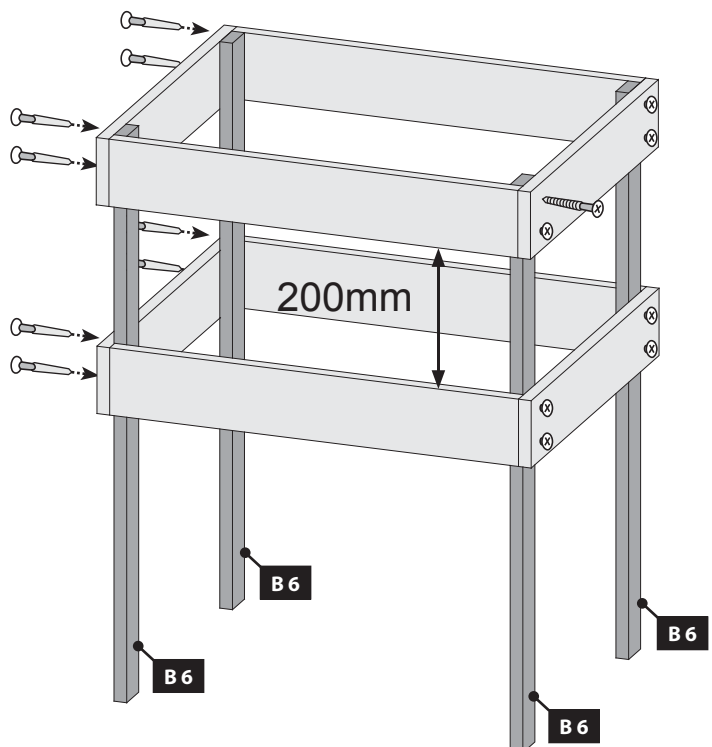
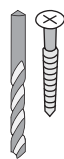

18 b

19

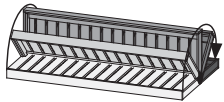

Ø3 mm 4x50

10x

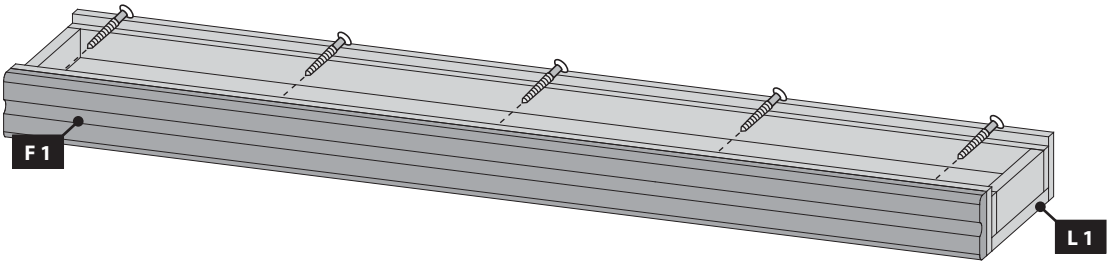
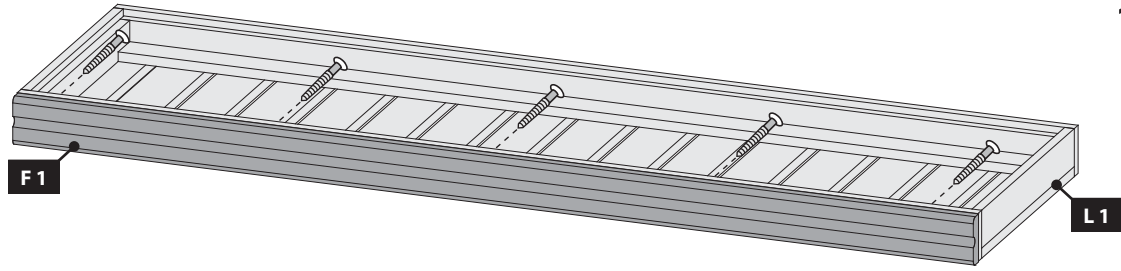
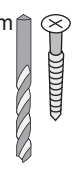

20

Ø3 mm 4x50

4x

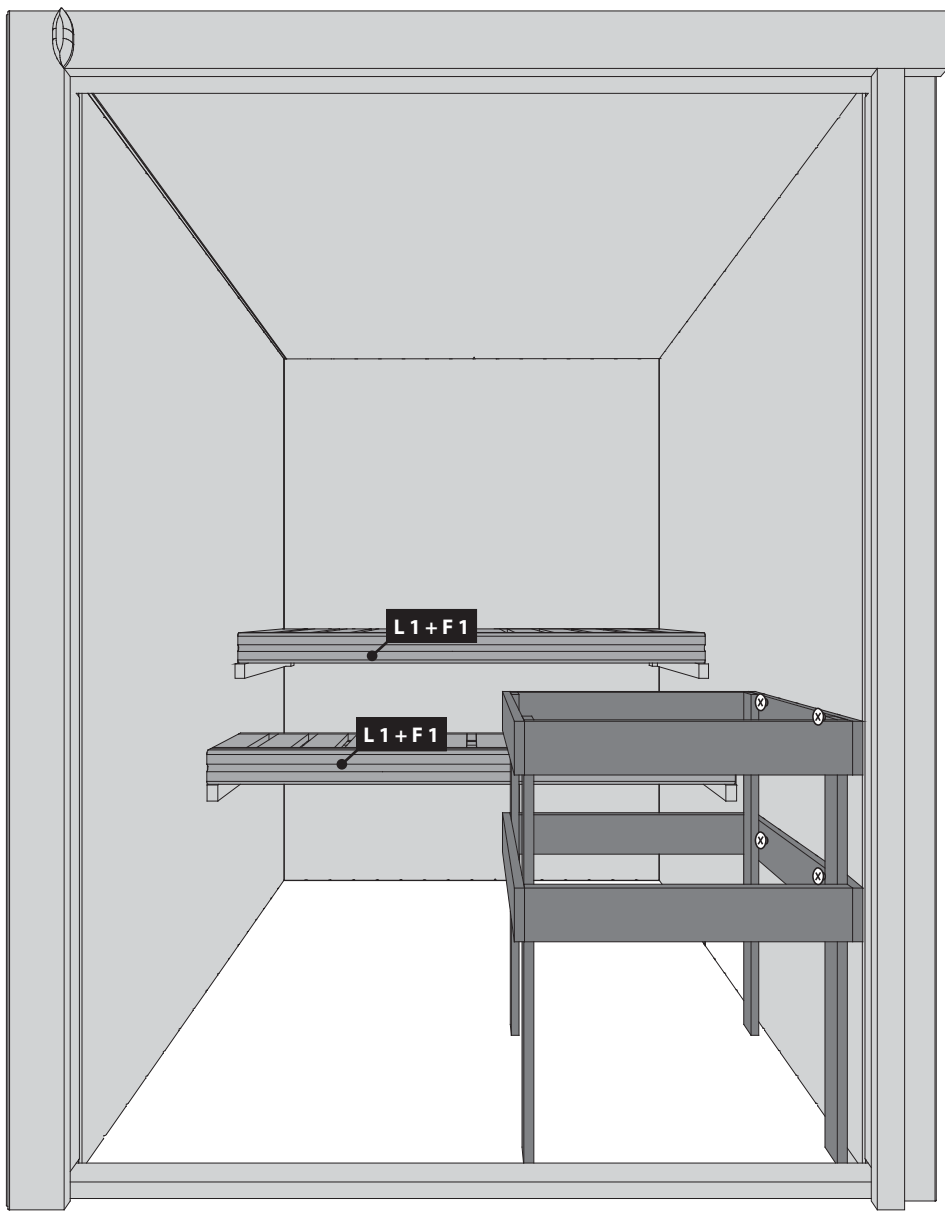



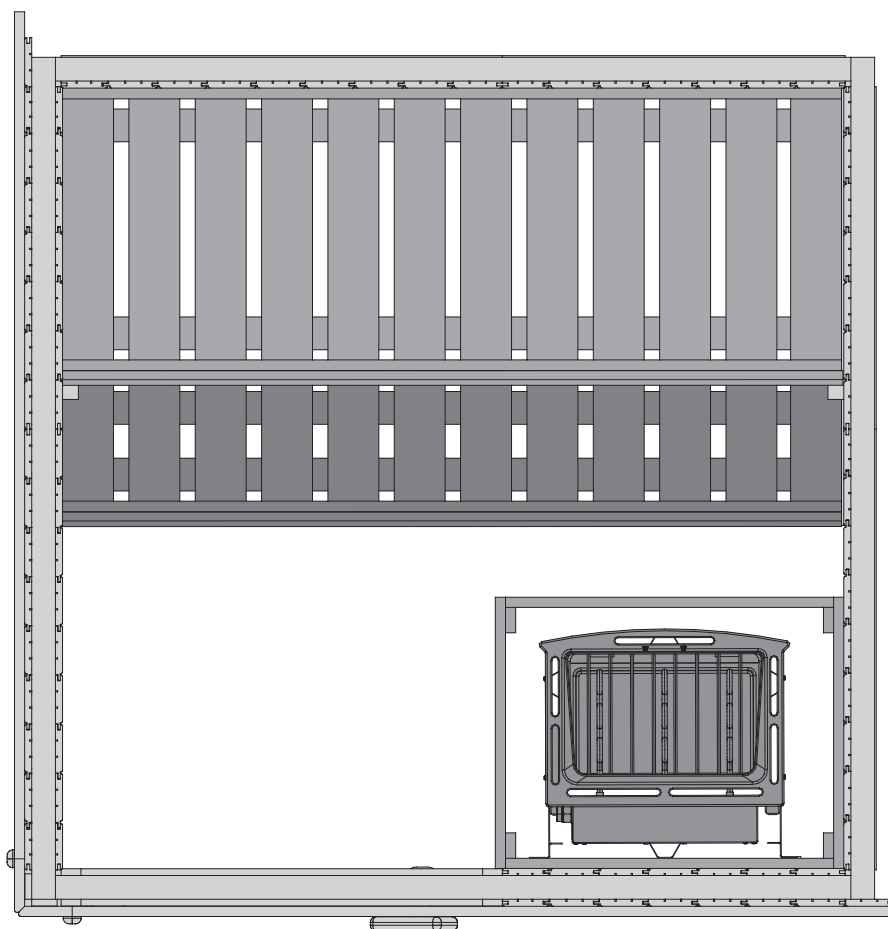
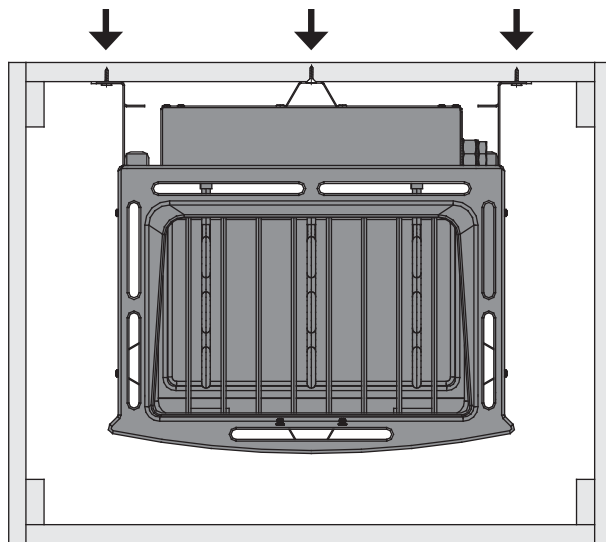
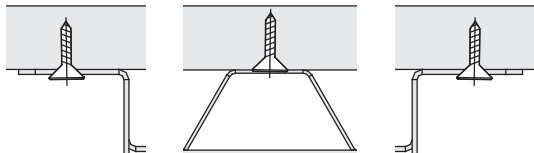



-  Ofenbefestigung
-  oven vaststelling
-  oven fixing
-  fixation four
-  fijación horno
-  fissaggio forno
-  upevňovací trouba



04 — 08



-  Einbau Glastür
-  Installation of glass door
-  Montage porte en verre
-  Montage van de glazen deur

-  Montaje de la puerta de cristal
-  Installazione portello di vetro
-  Namestitev steklena vrata



70337

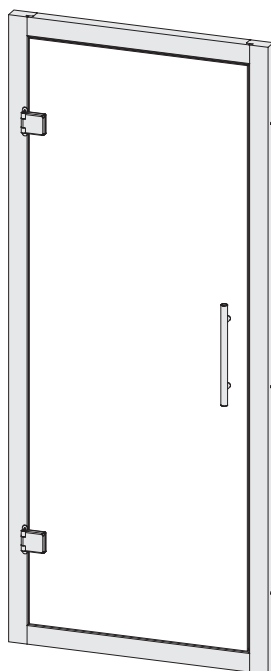

-  **Aufbauanleitung**
-  **Building Instructions**
-  **notice de montage**
-  **montagehandleiding**
-  **Montagevejledning**
-  **Instrucciones de construcción**
-  **Istruzioni per il montaggio**
-  **Montážní návod**

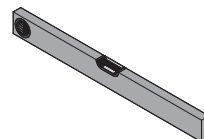
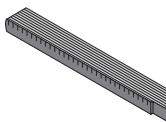
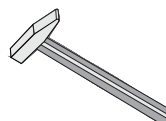
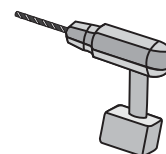
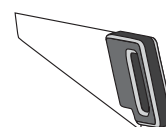



Vergleichen Sie zuerst die Material-liste mit Ihrem Paketinhalt! Bitte haben Sie Verständnis, dass Beanstandungen nur im nicht aufgebauten Zustand bearbeitet werden können!



Vergelijk eerst de lijst van materialen met de inhoud van uw pakket! Reclamaties kunnen alleen in behandeling worden genomen zolang de onderdelen nog niet zijn gemonteerd!



Confrontate questa distinta materiali prima con il contenuto del pacchetto! Vi preghiamo di comprendere che eventuali reclami possono essere accolti solo prima del montaggio!



First compare the list of materials with your package contents! Please understand that complaints can be processed in the non-built status only!



Start med at kontrollere materialelisten med indholdet af den leverede pakke! Vi gør venligst opmærksom på at reklamationer kun kan behandles for materialer som ikke er blevet bearbejdet!



Nejprve přezkontrolujte obsah balení podle materiálového listu! Mějte pochopení pro to, že případnou reklamaci se můžeme zabývat pouze tehdy, když díly nebudou smontované! Za pomoci tohoto seznamu můžete jednotlivé díly přiřadit k montážnímu návodu.



Commencez par comparer la liste du matériel avec le contenu de votre paquet! Sachez que nous traitons uniquement les réclamations concernant le matériel à l'état non monté!



En primer lugar, compare la lista de material con el contenido del paquete. Rogamos entienda que las reclamaciones sólo pueden ser tramitadas antes de montar el objeto!

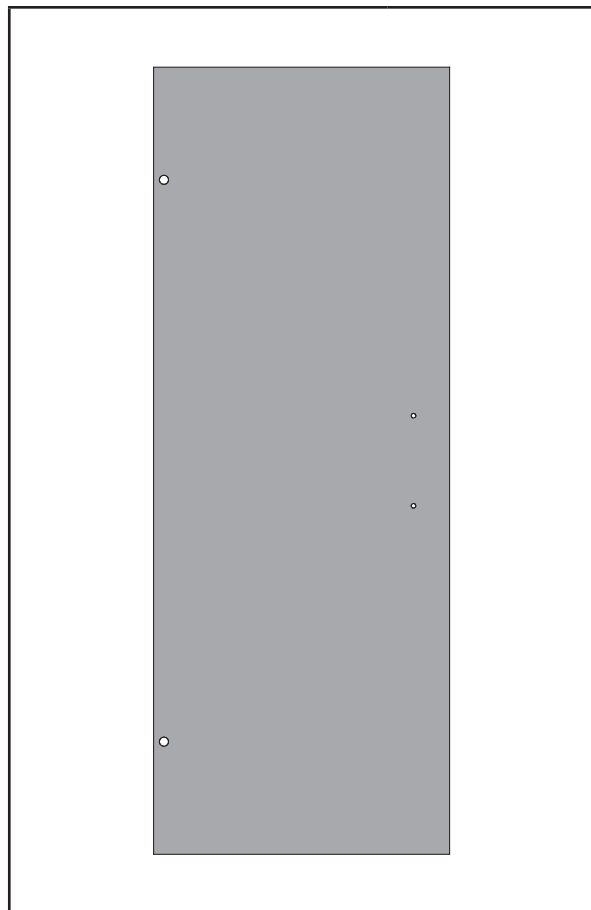
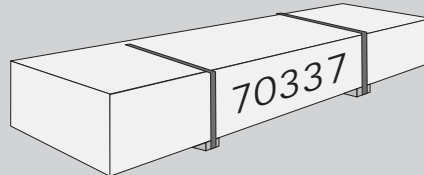

1 x

ID 70350

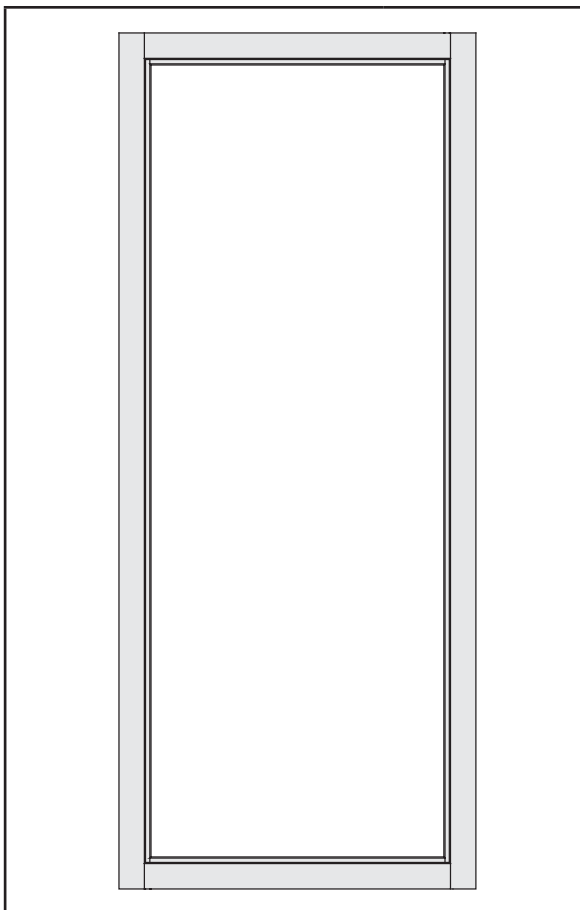

1 x

ID 26499



Bitte beachten Sie, dass es sich bei einem Spontanbruch infolge von Nickelsulfideinschlüssen um Glasbrüche handelt, die nicht auf Verarbeitungsfehler basieren und somit nicht durch den Hersteller und dem Verarbeiter zu vertreten sind. Der Spontanbruch ist als hinzunehmendes Allgemeinrisiko anzusehen.

Bitte haben Sie Verständnis, dass wir eine Nachlieferung nur gegen Berechnung ausführen können.

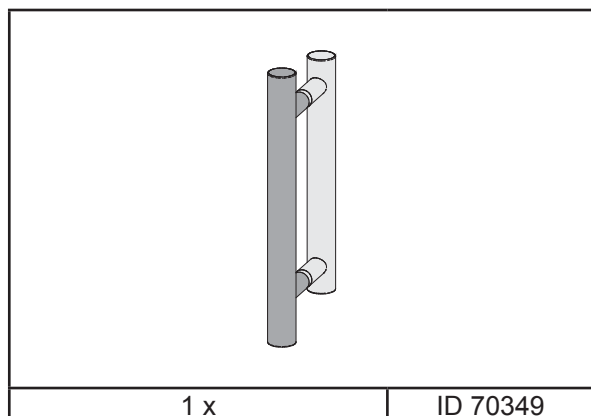



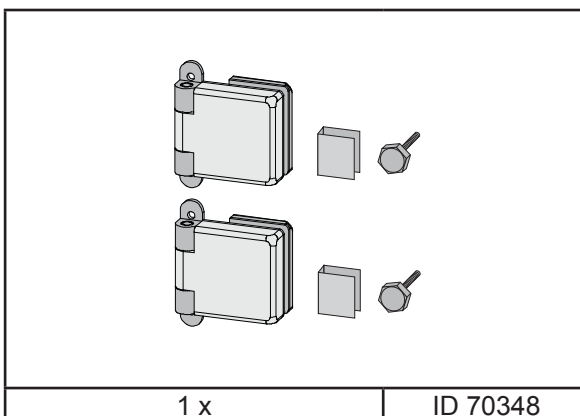

1 x





ID 70349



1 x

ID 70348

-  Einbau Glastür
-  Installation of glass door
-  Montage porte en verre
-  Montage van de glazen deur

-  Installationsglasdør
-  Montaje de la puerta de cristal
-  Installazione portello di vetro
-  Sauna Instalace dveře

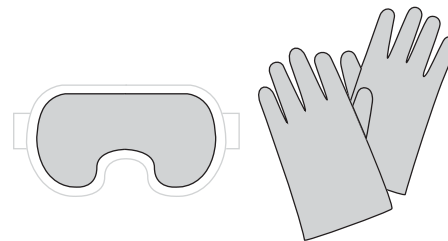

01



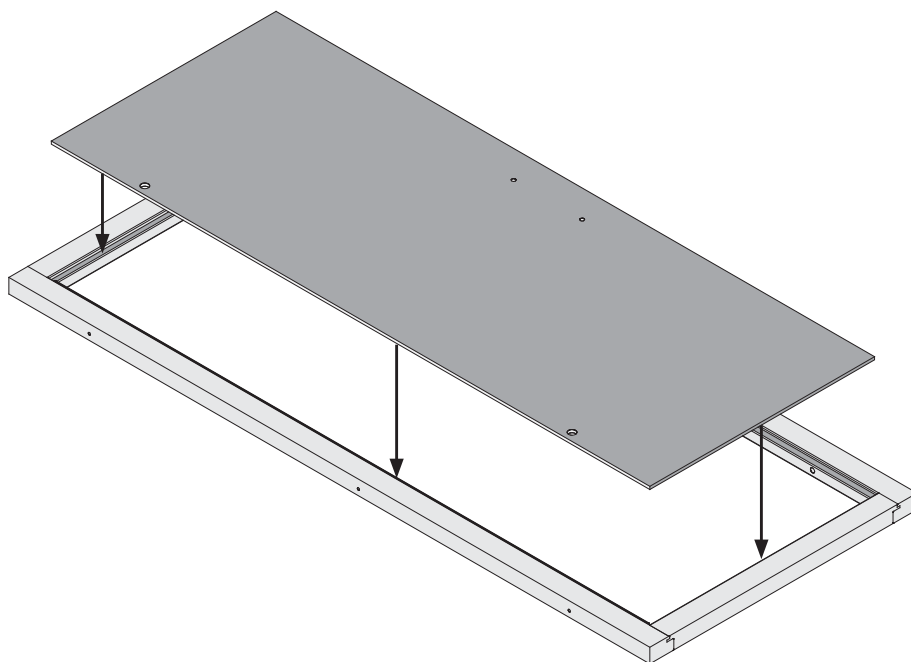

-  Saunätürglas in den Türrahmen legen
-  Put the door glass in the frame
-  Mettez le verre de la porte dans le cadre
-  Plaats het deurglas in het frame
-  Sæt dørglasset i rammen
-  Pon el vidrio de la puerta en el marco
-  Metti il vetro della porta nel telaio
-  Vložte sklo dveří do rámu



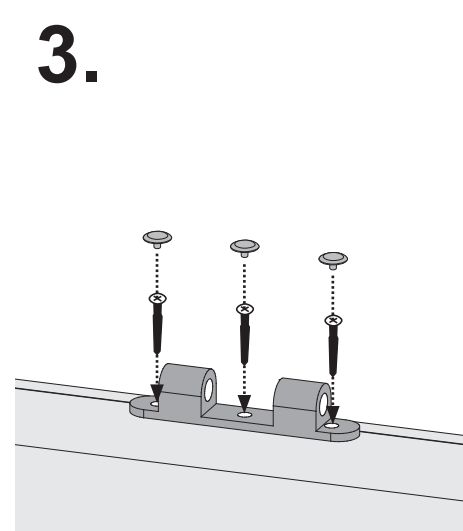
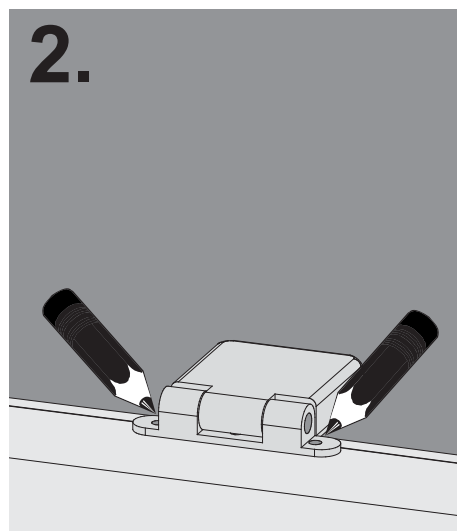
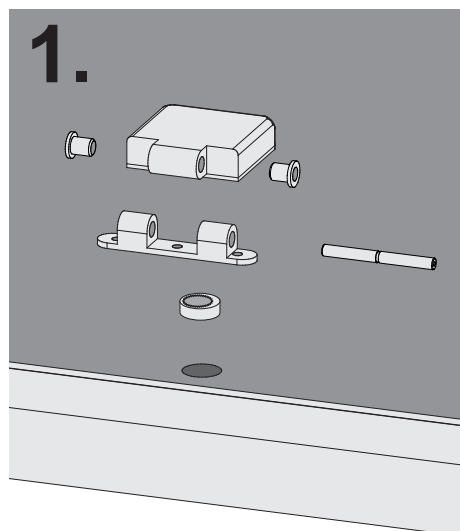
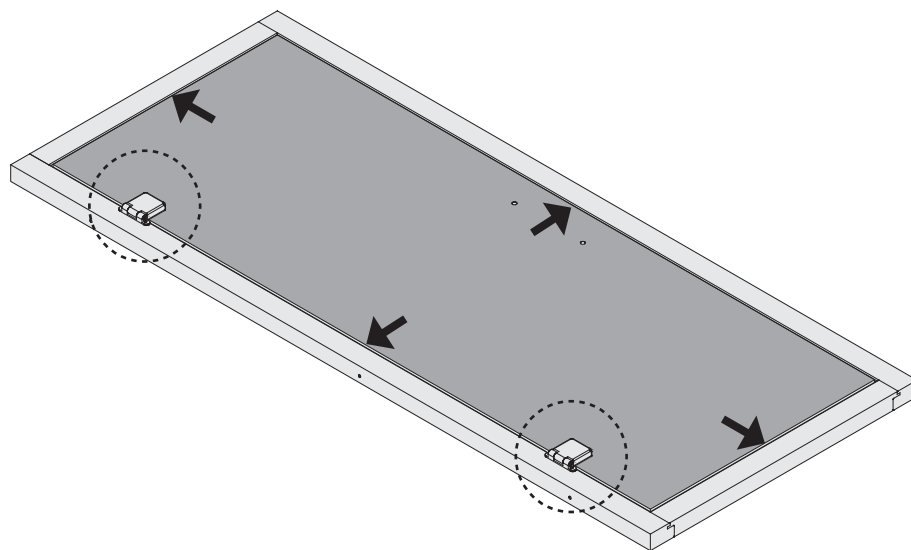



02

-  Saunätürglas in den Türrahmen ausrichten
-  Center the glass in the wooden frame
-  Bien aligner le verre à vitre
-  Lijn het glas uit in het deurframe
-  Juster saunaens dørglas i dørkarmen
-  Alinee el vidrio en el marco de la puerta
-  Allineare il vetro nel telaio della porta
-  Skleněná dvířka sauna v zárubně zarovnat



 Einbau Glastür
 Installation of glass door
 Montage porte en verre
 Montage van de glazen deur

 Installationsglasdør
 Montaje de la puerta de cristal
 Installazione portello di vetro
 Sauna Instalace dveře

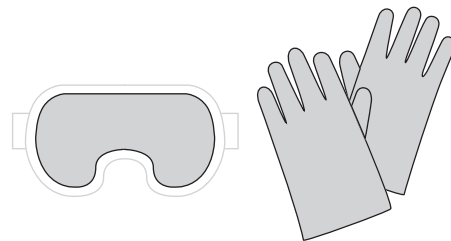

03

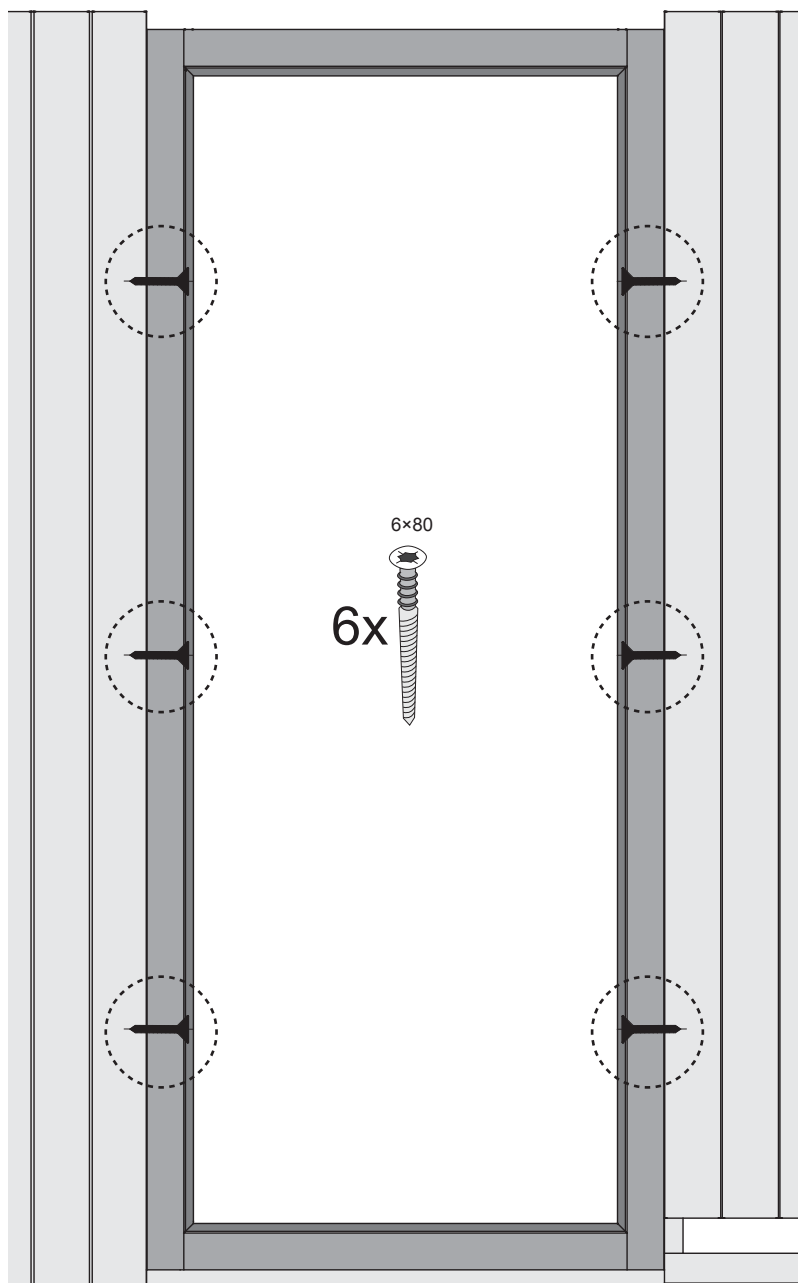
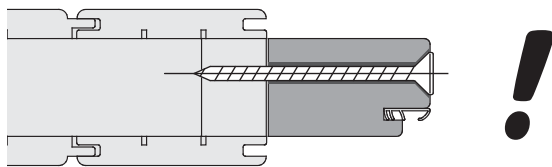



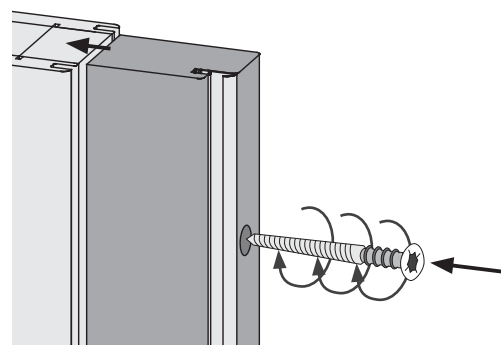



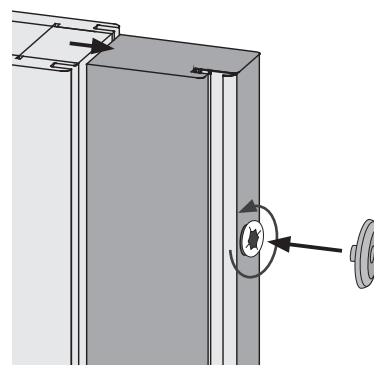

1.



2.



-  Einbau Glastür
-  Installation of glass door
-  Montage porte en verre
-  Montage van de glazen deur

-  Installationsglasdør
-  Montaje de la puerta de cristal
-  Installazione portello di vetro
-  Sauna Instalace dveře

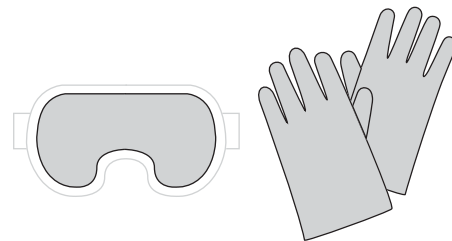

04

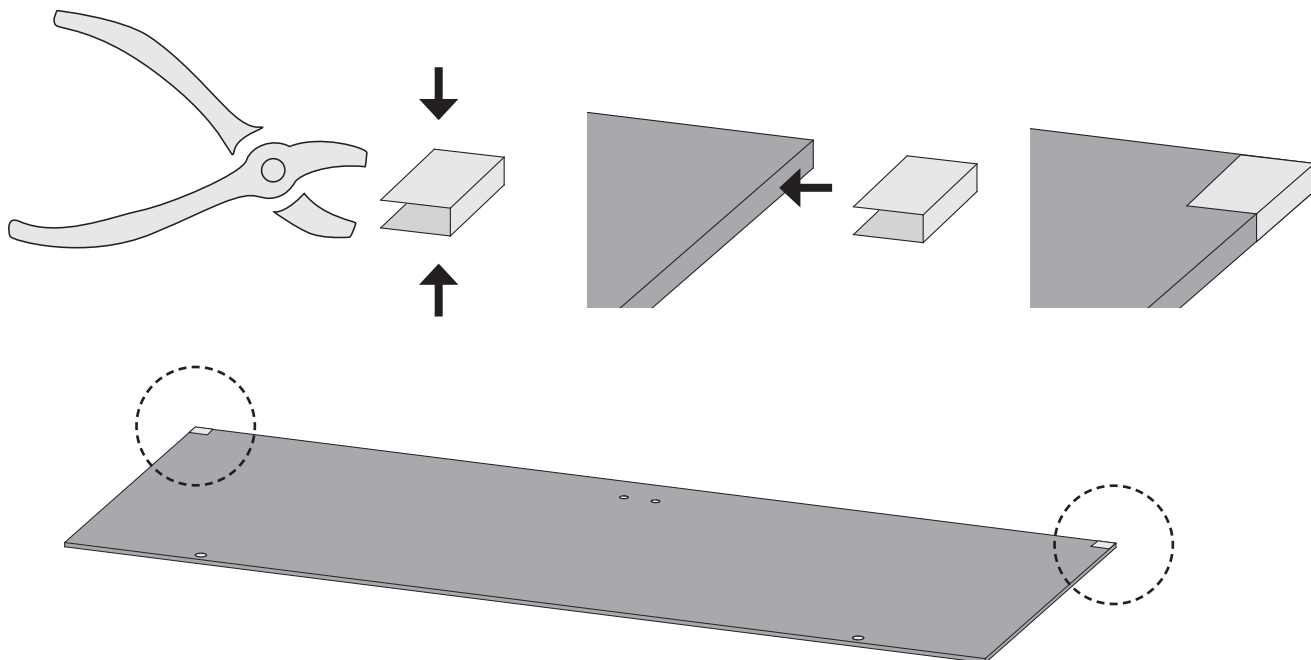



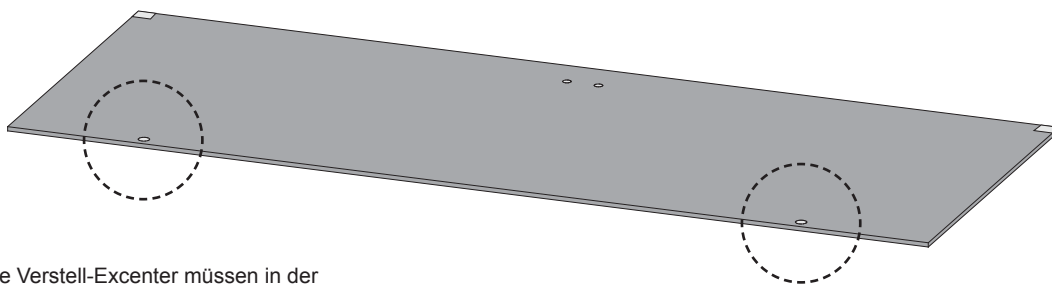



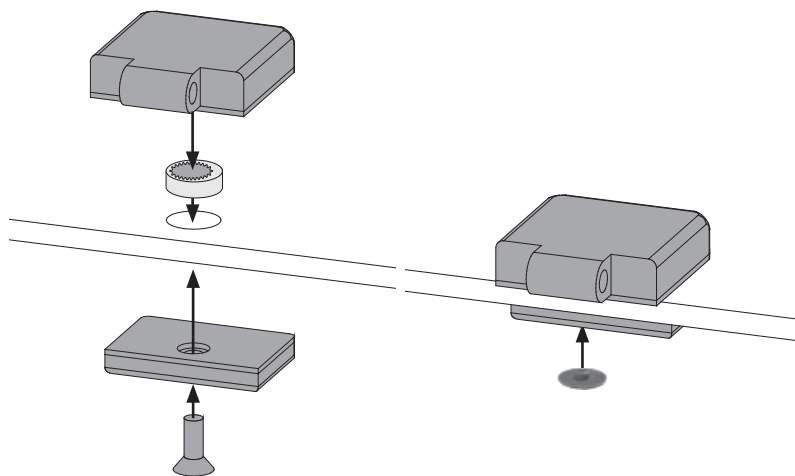

05



-  Alle Verstell-Excenter müssen in der Glasscheibe die gleiche Grundstellung haben
-  All adjustable eccentrics must have the same basic adjustment in the glass panel
-  Tous les excenteurs de positionnement doivent avoir la même position de base dans la vitre
-  Alle excentrische verstelelementen moeten in dezelfde stand in de glasplaat worden geplaatst
-  Alle justeringsexcenter skal have samme grundlæggende position i glasruden
-  Todos los excéntricos regulables tienen que tener la misma posición base en la hoja de cristal
-  Tutti gli eccentrici di regolazione devono avere la stessa posizione base nella lastra di vetro
-  šechny nastavovací podivínů musí mít stejný základní polohy ve skle





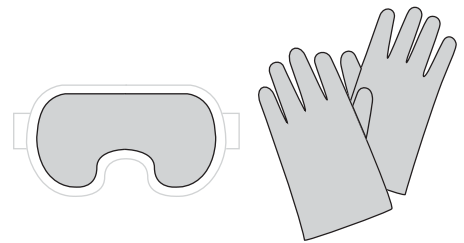

-  Einbau Glastür
-  Installation of glass door
-  Montage porte en verre
-  Montage van de glazen deur



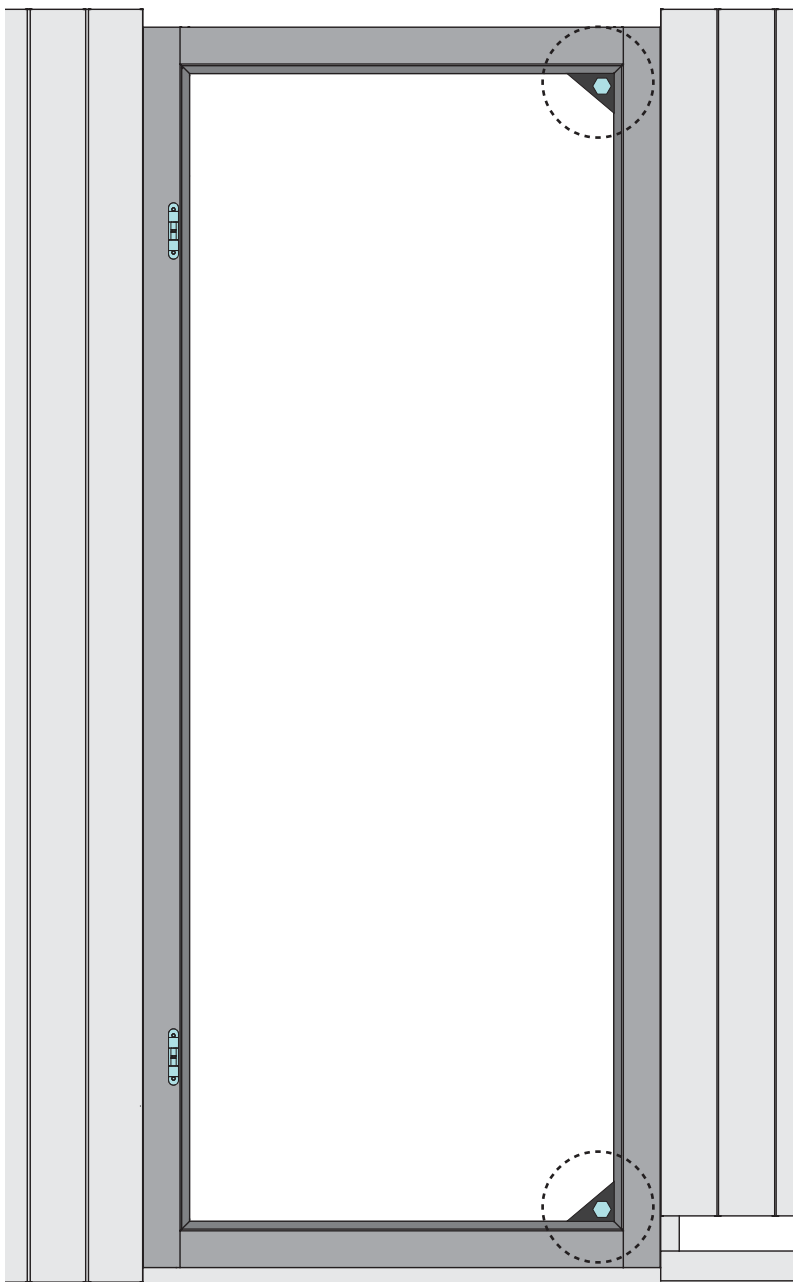

-  Installationsglasdør
-  Montaje de la puerta de cristal
-  Installazione portello di vetro
-  Sauna Instalace dveře



06







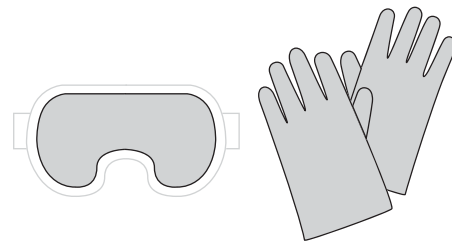



-  Einbau Glastür
-  Installation of glass door
-  Montage porte en verre
-  Montage van de glazen deur

-  Installationsglasdør
-  Montaje de la puerta de cristal
-  Installazione portello di vetro
-  Sauna Instalace dveře



07

-  Alle Verstell-Excenter müssen in der Glasscheibe die gleiche Grundstellung haben
-  All adjustable eccentrics must have the same basic adjustment in the glass panel
-  Tous les excentreurs de positionnement doivent avoir la même position de base dans la vitre
-  Alle excentrische verstelelementen moeten in dezelfde stand in de glasplaat worden geplaatst

-  Alle justeringsexcentricer skal have samme grundlæggende position i glasruden
-  Todos los excéntricos regulables tienen que tener la misma posición base en la hoja de cristal
-  Tutti gli eccentrici di regolazione devono avere la stessa posizione base nella lastra di vetro
-  Šechny nastavovací podivínů musí mít stejný základní polohy ve skle

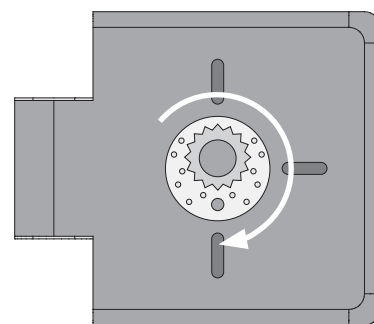
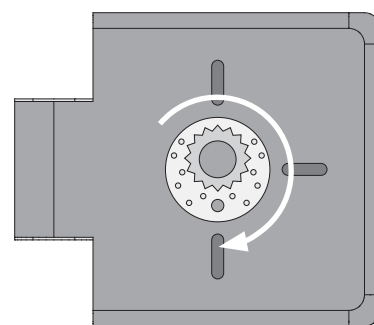
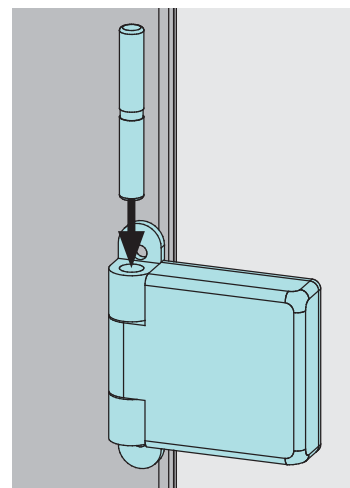
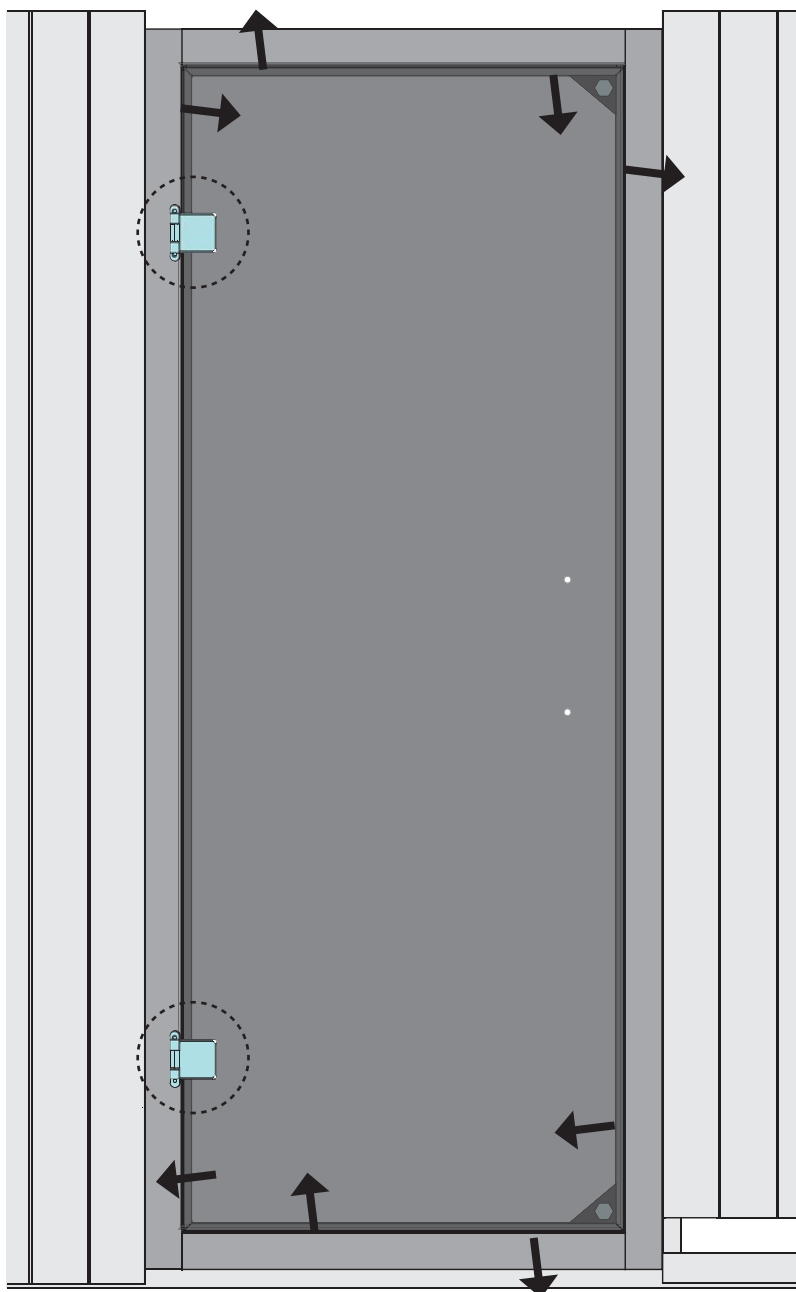

-  Außen: Metall
Innen: Holz
-  Outside: metal
Inside: wood
-  Extérieur: métal
Intérieur: bois
-  Buiten: metaal
Binnen: wood
-  Udenfor: metal
Inde: træ
-  Exterior: metal
Interior: madera
-  Esterno: metallo
Interno: legno
-  Venku: kov
Uvnitř: dřevo

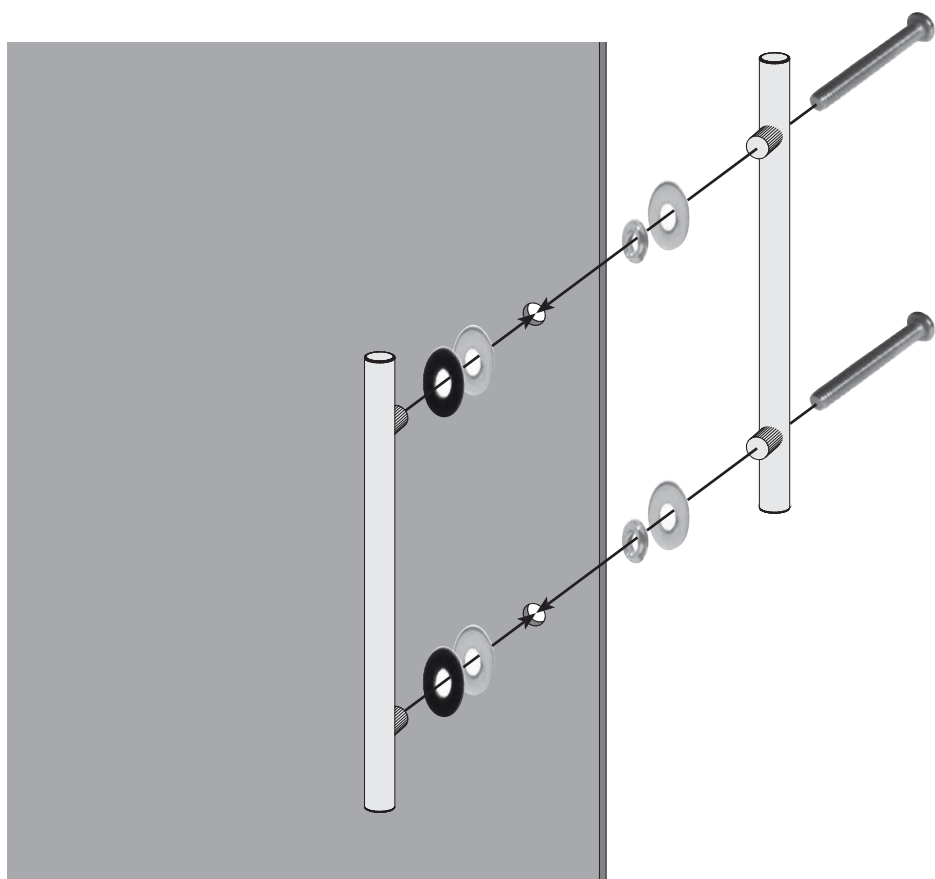
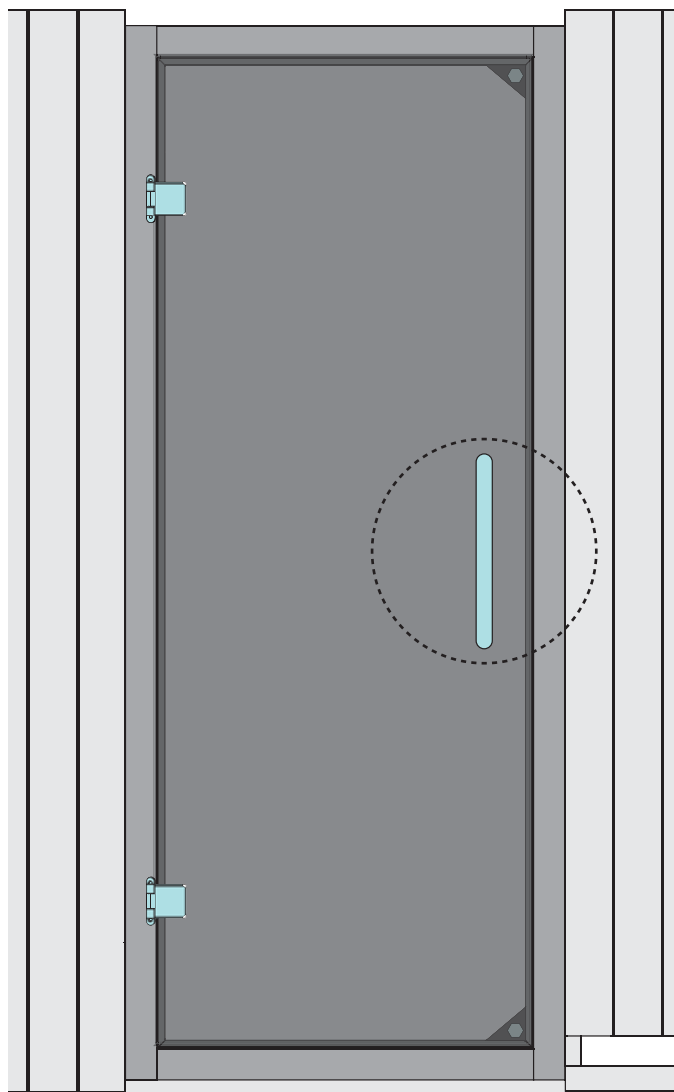

47372

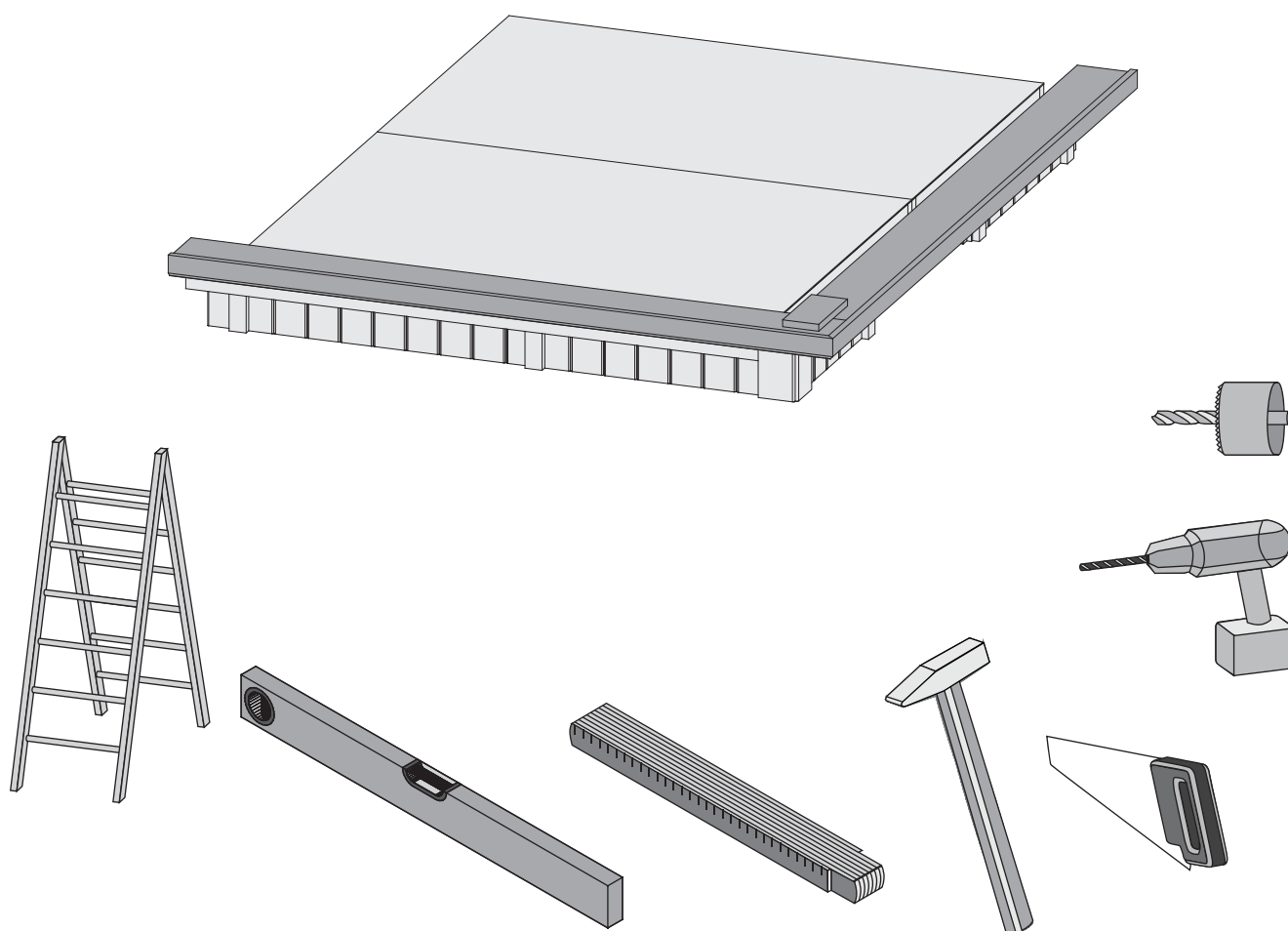

 **Aufbauanleitung**

 **Building Instructions**

 **notice de montage**

 **montagehandleiding**

 **Montagevejledning**

 **Instrucciones de construcción**

 **Istruzioni per il montaggio**

 **Montážní návod**





+49 421 38693 33

 Vergleichen Sie zuerst die Material-liste mit Ihrem Paketinhalte! Bitte haben Sie Verständnis, dass Beanstandungen nur im nicht aufgebauten Zustand bearbeitet werden können!

 Vergelijk eerst de lijst van materialen met de inhoud van uw pakket! Reclamaties kunnen alleen in behandeling worden genomen zolang de onderdelen nog niet zijn gemonteerd!

 Confrontate questa distinta materiali prima con il contenuto del pacchetto! Vi preghiamo di comprendere che eventuali reclami possono essere accolti solo prima del montaggio!

 First compare the list of materials with your package contents! Please understand that complaints can be processed in the non-built status only!

 Start med at kontrollere materialelisten med indholdet af den leverede pakke! Vi gør venligst opmærksom på at reklamationer kun kan behandles for materialer som ikke er blevet bearbejdet!

 Nejprve překontrolujte obsah balení podle materiálového listu! Mějte pochopení pro to, že případnou reklamaci se můžeme zabývat pouze tehdy, když díly nebudou smontované! Za pomoci tohoto seznamu můžete jednotlivé díly přiřadit k montážnímu návodu.

 Commencez par comparer la liste du matériel avec le contenu de votre paquet! Sachez que nous traitons uniquement les réclamations concernant le matériel à l'état non monté!

 En primer lugar, compare la lista de material con el contenido del paquete. Rogamos entienda que las reclamaciones sólo pueden ser tramitadas antes de montar el objeto!

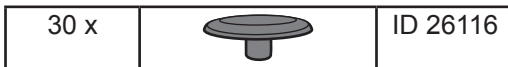
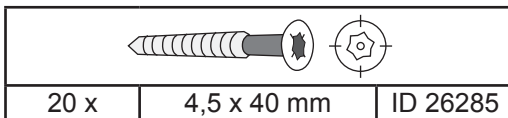
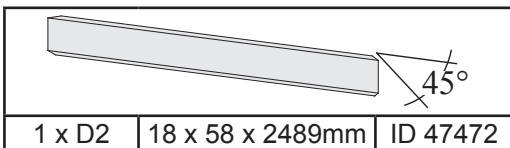
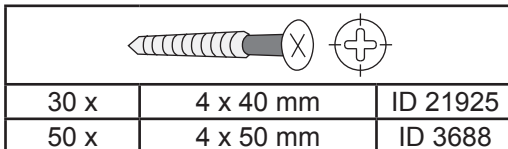
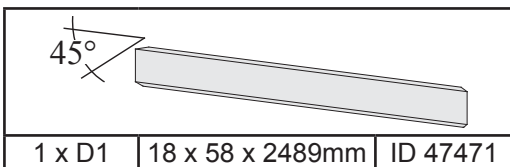
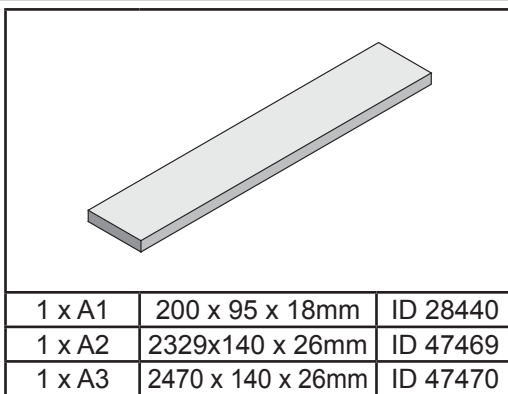
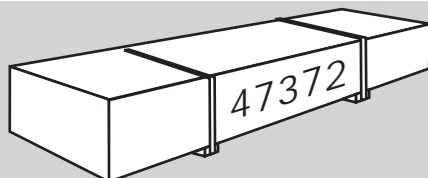

01

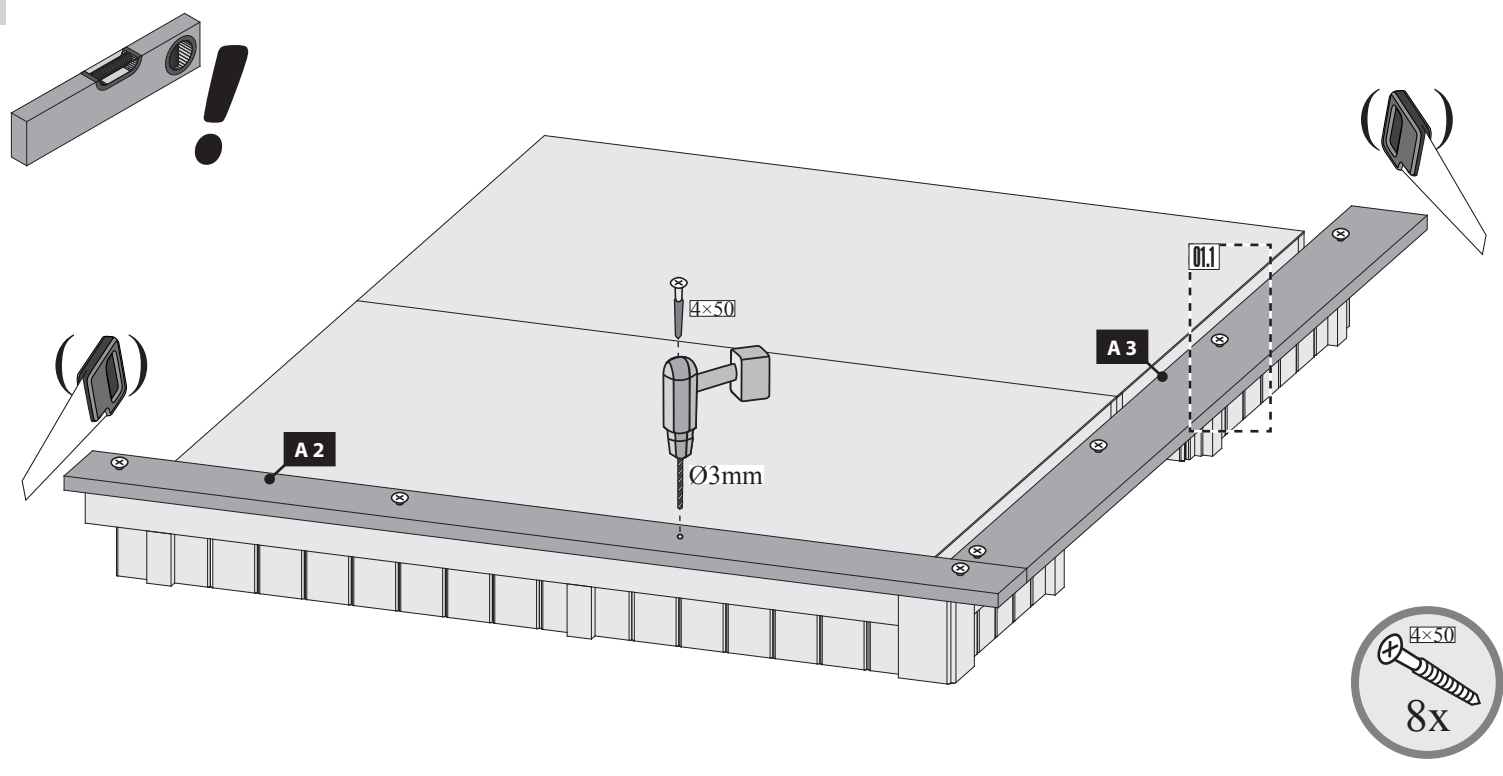

01.1

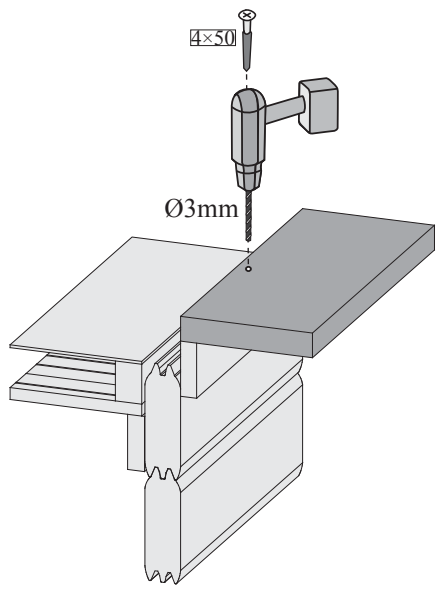

02.1

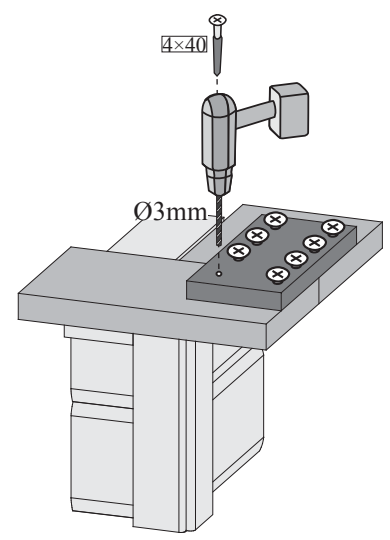

02

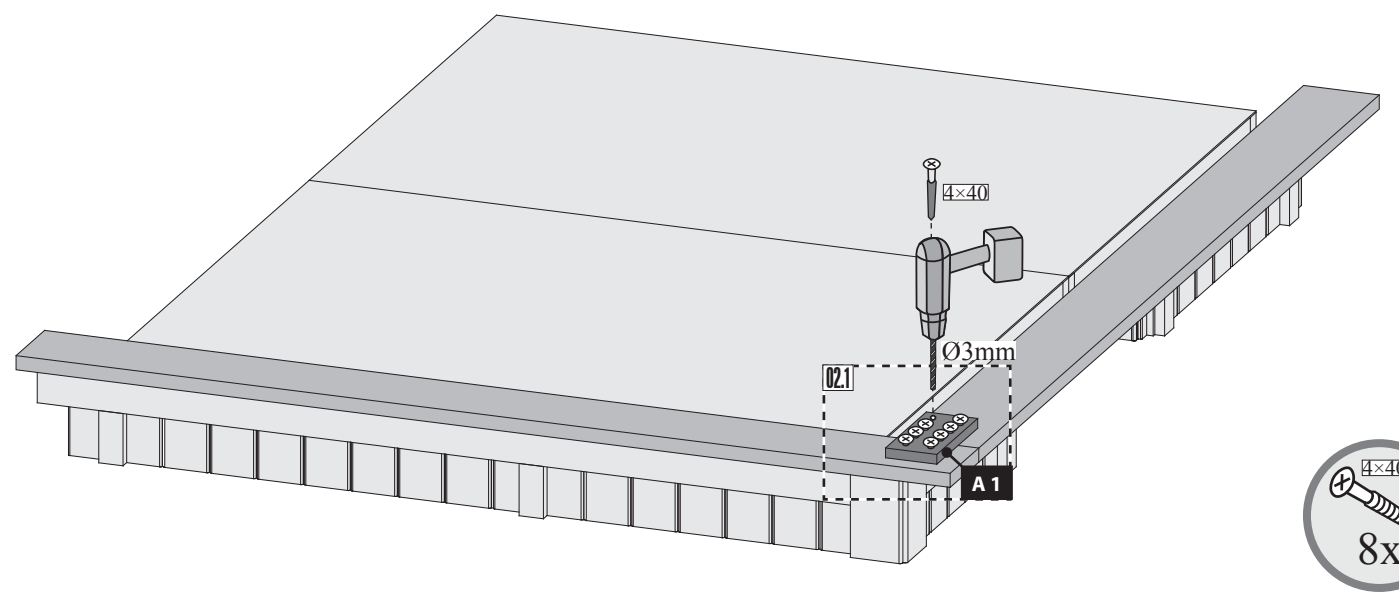

03

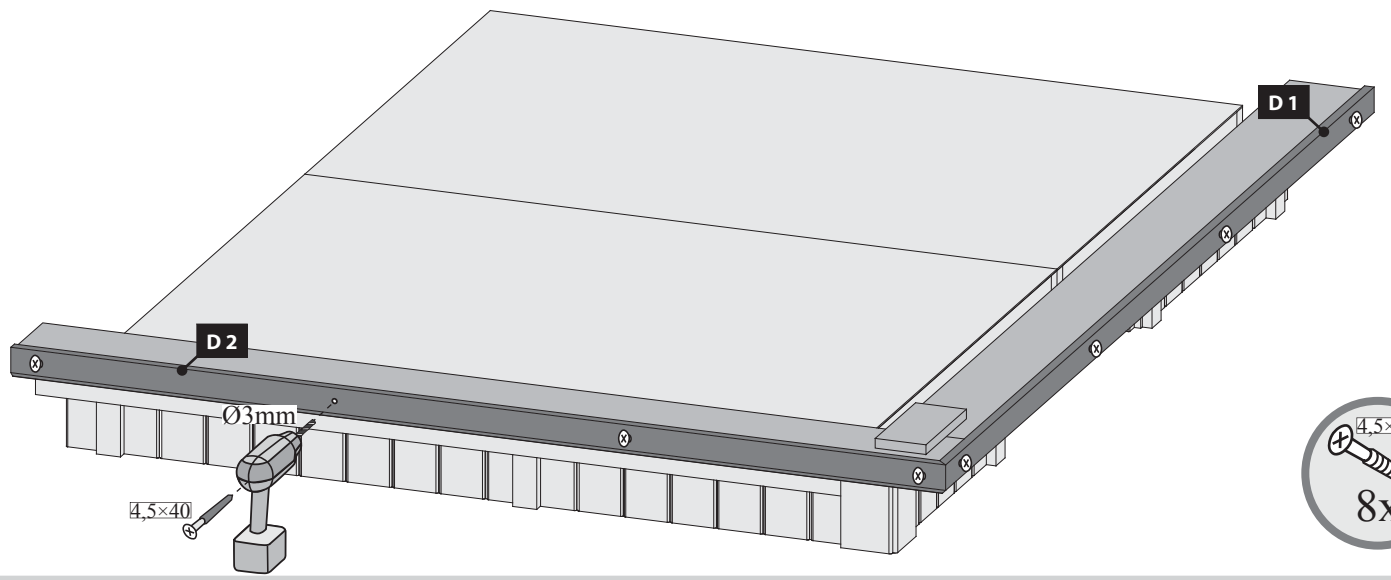

04

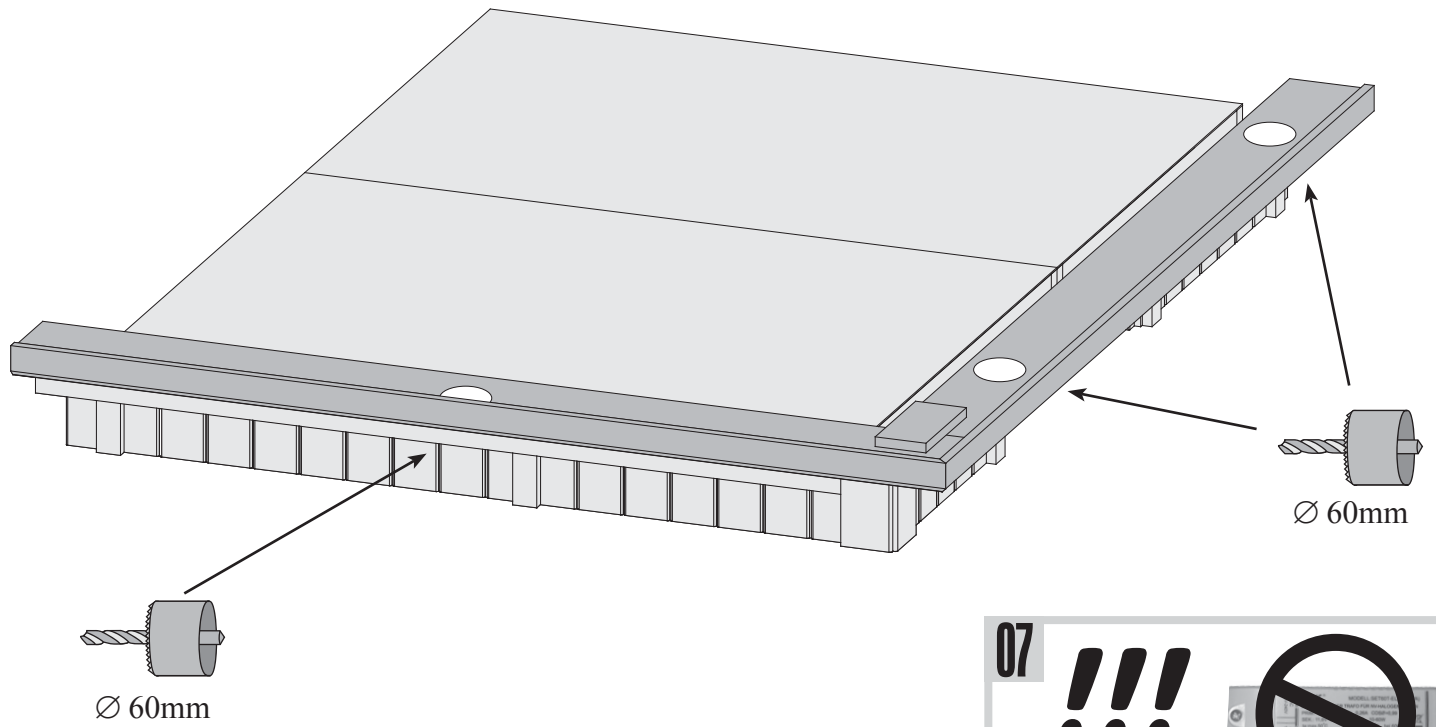

05

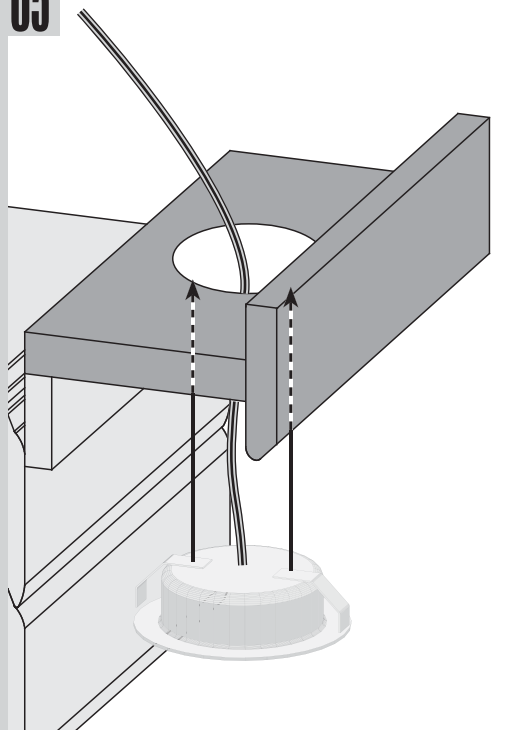

06

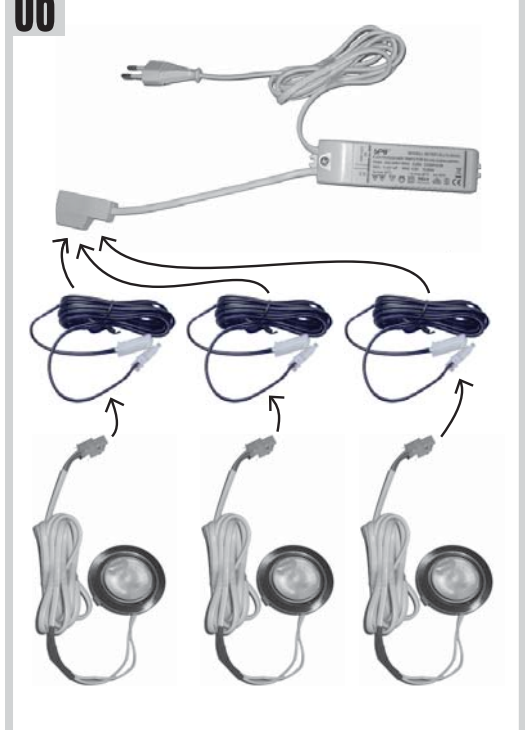

07

