

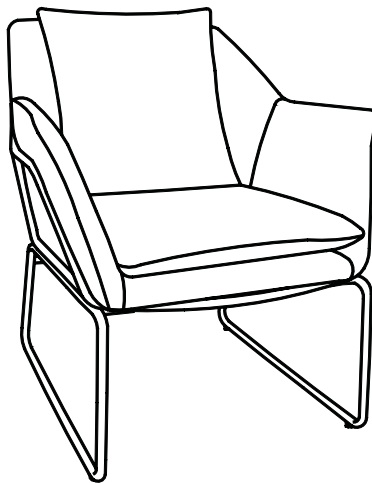

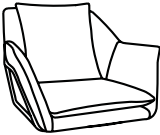

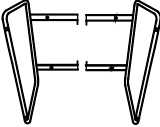





Montageanleitung
für
JOSIE Sessel

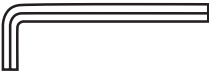

91349-91358

Nr.	Form	Anzahl
1		1
2		1
3	 <p data-bbox="650 560 796 587">M6x35MM</p>	4
4	 <p data-bbox="650 703 796 730">M8x20MM</p>	2
5	 <p data-bbox="751 847 796 874">M6</p>	4
6	 <p data-bbox="594 991 796 1018">M6x18x1.2MM</p>	4
7	 <p data-bbox="751 1139 796 1166">M8</p>	2
8	 <p data-bbox="751 1283 796 1310">M6</p>	1
9		1

1

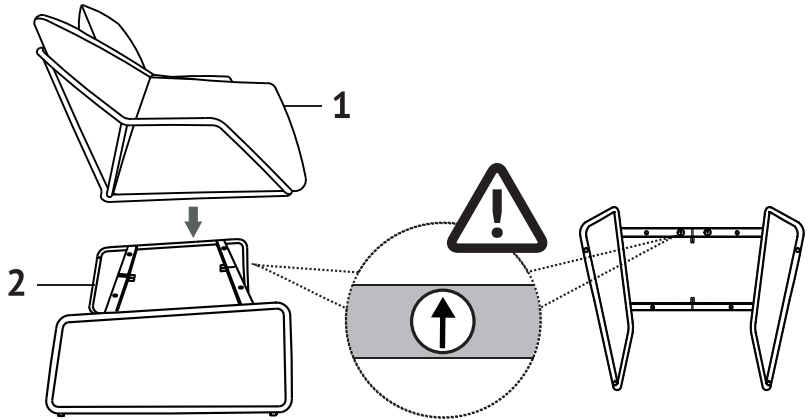

2

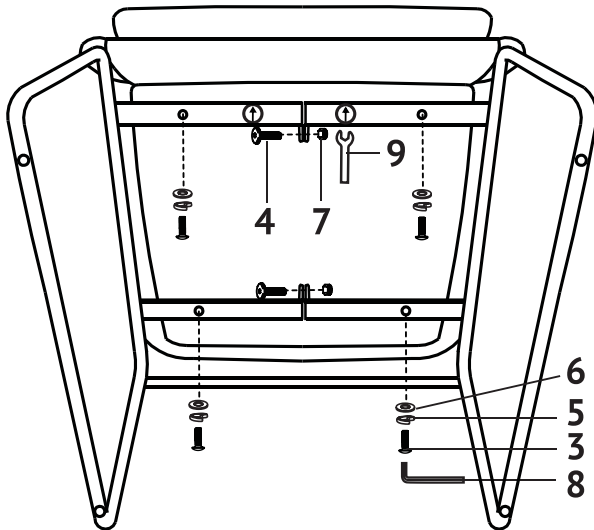

3

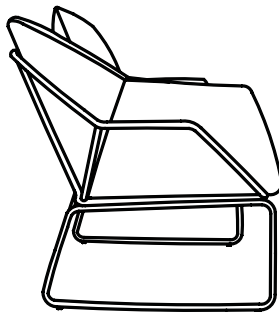



Vielen Dank für Ihren Einkauf!

**Falls Sie Unterstützung benötigen, können
Sie sich gerne an unser Service Team wenden:**

+49 2203 94 79 300
service@svita-shop.de
www.svita-shop.de

Clic-Trade GmbH
Stollwerckstr. 27-31
51149 Köln
www.clictrade.gmbh