



Focus on Furniture, Cherish for People

# Assembly Instructions

Focus on Furniture, Cherish for People



## CUSTOMER CARE

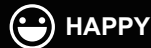

**HAPPY**

We're just happy cuz you're happy.  
If you don't know how to express your new-found joy, we can get a few suggestions.

**Tell** your family and friends.  
**Share** your experience by writing a review.



**NOT HAPPY**

Our friendly customer service team will work hard to make you have a big smile.

**Here's** how to contact us.  
✉ [official@mepplzian.com](mailto:official@mepplzian.com)

Mepplzian®

## NOTICE:

- › Basic precautions should always be followed when using this product. Please read all instructions before using the cabinet and retain the education for future reference.
- › Failure to observe all instructions and warnings may cause severe property damage or personal injuries.
- › When unpacking, please be careful don't cut too deep to damage the products in the box. Just use the blade to scratch the parcel tape.
- › Check the product and hardware accessories in the box; and confirm whether the instructions are complete.
- › When installing, please pay attention to the protection of the parts. The soft material must be placed under the product, and please carefully handle it to avoid surface damage.
- › After the assembly is completed, please adjust the placement position according to the actual situation.
- › Keep children away from cabinets, accessories, and installation tools. They are at risk of injury to the child.
- › Two people are recommended for assembly.
- › If you need the electronic manual, please contact our customer service to get it. (email: [official@mepplzian.com](mailto:official@mepplzian.com))

## RETURN/DAMAGE CLAIM INSTRUCTIONS:

- › The product is shipped in a single carton box. If you haven't received the package or need to know the tracking of the package, get in touch with us immediately via Amazon message or contact us email: [official@mepplzian.com](mailto:official@mepplzian.com).
- › If the package is damaged, please get in touch with us from the very beginning. Attaching a damaged photo is appreciated.
- › The product accepts returns within 30 days without any reason. If you return this item for personal reasons, you must cover the return fee and order processing fee (0- 20% restocking fee based on the invoice price). We will cover the freight if the product has quality issues (not caused by humans).
- › Please keep the original box if you need to return the goods. Please use our return label and do not return it without permission.
- › If you return the product after 30 days of receiving it, we are afraid your return application won't be accepted. We appreciate your understanding.
- › Any damages, defects and parts missings during installation, pls contact us from the very beginning. Replacement, exchange and refund will be arranged ASAP except of personal reasons.
- › Customer Service: [official@mepplzian.com](mailto:official@mepplzian.com).

## Part List



Open the package, and put the item on the mat with care. Please install it carefully to ensure your fingers will not be scratched.

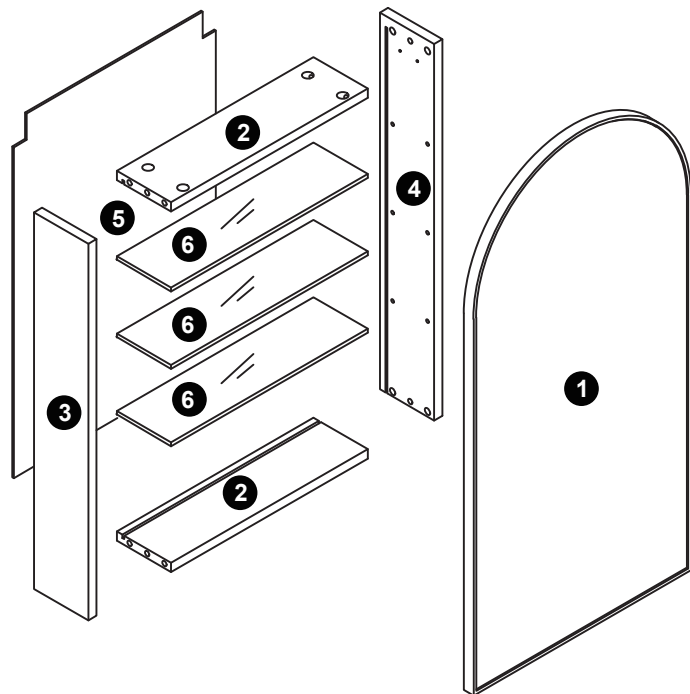

## Hardware List

**A**

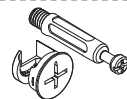

x8

**B**

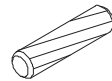

x4

**C**



x16

**D**

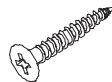

x4

**E**

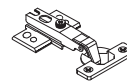

x2

**F**

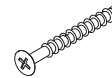

x4

**G**



x12

**H**

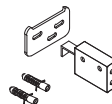

x2

**L**



x4

**M**



x4

**N**



x4

**Start...**

**| Step1**

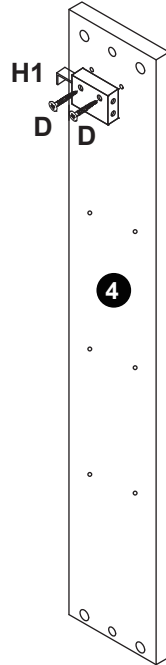
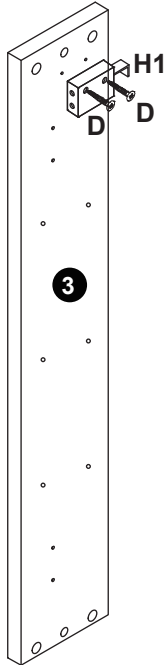
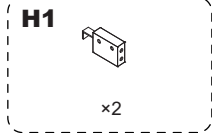
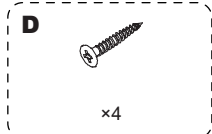

**| Step2**

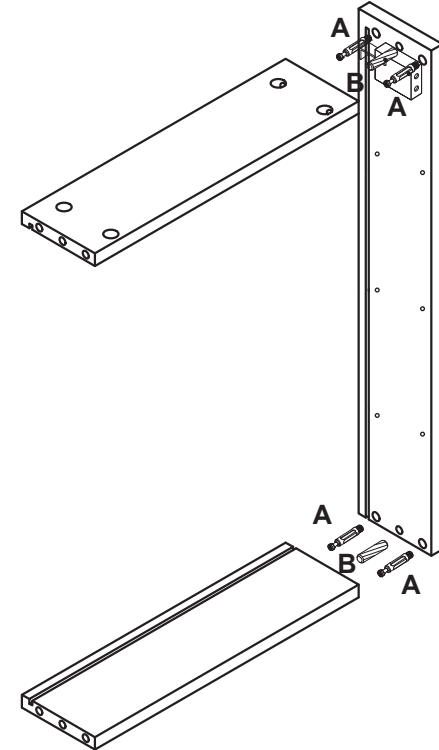
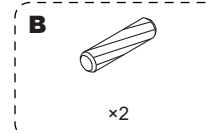
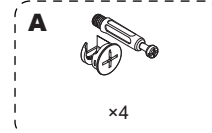

| Step3

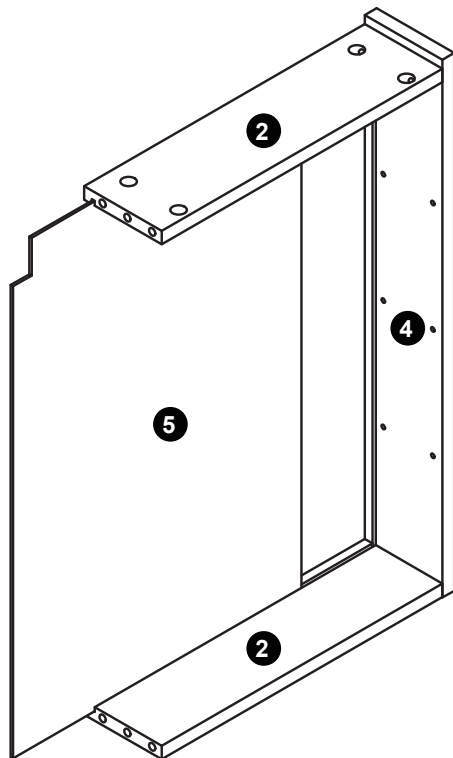

| Step4

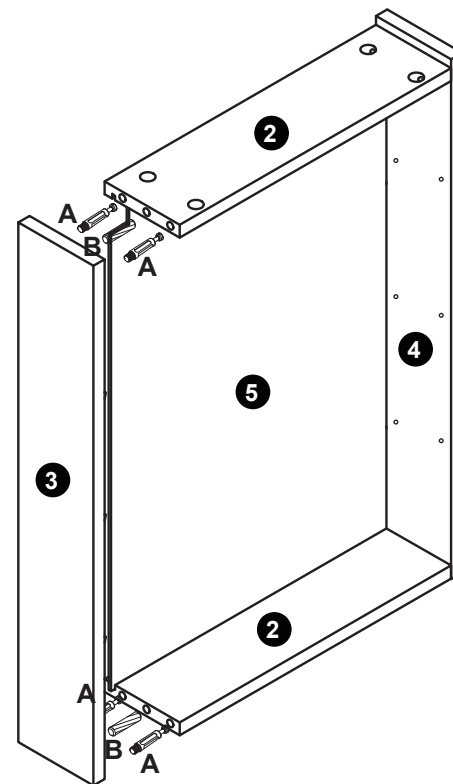
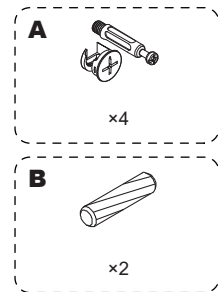

### | Step5

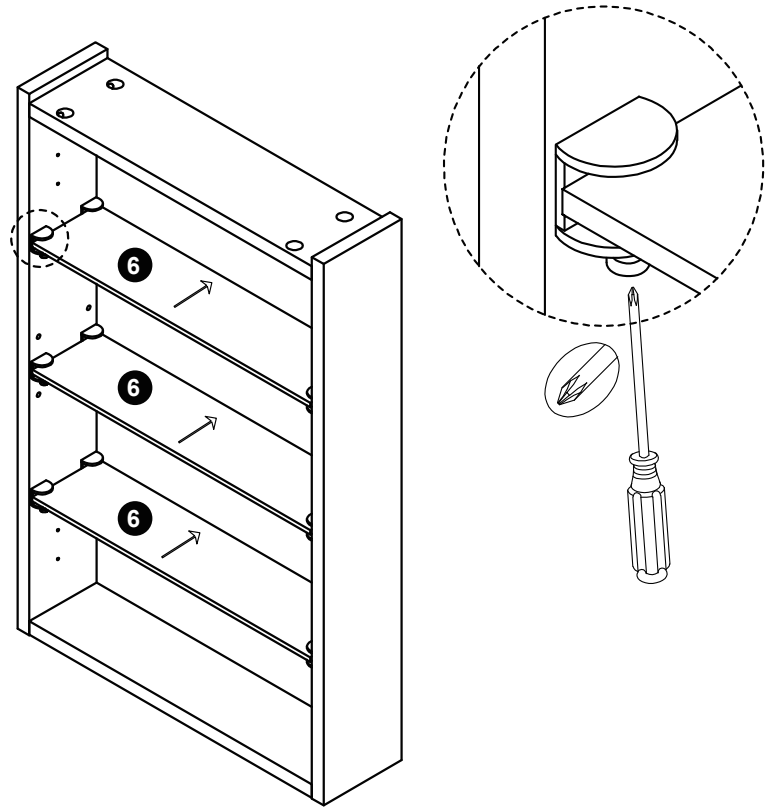

### | Step6

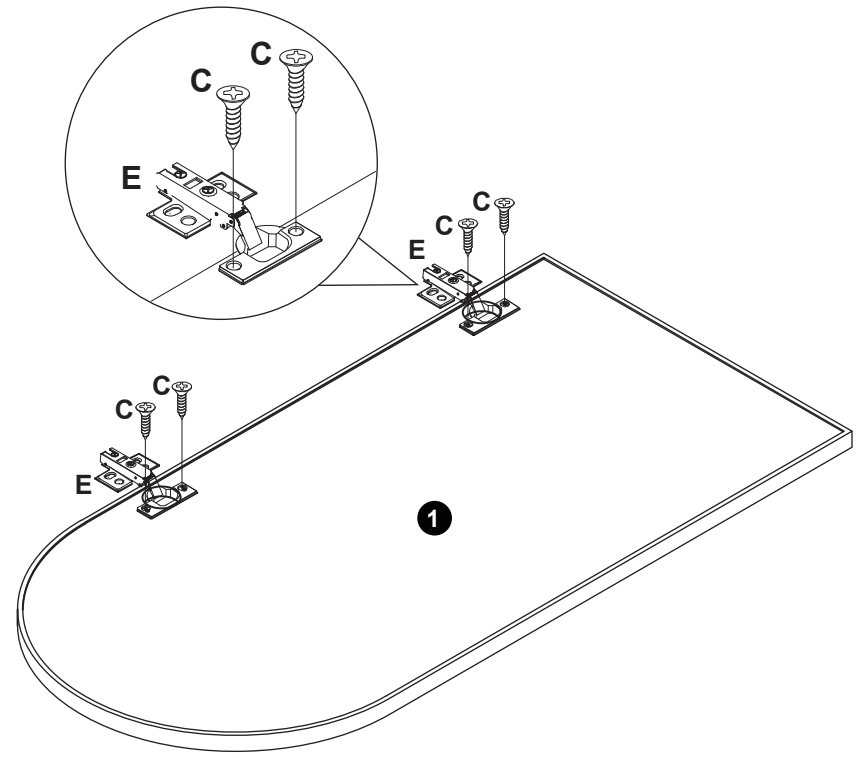
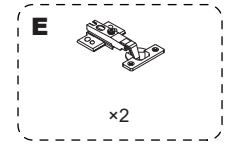
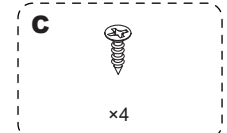

| Step 7

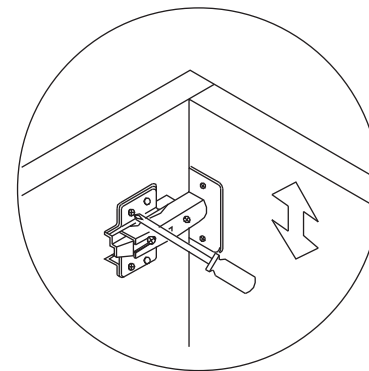
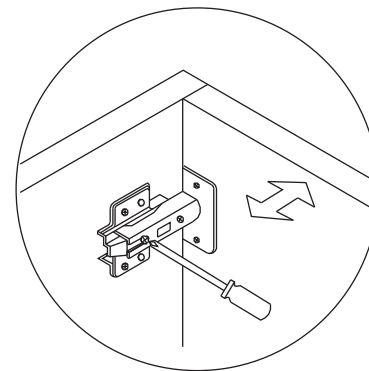
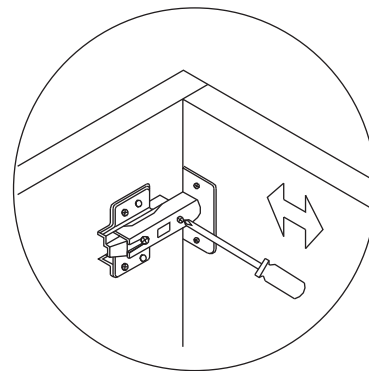
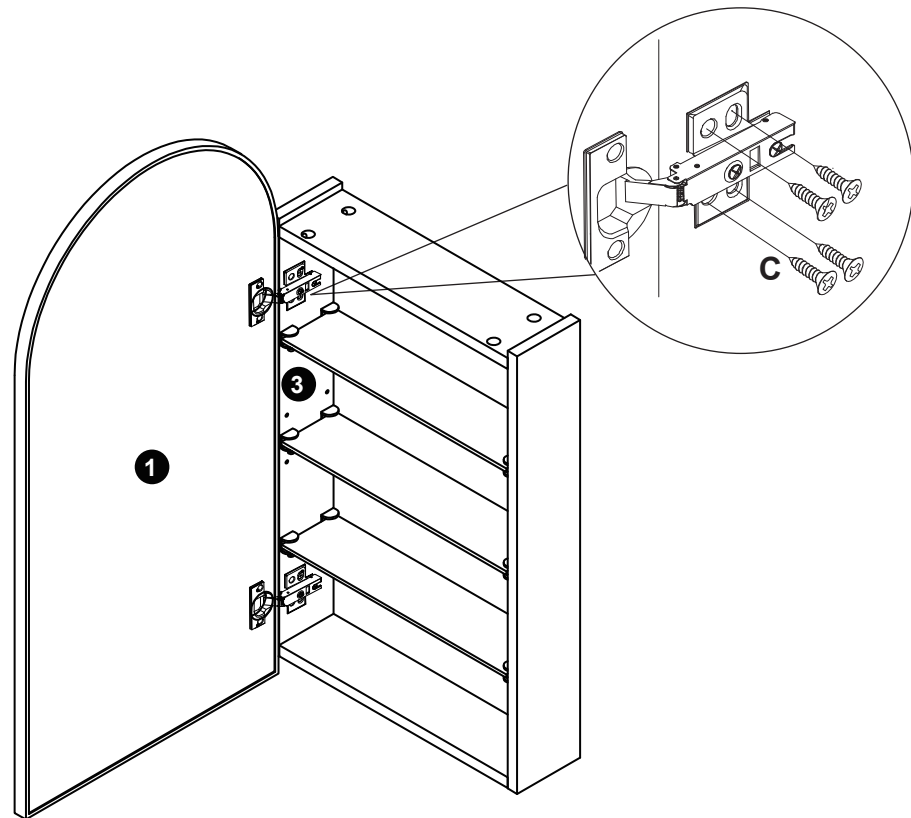
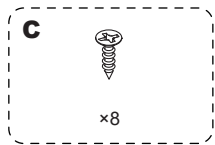

## | Step8

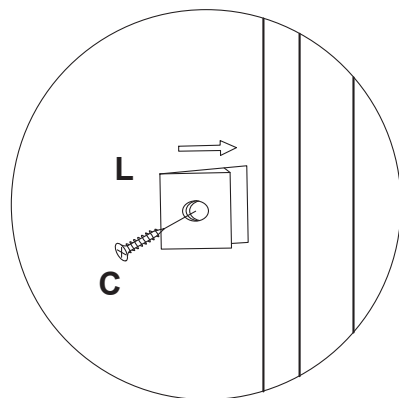
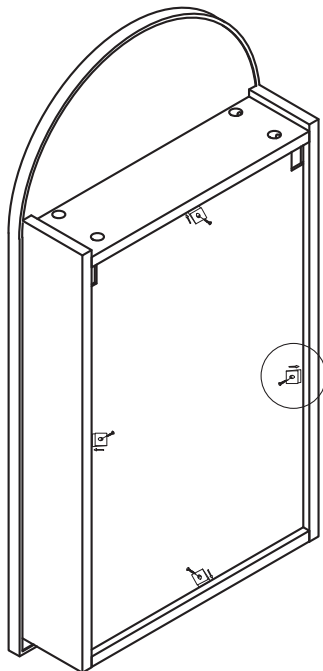
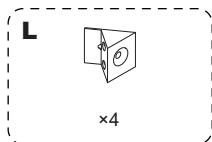
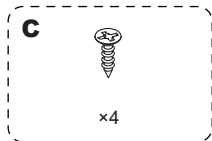

## | Step9-Optional for studs/concrete

**Attention:** Optional install on concrete or studs anchors

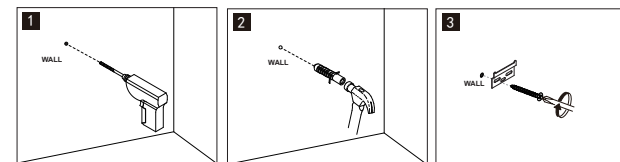
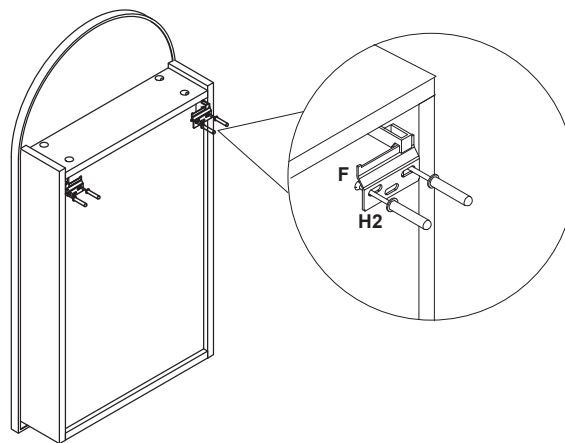
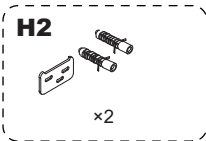
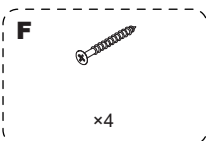

**Studs**

**Concrete**

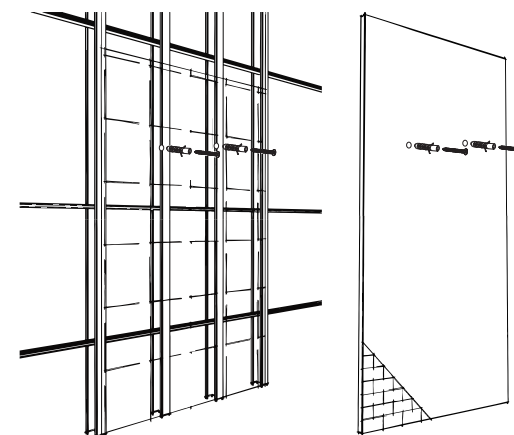



## | Step9-Optional for drywall

**Attention:** Optional install on drywall (sheet wood) please use drywall anchors

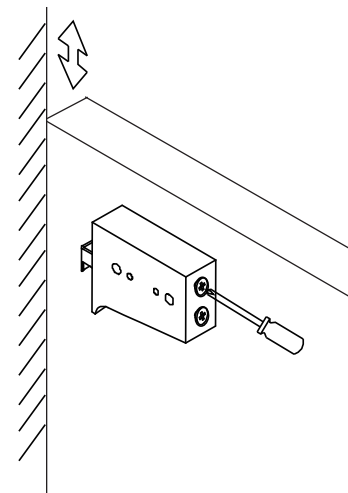
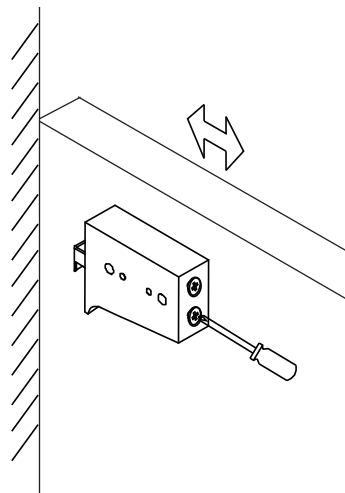
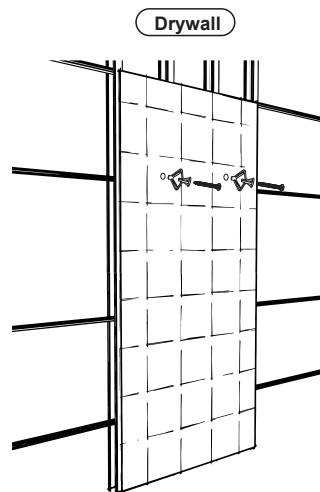
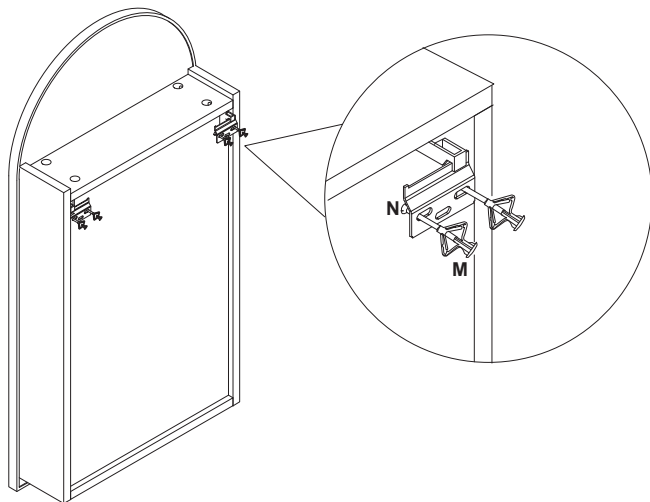
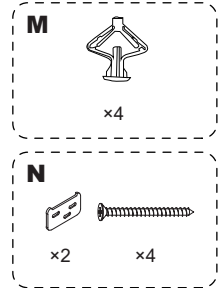
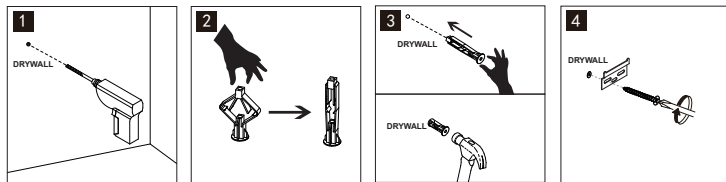

## About Meplzian

Meplzian has focused on household products design and research for many years. Professional design and warm-hearted service make each Meplzian staff believe that eco-friendly and cost-effective furniture make warmer home and better life.

**Focus on Furniture, Cherish for People**

**Customer Service: [official@meplzian.com](mailto:official@meplzian.com)**

The logo for Meplzian, featuring a stylized 'M' icon followed by the word 'meplzian' in a lowercase, sans-serif font, with a registered trademark symbol (®) to the upper right.

## LIMITED WARRANTY

Meplzian furniture team would like to improve customer service quality and make your experience smooth.

Return Policy: Meplzian accepts returns within 30 days without any significant reason. After we receive the returned item, we will check it and make sure that it is not damaged, then we will process the refund. For more details, please check the above terms of RETURN/DAMAGE CLAIM INSTRUCTIONS.

Any damages, defects and parts missings during installation, pls contact us from the very beginning. Replacement, exchange and refund will be arranged ASAP except of personal reasons.

The exceptions or exclusions to this warranty are as follows:

1. Meplzian does not accept claims outside of a limited period.
2. This warranty does not include the products purchased by mistake.
3. Any damages, broken, missing parts, Meplzian will repair or replace them without charging you any cost within a reasonable period.

We reserve the right to require damaged parts to be returned to us upon our request.

If you have any questions concerning this warranty, please get in touch with the Meplzian Customer Service department via Amazon message or [official@meplzian.com](mailto:official@meplzian.com). Be prepared to provide your name, address, daytime phone number, the product's model and purchase order number, the date of purchase, and the store name. All the information you provided will help us track your order quickly and solve your problem in the shortest time. This warranty gives you specific rights, and you still possess other rights that vary in each case.