

N625P191518E

N625P191519E

Product manual
Gebrauchsanweisung
Manuel du produit
Manual del producto
Manuale del prodotto

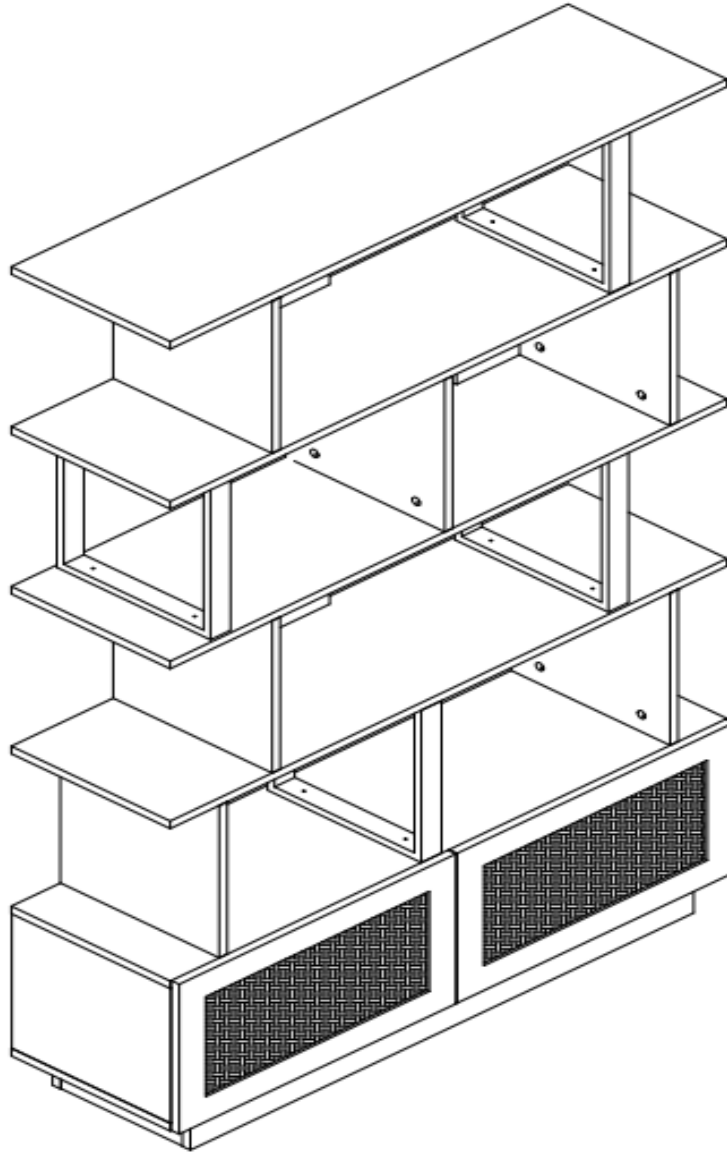











EN:Our product will be delivered to you in 2 packages.The delivery times of these 2 packages may differ,please be patient and thank you for your understanding

FR:Notre produit vous sera livré en 2 colis.Les delais de livraison de ces 2 colis peuvent différer,soyez patient et merci de votre compréhension.

DE:Unser Produkt wird Ihnen in 2 Paketen geliefert.Die Lieferzeiten dieser 2 Paketekonnenabweichen,bitte haben Sie etwas Geduld und vielen Dank fur Ihr Verstandnis

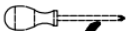
IT:I nostri prodotti vengono trasportati in due pacchetti. I tempi di consegna dei due pacchetti sono diversi: abbiate pazienza e vi ringrazio per la vostra comprensione.

ES:Nuestro producto se entrega en dos paquetes. El tiempo de entrega de estos dos paquetes es diferente. Por favor, sea paciente. Gracias por su comprensión.

 2PERS	 45 MIN	Tool Required Not Provided	
			
			



[DE]

Warnung: Lesen Sie die Anleitung vor dem Zusammenbau bitte vollständig durch. Überprüfen Sie, ob Sie alle auf den Seiten aufgeführten Komponenten und Werkzeuge haben.

Warnung: Legen Sie alle Teile auf eine ebene Fläche. Legen Sie eine weiche Decke oder Ähnliches darunter, um sie vor Kratzern oder Flecken zu schützen. Vermeiden Sie es, Komponenten über den Boden zu ziehen oder zu schieben.

Warnung: Überprüfen Sie regelmäßig alle Beschläge und Befestigungen, um sicherzustellen, dass sie sicher sind und um Unfälle zu vermeiden. Wenn Teile fehlen, kaputt, beschädigt oder abgenutzt sind, verwenden Sie das Produkt nicht weiter, bis es mit vom Hersteller autorisierten Teilen repariert wurde.

Warnung: Lassen Sie Kinder nicht auf die Möbel klettern, da dies zum Umkippen und zu schweren Verletzungen führen kann. Bauen Sie die Möbel außerhalb der Reichweite von Kindern zusammen.

Warnung: Stellen Sie die Möbel nicht in die Nähe von Feuerquellen oder heißen Gegenständen, um Brandgefahr zu vermeiden.

Warnung: Reinigen Sie die Möbel mit einem feuchten Tuch oder Alkohol. Verwenden Sie keine Reinigungsmittel mit ätzenden Chemikalien.

Warnung: Dieses Produkt ist mit einer Kippschutzvorrichtung ausgestattet. Bitte installieren Sie diese Vorrichtung unbedingt, um unnötige Verletzungen durch Umkippen zu vermeiden.

[EN]

Warning: Please read instructions fully before starting assembly. Check you have all the components and tools listed on pages.

Warning: Please place all parts on a flat surface. Place a soft blanket or similar underneath to protect against scratches or stains. Avoid dragging or sliding components across the floor.

Warning: Regularly check all fittings and fastenings to ensure they are secure and to prevent accidents. If any parts are missing, broken, damaged, or worn, discontinue use of the product until repairs have been made using factory authorized parts.

Warning: Do not allow children to climb on the furniture as this may result in tipping and serious personal injury. Assemble the furniture away from the reach of children.

Warning: Do not place furniture close to fire sources or high-temperature objects to avoid the risk of fire.

Warning: Clean furniture with a damp cloth or alcohol, avoid using cleaning agents containing corrosive chemicals.

Warning: This product is equipped with an anti-tilt device. Please be sure to install this device to prevent unnecessary injuries caused by tipping.

[FR]

Avertissement : Veuillez lire entièrement les instructions avant de commencer l'assemblage. Vérifiez que vous disposez de tous les composants et outils répertoriés sur les pages.

Avertissement : Veuillez placer toutes les pièces sur une surface plane. Placez une couverture douce ou similaire en dessous pour les protéger des rayures ou des taches. Évitez de faire glisser les composants sur le sol.

Avertissement : Vérifiez régulièrement tous les raccords et fixations pour vous assurer qu'ils sont bien fixés et pour éviter les accidents. Si des pièces manquent, sont cassées, endommagées ou usées, cessez d'utiliser le produit jusqu'à ce que des réparations aient été effectuées à l'aide de pièces autorisées par l'usine.

Avertissement : Ne laissez pas les enfants grimper sur les meubles car cela pourrait entraîner un basculement et des blessures graves. Assemblez les meubles hors de portée des enfants.

Avertissement : Ne placez pas les meubles à proximité de sources de feu ou d'objets à haute température pour éviter tout risque d'incendie.



Avertissement : Nettoyez les meubles avec un chiffon humide ou de l'alcool, évitez d'utiliser des produits de nettoyage contenant des produits chimiques corrosifs.

Avertissement : Ce produit est équipé d'un dispositif anti-basculement. Assurez-vous d'installer ce dispositif pour éviter les blessures inutiles causées par un basculement.

[IT]

Attenzione: leggere attentamente le istruzioni prima di iniziare il montaggio. Verificare di avere tutti i componenti e gli strumenti elencati nelle pagine.

Attenzione: posizionare tutte le parti su una superficie piana. Posizionare una coperta morbida o simile sotto per proteggere da graffi o macchie. Evitare di trascinare o far scivolare i componenti sul pavimento.

Attenzione: controllare regolarmente tutti i raccordi e i dispositivi di fissaggio per assicurarsi che siano sicuri e per prevenire incidenti. Se alcune parti sono mancanti, rotte, danneggiate o usurate, interrompere l'uso del prodotto fino a quando non siano state eseguite le riparazioni utilizzando parti autorizzate dalla fabbrica.

Attenzione: non consentire ai bambini di arrampicarsi sui mobili poiché ciò potrebbe causare ribaltamenti e gravi lesioni personali. Montare i mobili lontano dalla portata dei bambini.

Attenzione: non posizionare i mobili vicino a fonti di fuoco o oggetti ad alta temperatura per evitare il rischio di incendio.

Attenzione: pulire i mobili con un panno umido o alcol, evitare di utilizzare detergenti contenenti sostanze chimiche corrosive.

Attenzione: questo prodotto è dotato di un dispositivo antiribaltamento. Assicurarsi di installare questo dispositivo per prevenire lesioni inutili causate dal ribaltamento.

[ES]

Advertencia: Lea las instrucciones completamente antes de comenzar el montaje. Compruebe que tiene todos los componentes y herramientas que se enumeran en las páginas.

Advertencia: Coloque todas las piezas sobre una superficie plana. Coloque una manta suave o algo similar debajo para protegerlas de rayones o manchas. Evite arrastrar o deslizar los componentes por el piso.

Advertencia: Verifique regularmente todos los accesorios y fijaciones para asegurarse de que estén seguros y evitar accidentes. Si falta alguna pieza, está rota, dañada o desgastada, deje de usar el producto hasta que se hayan realizado las reparaciones con piezas autorizadas de fábrica.

Advertencia: No permita que los niños se suban a los muebles, ya que esto puede provocar que se vuelquen y lesiones personales graves. Monte los muebles fuera del alcance de los niños.

Advertencia: No coloque los muebles cerca de fuentes de fuego u objetos de alta temperatura para evitar el riesgo de incendio.

Advertencia: Limpie los muebles con un paño húmedo o alcohol, evite usar agentes de limpieza que contengan químicos corrosivos.

Advertencia: Este producto está equipado con un dispositivo antivuelco. Asegúrese de instalar este dispositivo para evitar lesiones innecesarias causadas por vuelcos.

Importeur	Decobus Handel GmbH
Adresse	Innungsstraße 9, 21244 Buchholz, Deutschland
URL	https://www.decobusgroup.de
Hersteller	SHOUGUANG BOMAO TRADING CO.,LTD
Adresse	200 METERS SOUTH OF THE VILLAGE OFFICE OF DONGQL, SHENGCHENG STREET,SHOU GUANG CITY,SHANDONG.CHINA
Email/URL	https://bomaotrading.en.alibaba.com



Decobus Handel GmbH

Innungsstraße 9,

21244 Buchholz, Deutschland

<https://www.decobusgroup.de>

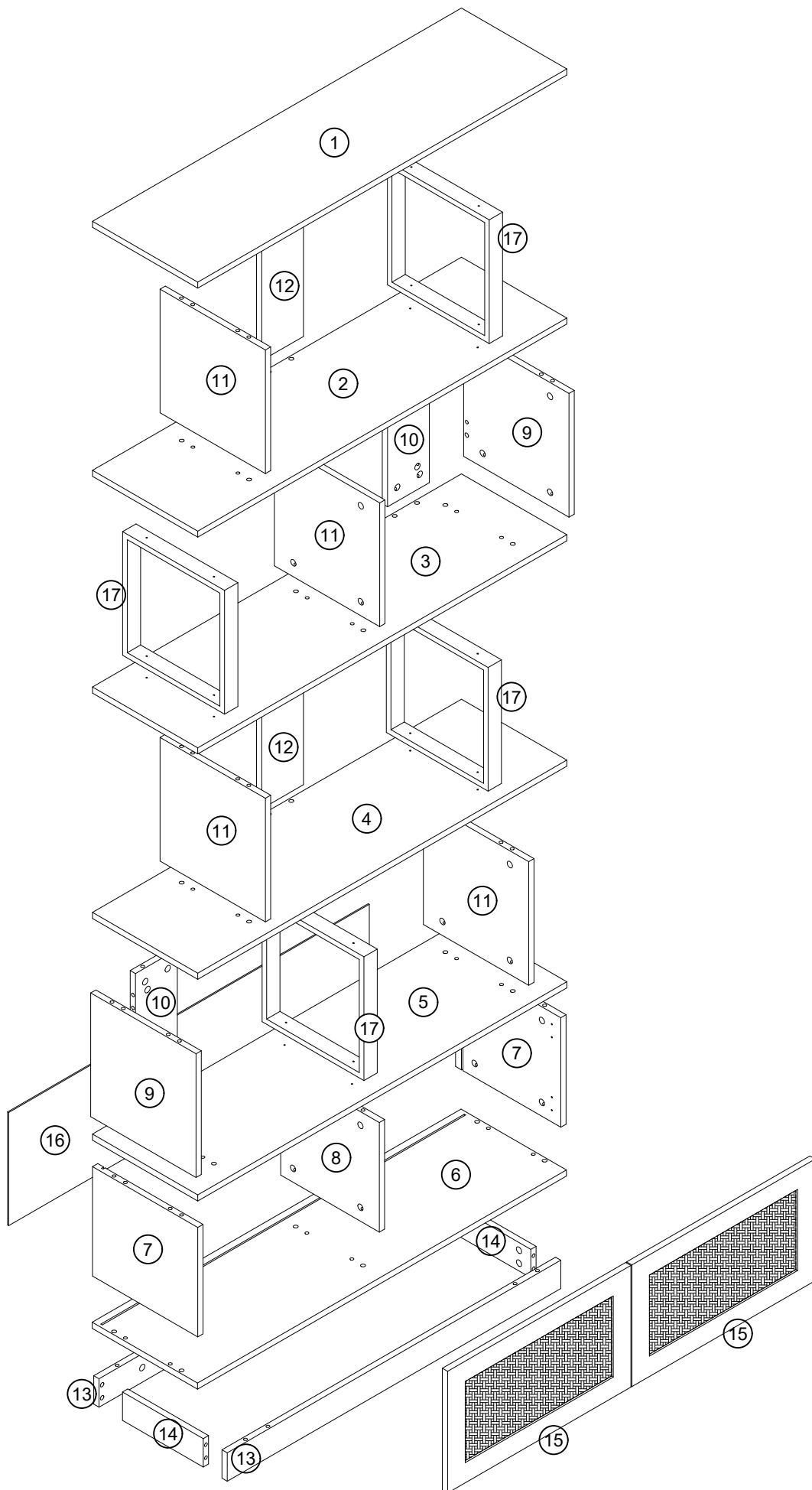

N625P191518E

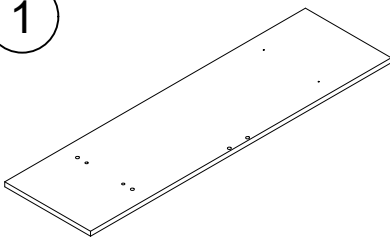
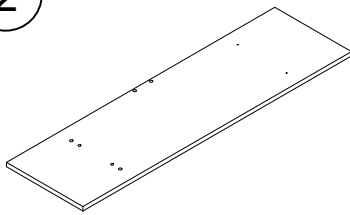
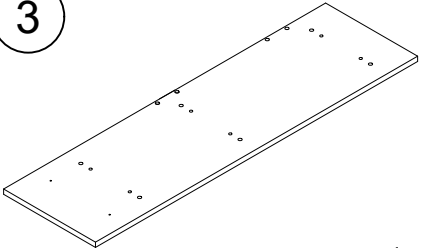
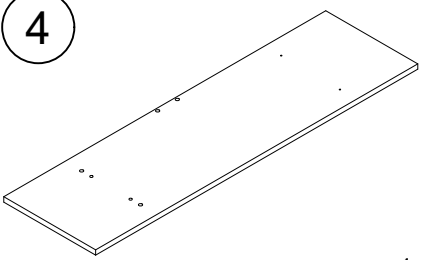
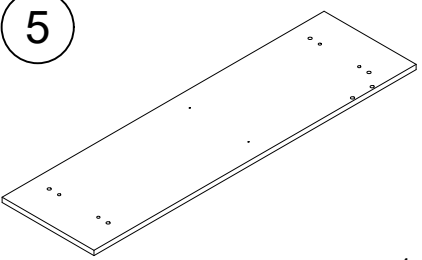
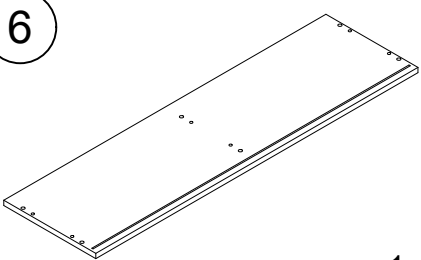
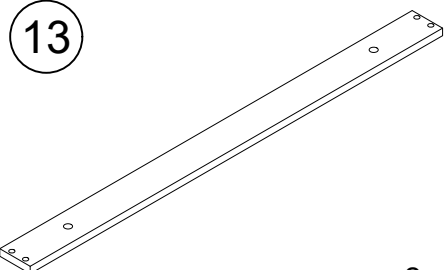
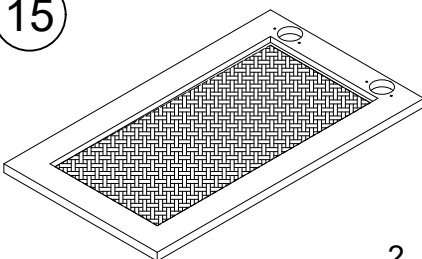
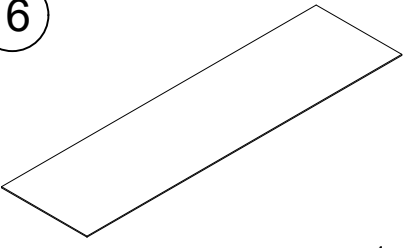
<p>①</p>  <p>1</p>	<p>②</p>  <p>1</p>	<p>③</p>  <p>1</p>
<p>④</p>  <p>1</p>	<p>⑤</p>  <p>1</p>	<p>⑥</p>  <p>1</p>
<p>⑬</p>  <p>2</p>	<p>⑮</p>  <p>2</p>	<p>⑯</p>  <p>1</p>

N625P191519E

7

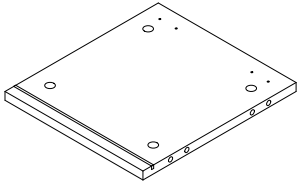

2

8

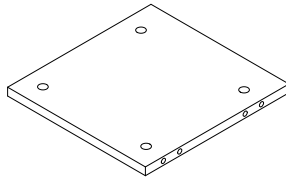

1

9

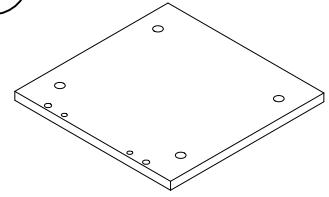

2

10

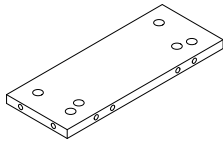

2

11

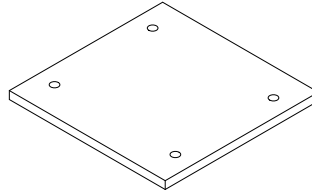

4

12

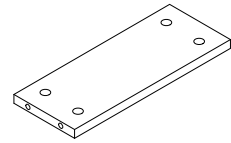

2

17

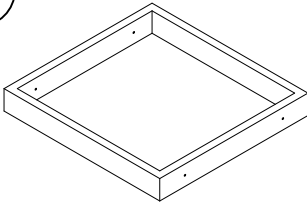

4

14

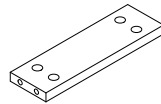

2

Hardware Box
Ein metallkästchen

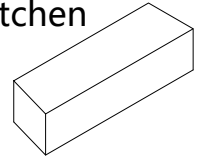

N625P191519E

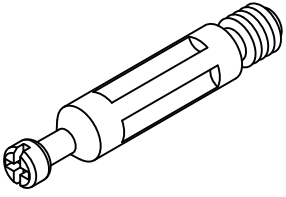
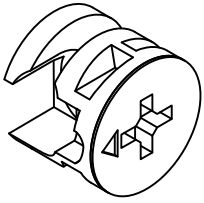
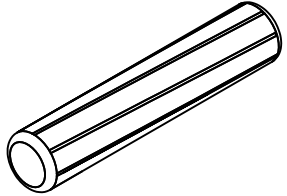
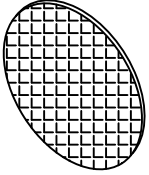
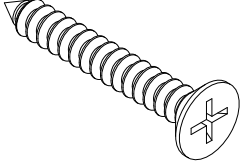
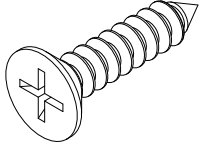
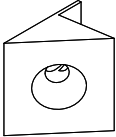
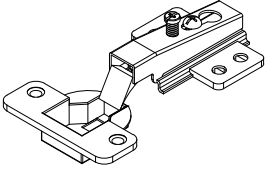
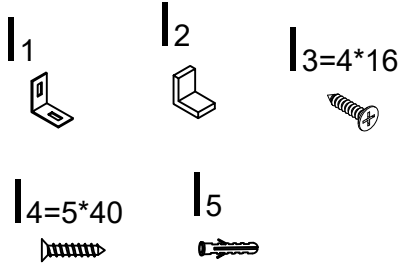
<p>A</p>  <p>$\Phi 6 \times 40 \text{MM}$ 68 pcs</p>	<p>B</p>  <p>$\Phi 15 \times 10 \text{MM}$ 68 pcs</p>	<p>C</p>  <p>$\Phi 8 \times 40 \text{MM}$ 44 pcs</p>
<p>D</p>  <p>$\phi 20$ 68 pcs</p>	<p>E</p>  <p>M4 X25 mm 16 pcs</p>	<p>F</p>  <p>M3.5 X14 mm 30</p>
<p>G</p>  <p>6 pcs</p>	<p>H</p>  <p>4 pcs</p>	<p>I</p> <p>pcs</p>  <p>I₁ I₂ I₃=4*16 I₄=5*40 I₅ 2PCS</p>

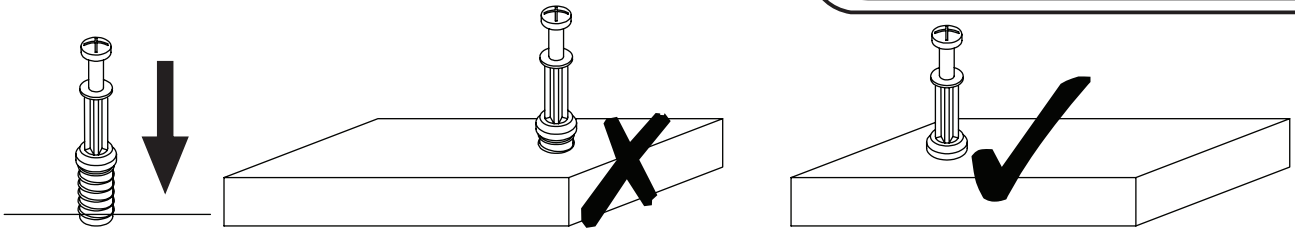

EN_QUICKFIT: Tighten quickfit until shoulder is flush with panel. Do not overtighten or undertighten.

FR_RACCORD RAPIDE: Faites serrer le raccord rapide jusqu'à ce que l'épaulement soit parfaitement encastré dans le panneau. Il ne faut ni trop serrer ni insuffisamment serrer.

ES_QUICKFIT: Apriete quickfit hasta que el hombro se descargue con el panel. NO lo sobreapriete ni lo apriete poco.

DE_QUICKFIT: Ziehen Sie den Quickfit fest, bis die Schulter mit der Platte bündig ist. Bitte nicht zu fest oder zu schwach anziehen.

IT_MONTAGGIO RAPIDO: Stringere il montaggio rapido fino a quando la spalla è a filo con il pannello, non stringere troppo o troppo poco.

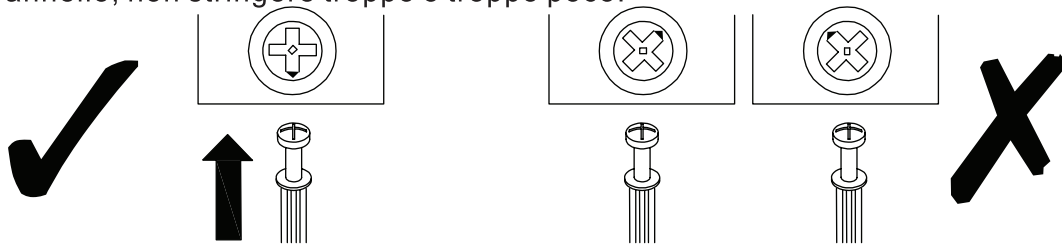

EN_CAM LOCK: When fitting cam lock, ensure starting position is correct before you insert connecting quickfit.

FR_SERRURE BATTEUSE: Avant d'insérer la serrure batteuse, veillez à la bonne orientation avant d'insérer le raccord rapide.

ES_CIERRE DE LA CÁMARA: Cuando instale el cierre de la cámara, asegúrese de que la posición de inicio es correcta antes de que inserte el quickfit conector.

DE_CAM-LOCK: Achten Sie bei der Montage des Cam-Locks auf die richtige Ausgangsposition, bevor Sie den Quickfit einsetzen.

IT_BLOCCAGGIO A CAMMA: Quando si monta il bloccaggio a camma, assicurarsi che la posizione iniziale sia corretta prima di inserire il montaggio rapido di collegamento.

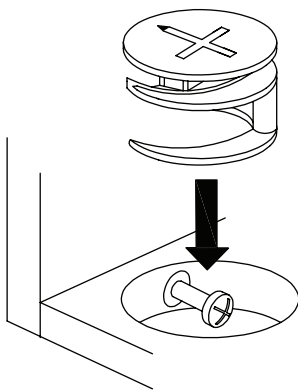

EN_Quickfit head should be in the centre of the cam lock when the two panels are joined.

Cam lock should be inserted before quickfit.

FR_Lorsque les deux panneaux sont assemblés, la tête du raccord rapide doit reposer au centre de la serrure batteuse. Il faut insérer la serrure batteuse avant le raccord rapide.

ES_El cabezal del quickfit debe estar en el centro del cierre de la cámara cuando se unan los dos paneles.

Se debe insertar el cierre de la cámara antes que el quickfit.

DE_Der Quickfit-Kopf sollte sich in der Mitte des Cam-Locks befinden, wenn die beiden Platten zusammengefügt sind. Der Cam-Lock sollte vor dem Quickfit eingesetzt werden.

IT_La testa del montaggio rapido deve trovarsi al centro del bloccaggio a camma quando i due pannelli sono uniti.

Il Bloccaggio a Camma deve essere inserito prima del montaggio rapido.

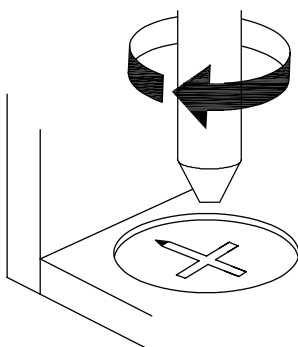

EN_Turn cam lock clockwise to tighten.

FR_Faites tourner la serrure batteuse dans le sens des aiguilles d'une montre pour la resserrer.

ES_Gire el cierre de la cámara en sentido horario para apretarlo.

DE_Drehen Sie den Cam-Lock im Uhrzeigersinn, um ihn festzuziehen.

IT_Ruotare il bloccaggio a camma in senso orario per stringere.

EN It may be necessary to adjust the hinges so that the doors align. Use the instructions below as a guide.

FR Il est parfois nécessaire d'ajuster les charnières pour un meilleur alignement des portes. Servez-vous des instructions ci-dessous comme guide.

ES Puede que sea necesario ajustar los quicios de forma que se alineen las puertas. Use las instrucciones que aparecen debajo como guía.

DE Möglicherweise müssen Sie die Scharniere so einstellen, dass die Türen ausgerichtet sind. Verwenden Sie die nachstehenden Anweisungen als Leitfaden.

IT Potrebbe essere necessario regolare le cerniere in modo che le porte siano allineate. Per fare ciò attenersi alle istruzioni sottostanti.

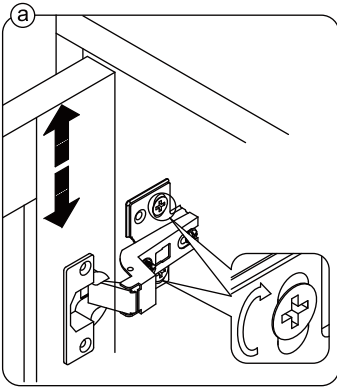

EN To adjust the door vertically loosen the screw as shown and move up and down as needed.

FR Si vous souhaitez régler la porte **verticalement**, desserrez la vis comme indiqué et déplacez la porte de haut en bas selon les besoins.

ES Para ajustar la puerta **verticalmente** afloje el tornillo tal y como se muestra y muévelo hacia arriba o hacia abajo según sea necesario.

DE Um die Tür **vertikal** auszurichten, lösen Sie die Schraube wie abgebildet und bewegen Sie sie nach Bedarf nach oben oder nach unten.

IT Per allineare la porta **verticalmente** allentare la vite come mostrato e spostarla in alto o in basso secondo necessità.

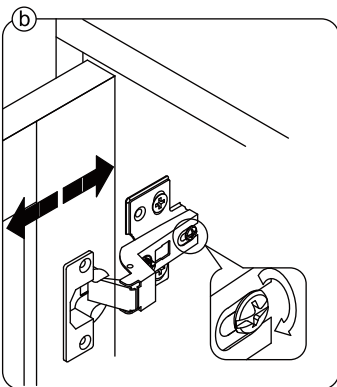

EN To adjust the gap from the door to the main frame turn the screw clockwise or anti-clockwise as needed.

FR Si vous souhaitez ajuster l'**écart** entre la porte et le cadre principal, tournez la vis dans le sens des aiguilles d'une montre ou dans le sens inverse, si nécessaire.

ES Para ajustar el **espacio** desde la puerta al marco principal, gire el tornillo en sentido horario o antihorario, según se necesite.

DE Um den **Abstand** von der Tür zum Hauptrahmen auszurichten, drehen Sie die Schraube je nach Bedarf im oder gegen den Uhrzeigersinn.

IT Per regolare lo **spazio** tra la porta e il telaio principale, avvitare o svitare la vite secondo necessità.

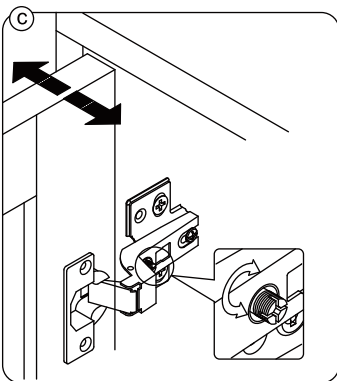

EN To adjust the door laterally adjust the screw as shown by turning clockwise or anti-clockwise.

FR Si vous souhaitez ajuster la porte **latéralement**, ajustez la vis comme indiqué en tournant dans le sens des aiguilles d'une montre ou dans le sens inverse des aiguilles d'une montre.

ES Para ajustar la puerta **lateralmente** ajuste el tornillo tal y como se muestra girándolo en sentido horario y antihorario.

DE Um die Tür **seitlich** auszurichten, stellen Sie bitte die Schraube wie abgebildet durch Drehen im oder gegen den Uhrzeigersinn ein.

IT Per allineare la porta **lateralmente** regolare la vite come mostrato, avvitarandola o svitarandola.

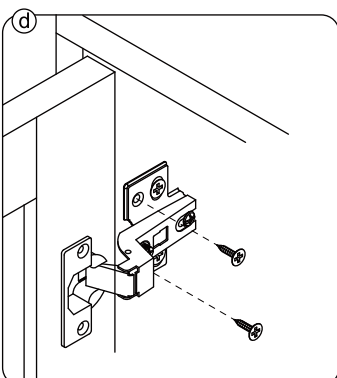

EN Please fix other screws

FR Merci de serrer les autres vis.

ES Fije los demás tornillos

DE Befestigen Sie bitte die anderen Schrauben

IT Fissare le altre viti

Step 1

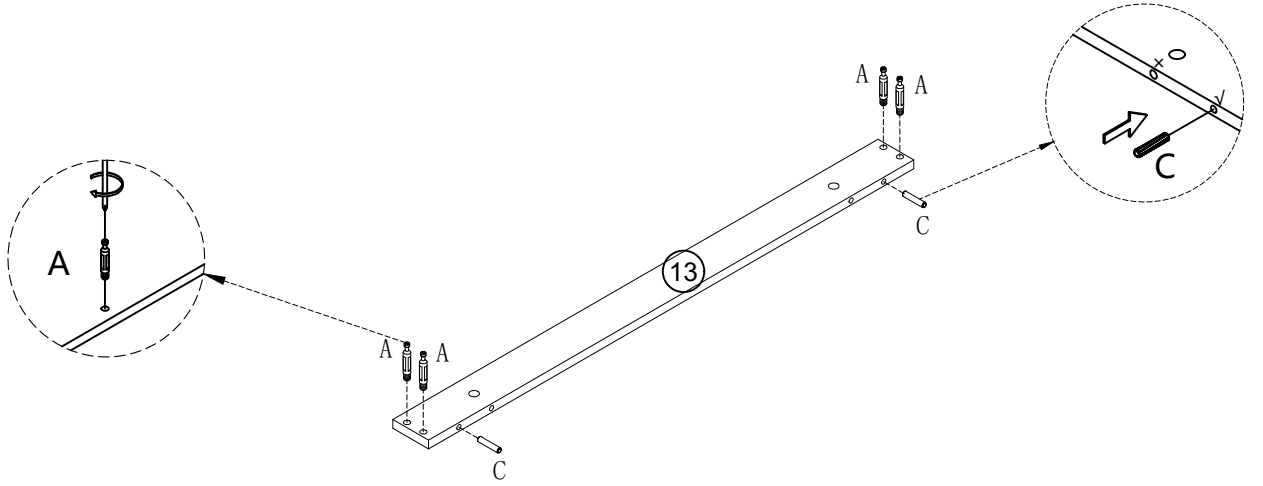

X2



Ax8pcs



Cx4pcs

Step 2

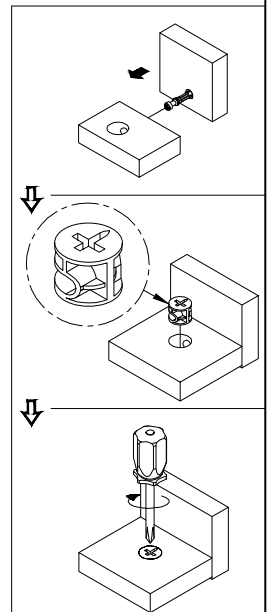
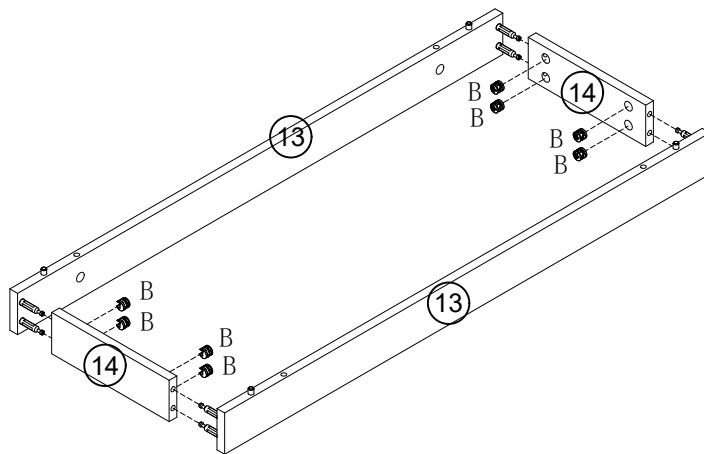

Bx8pcs

Step 3

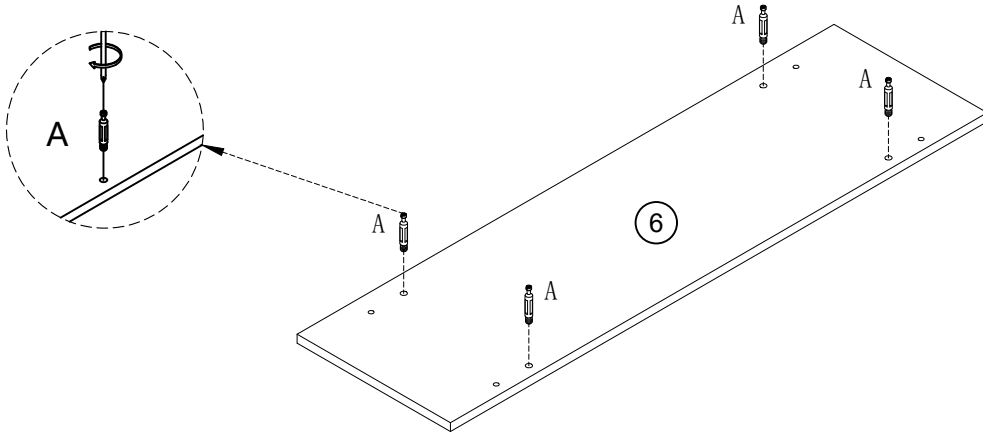

Ax4pcs

Step 4

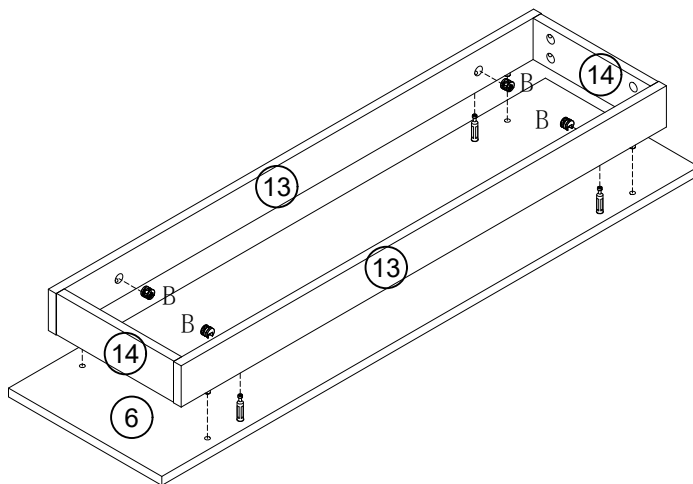

Bx4pcs

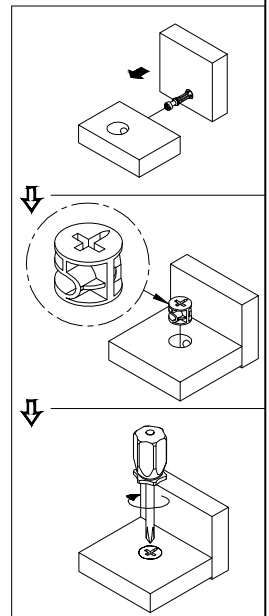

Step 5

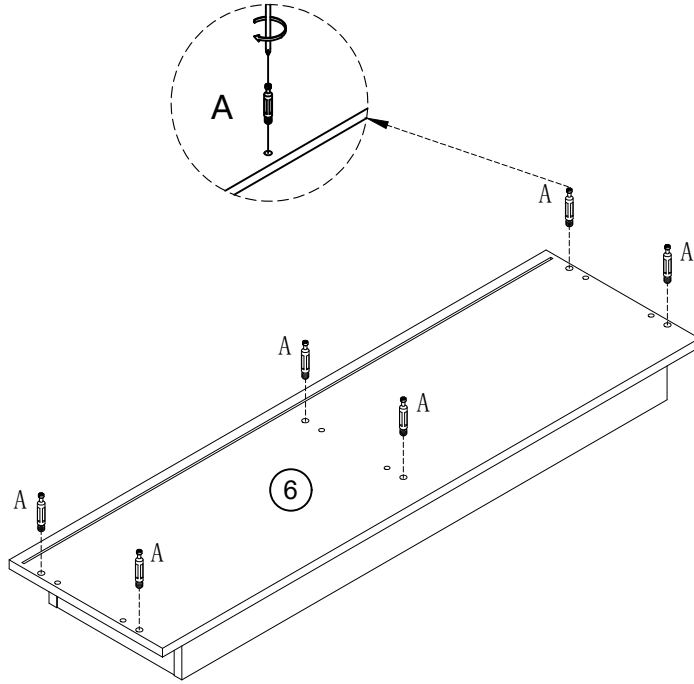

Ax6pcs

Step 6

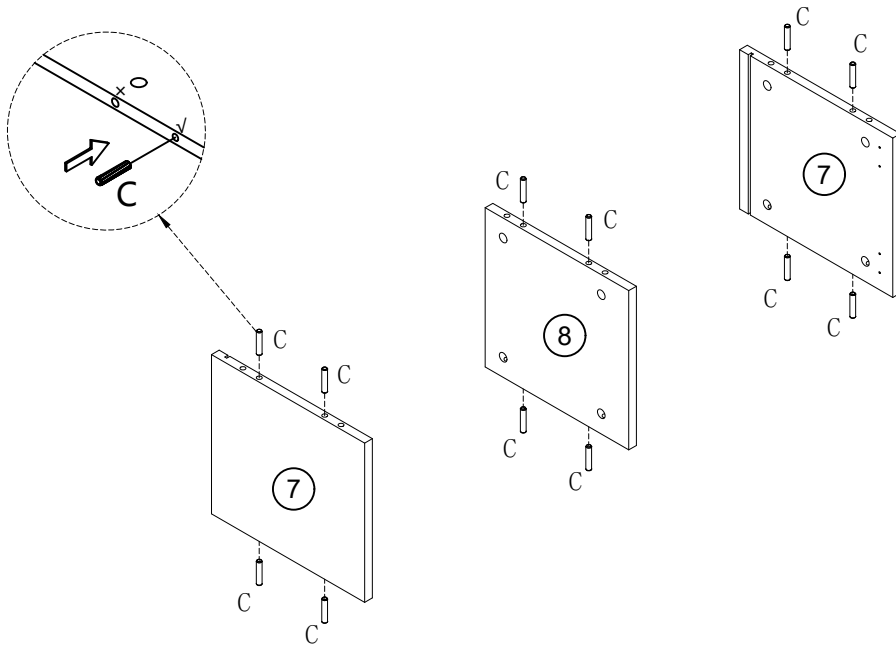

Cx12pcs

Step 7

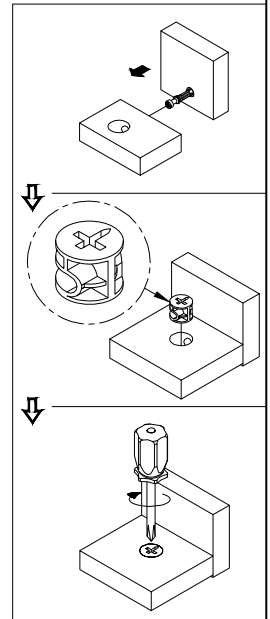
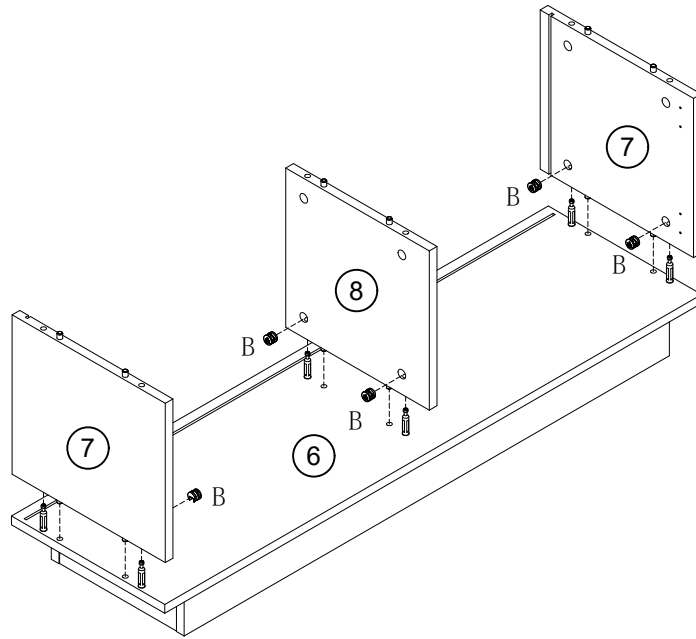

 Bx6pcs

Step 8

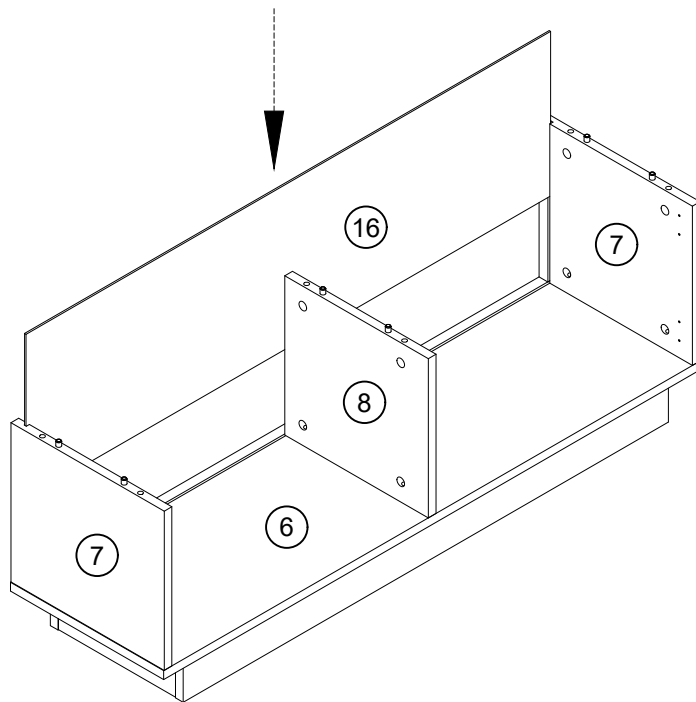

Step 9

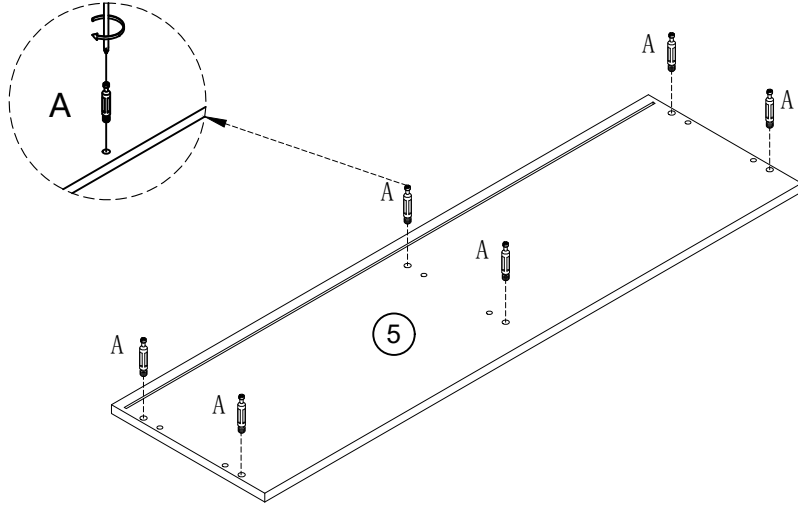

Ax6pcs

Step 10

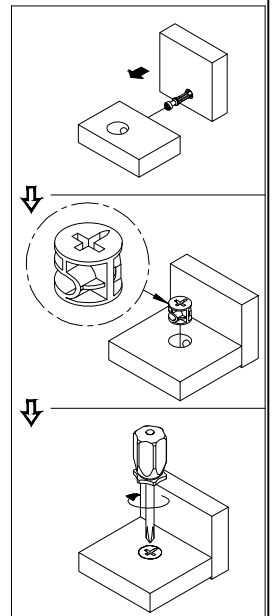
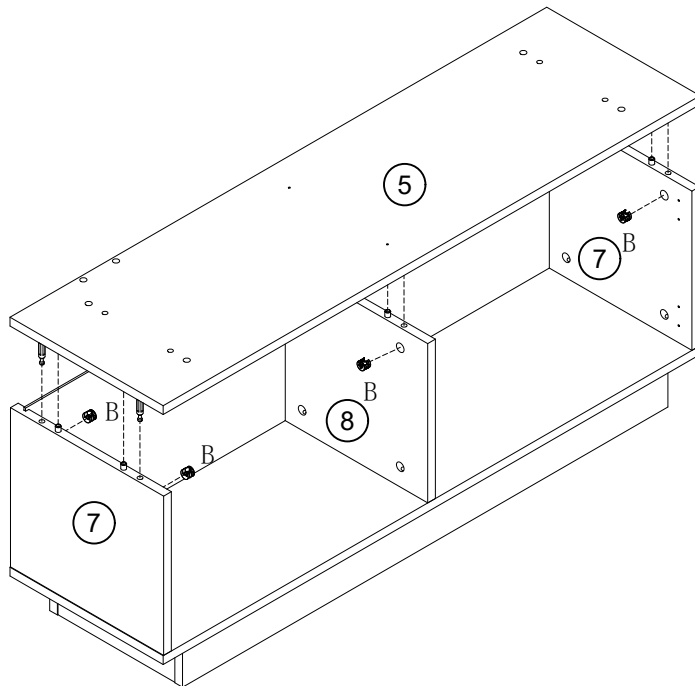

Bx6pcs

Step 11

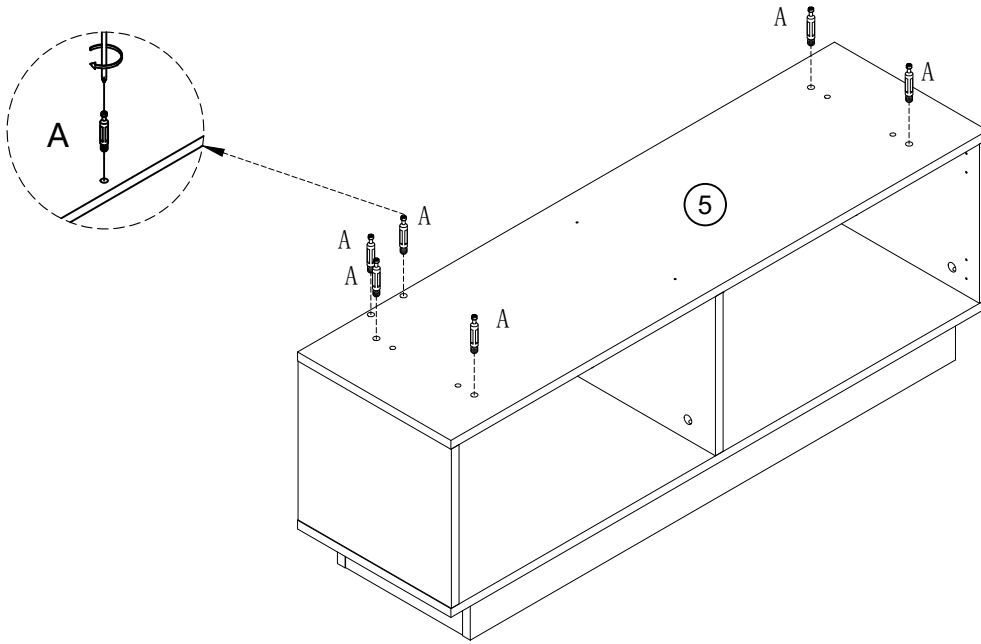

Ax6pcs

Step 12

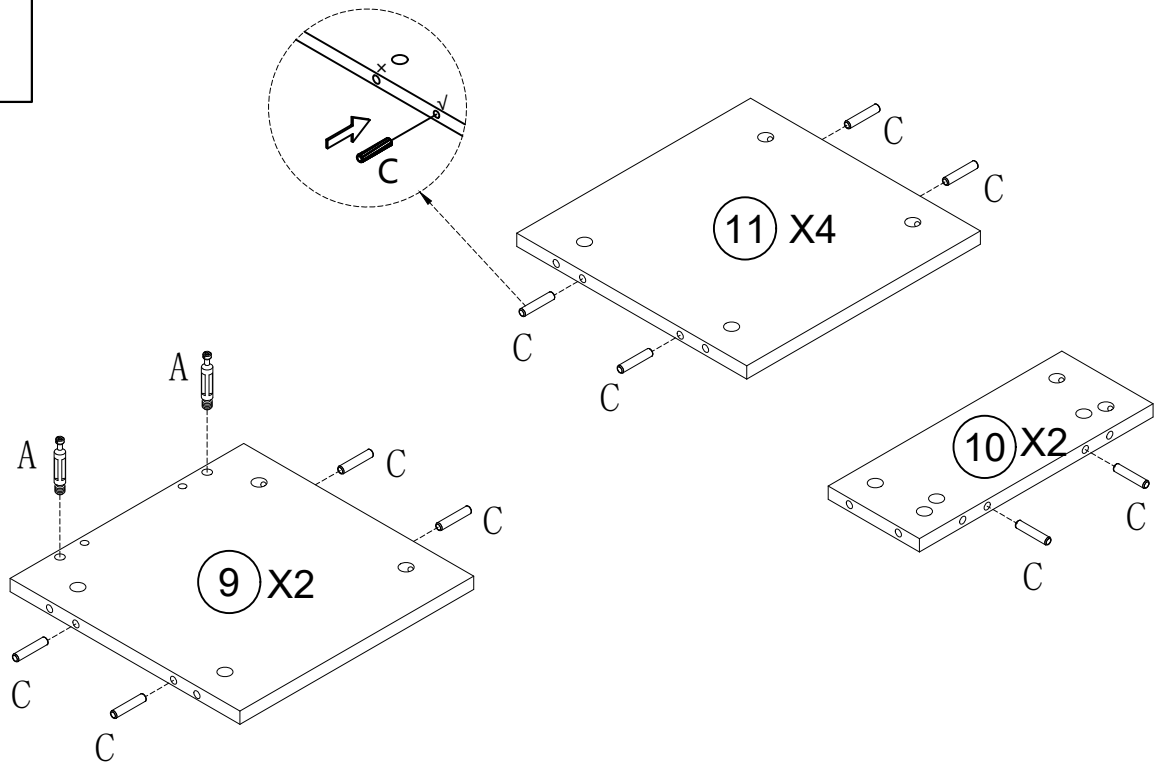



Ax4pcs

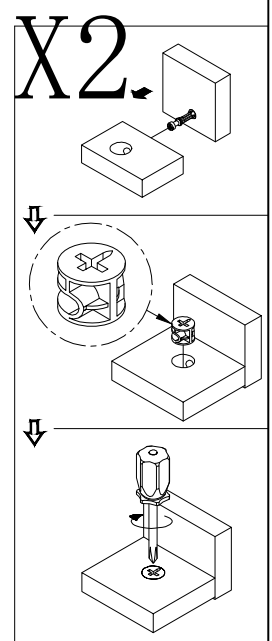
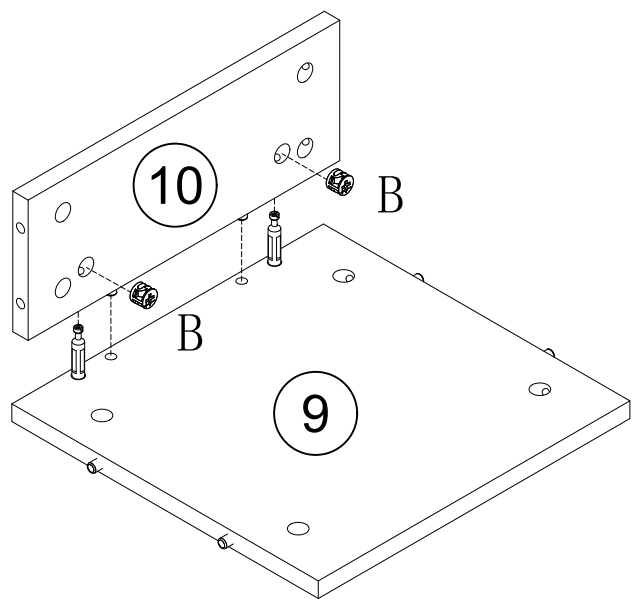

Cx28pcs

Step 13



 Bx4pcs

Step 14

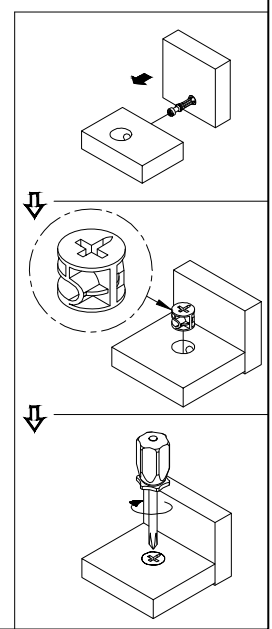
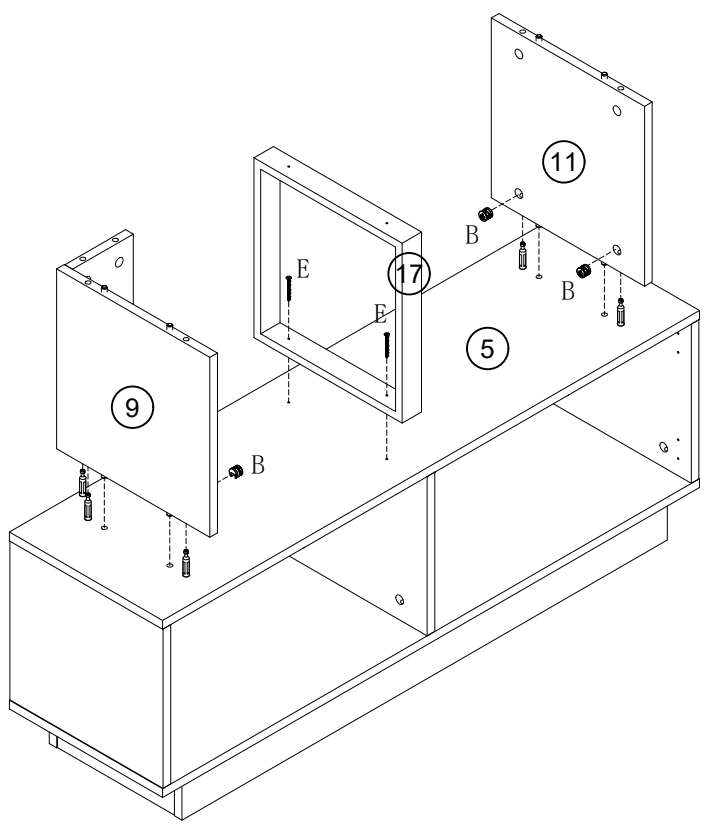

 Bx6pcs

 Ex2pcs

Step 15

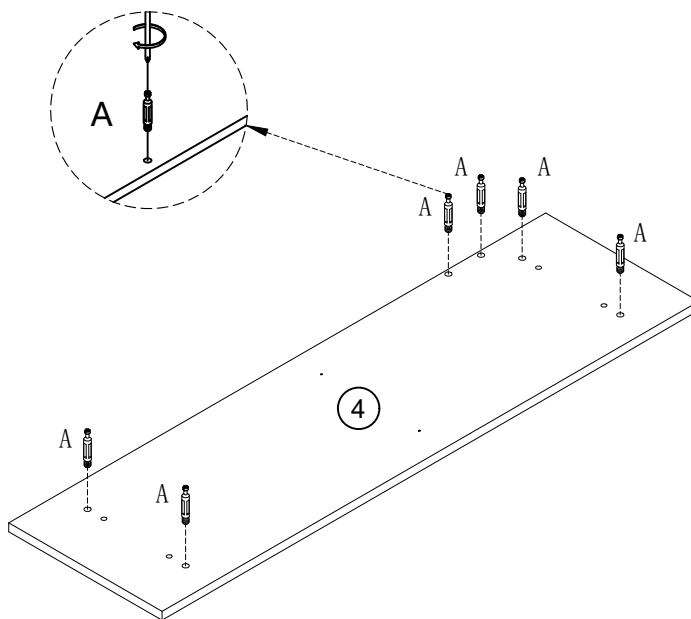

Ax6pcs

Step 16

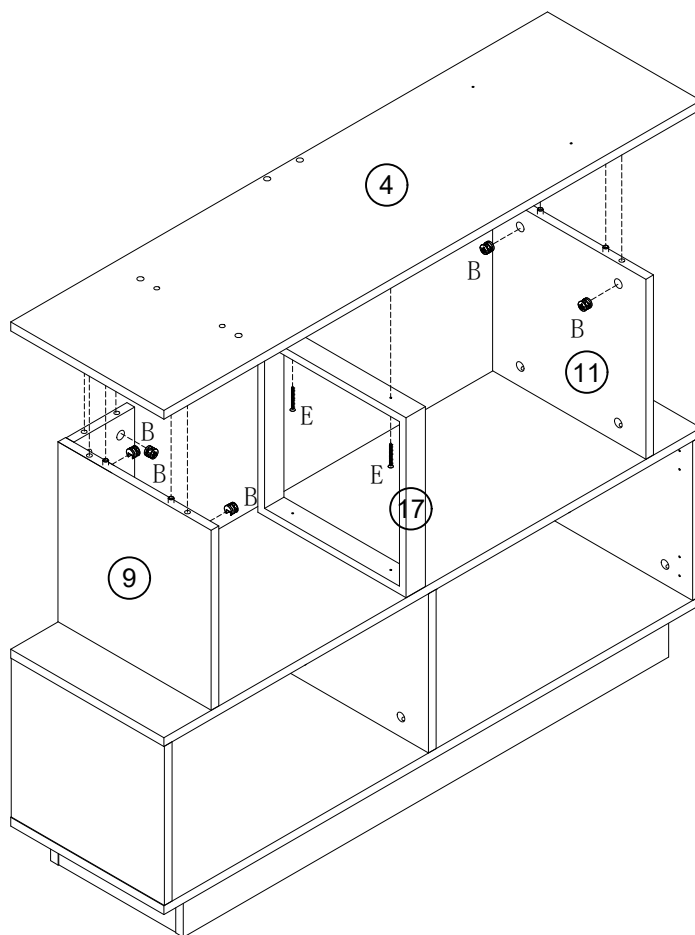

Bx6pcs



Ex2pcs

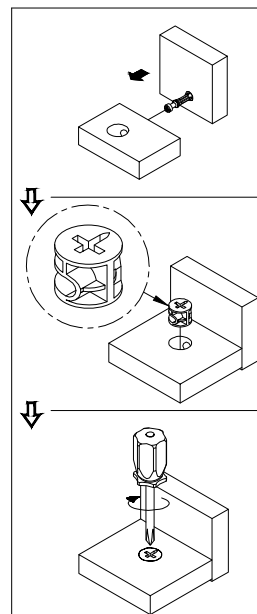

Step 17

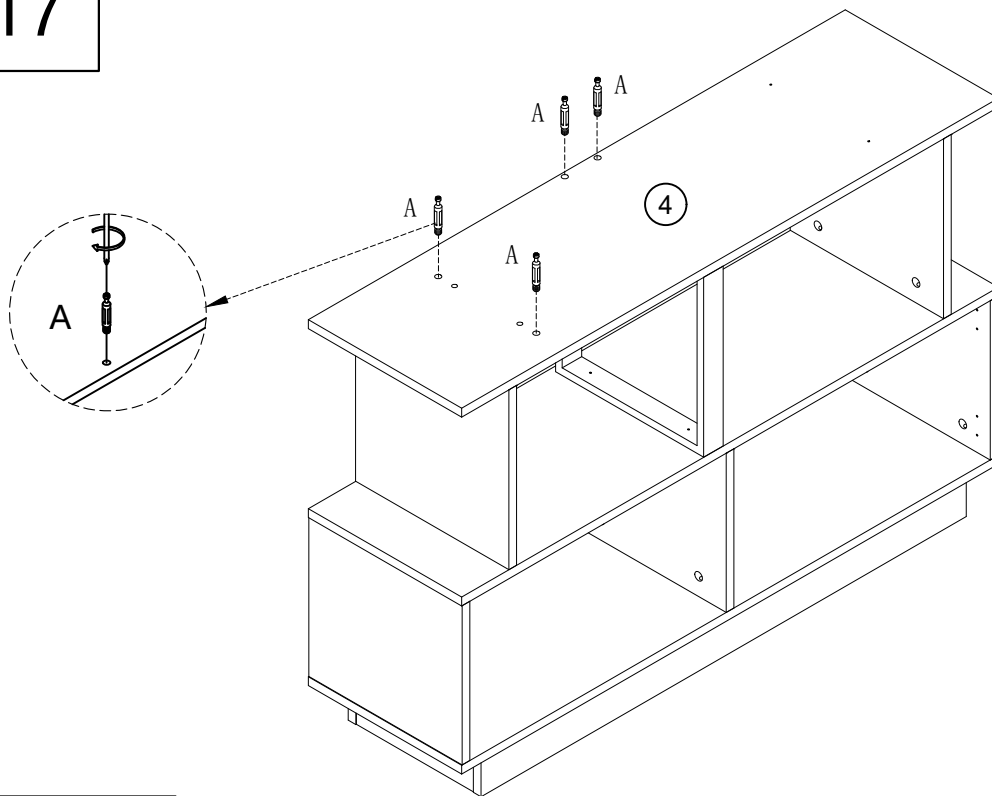

Ax4pcs

Step 18

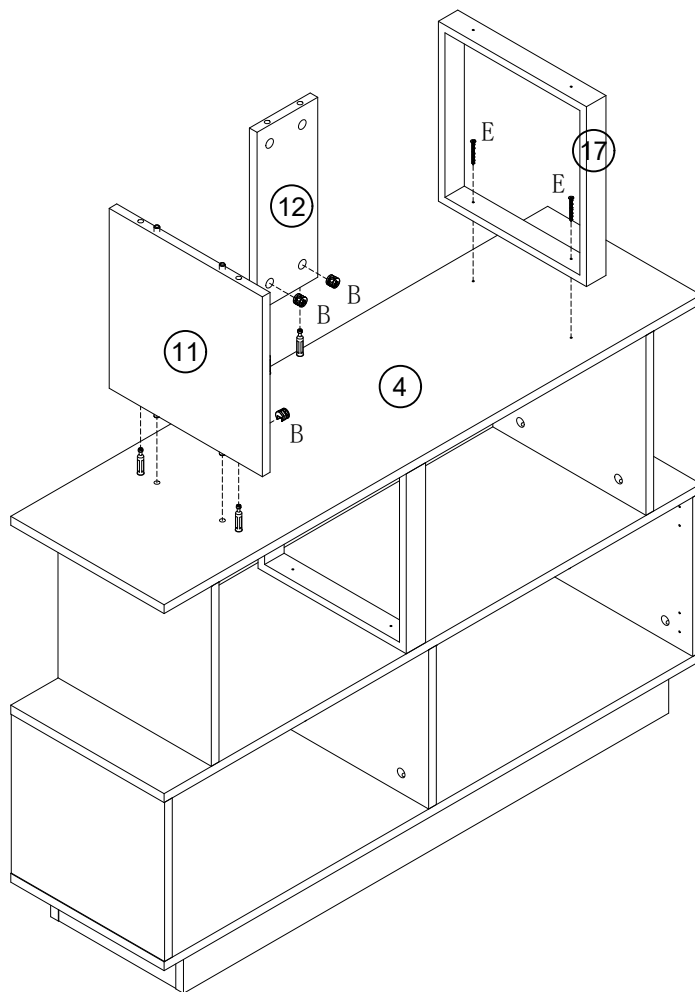

Bx4pcs



Ex2pcs

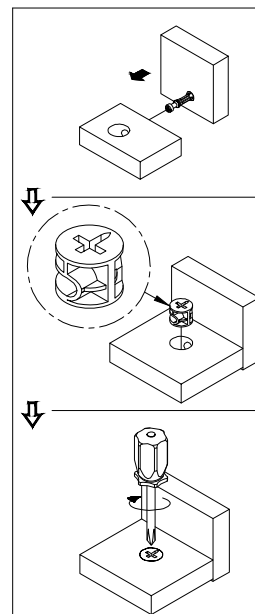

Step 19

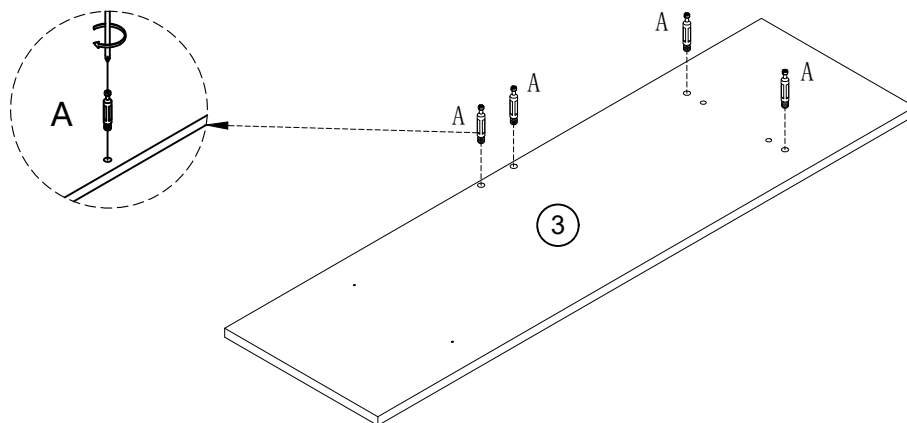

Ax4pcs

Step 20

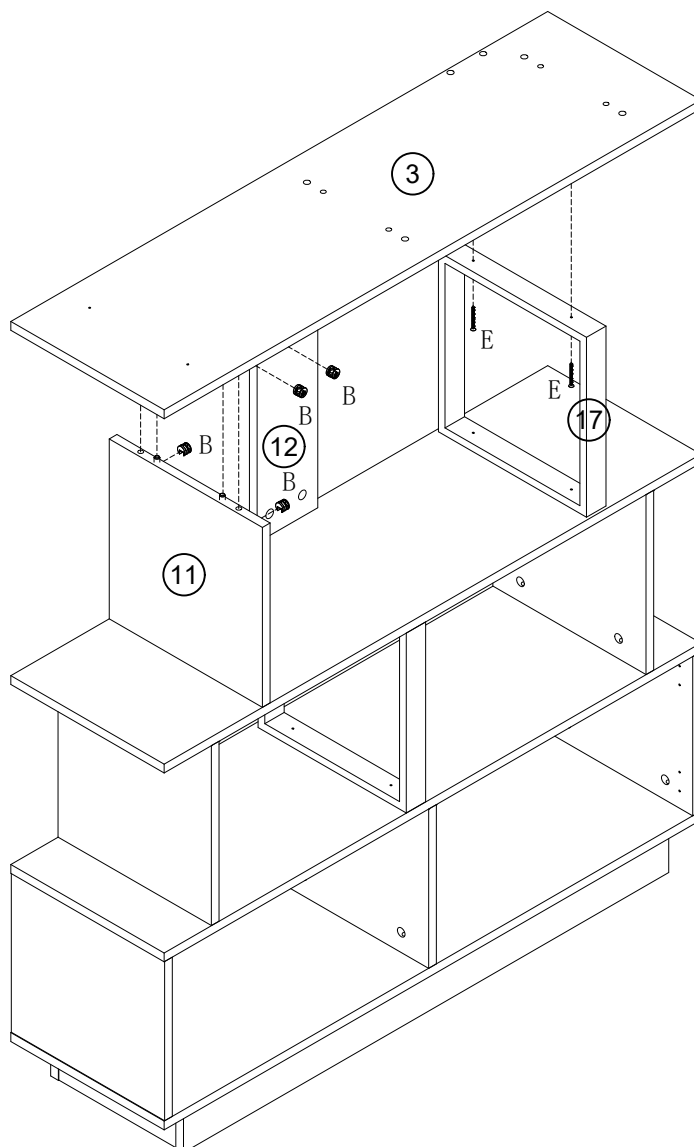

Bx4pcs



Ex2pcs

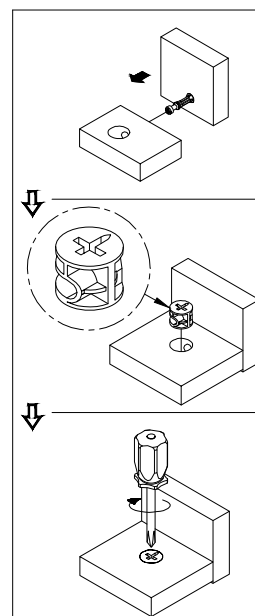

Step 21

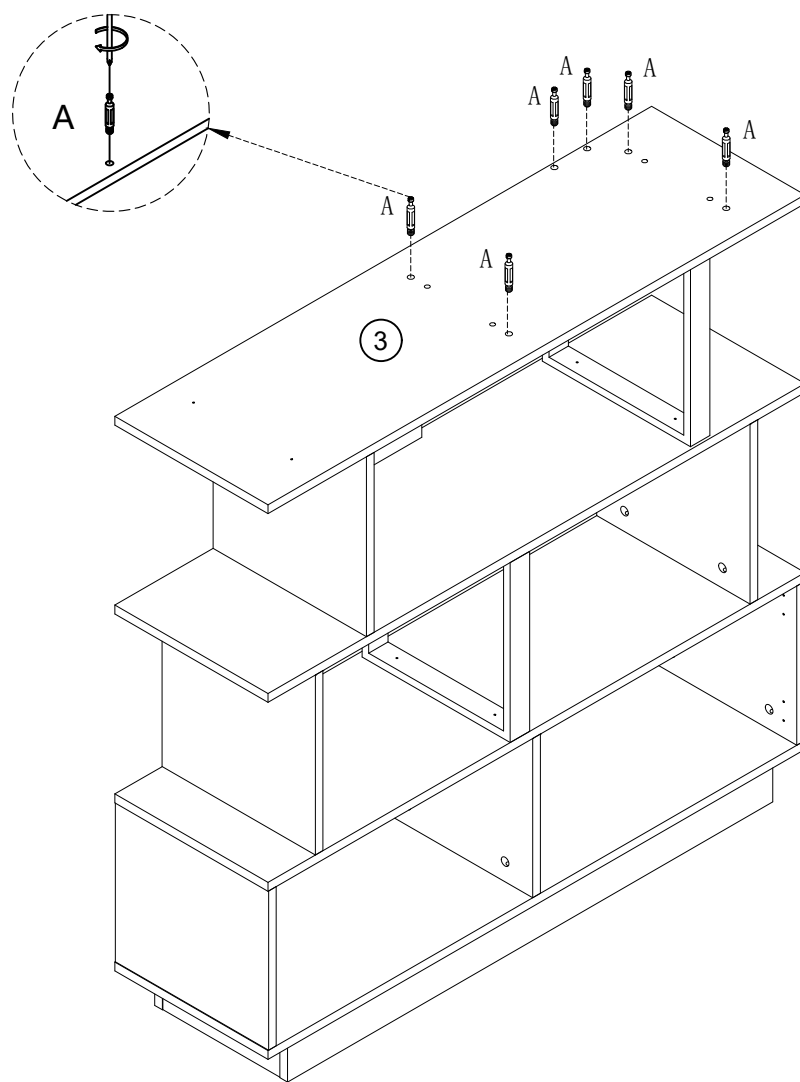

Ax6pcs

Step 22

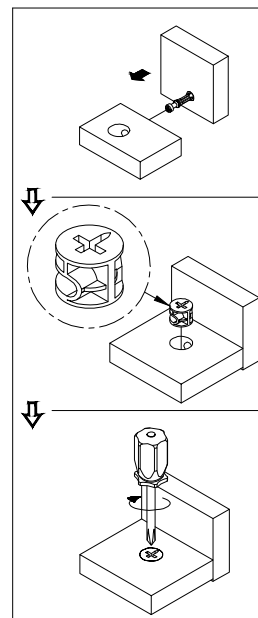
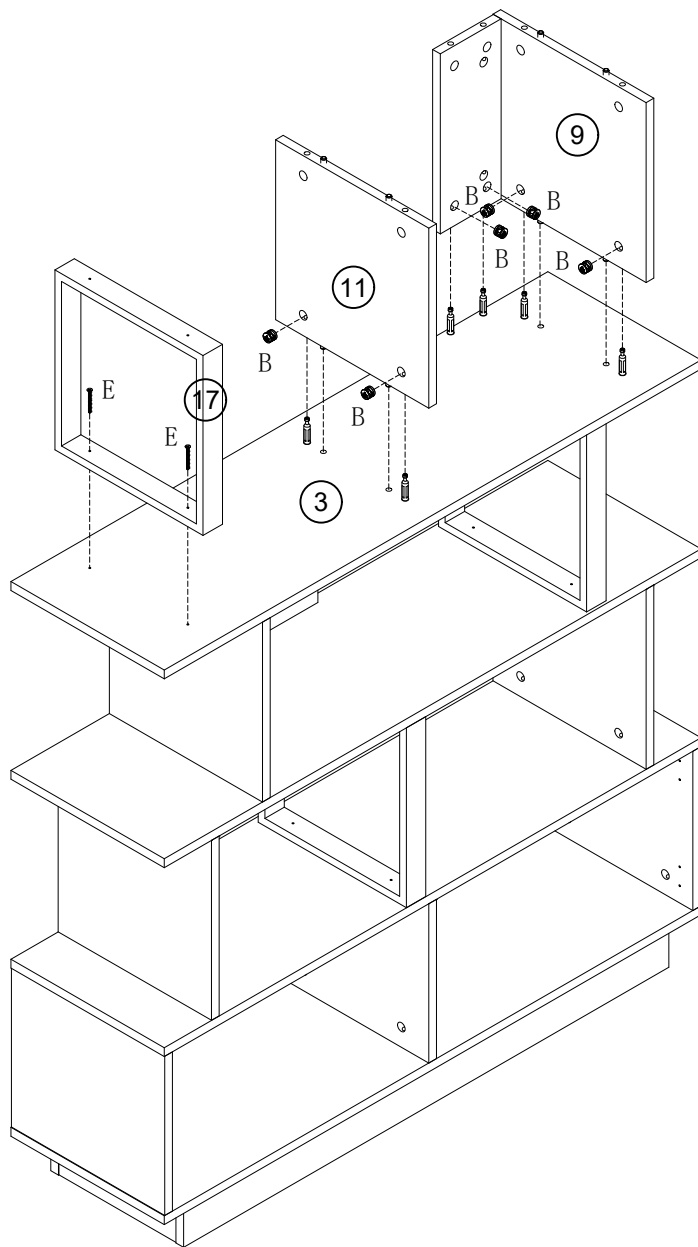

Bx6pcs



Ex2pcs

Step 23

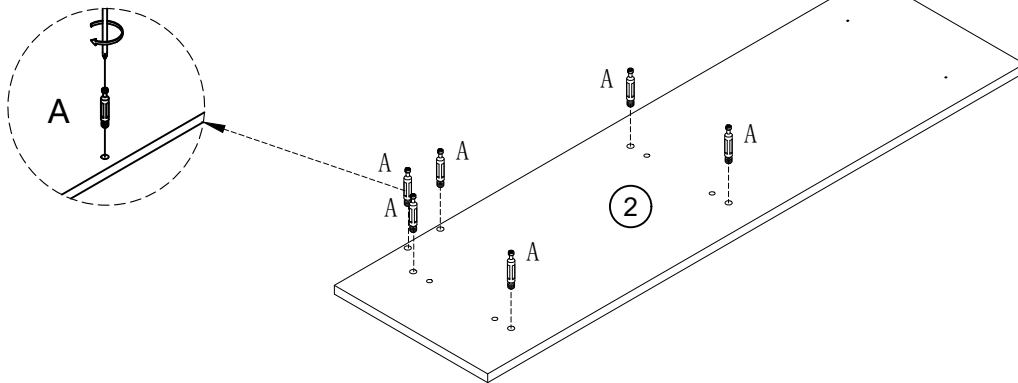

Ax6pcs

Step 24

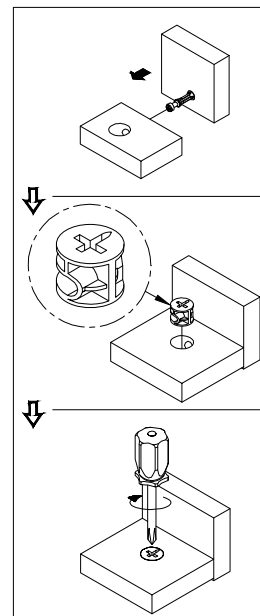
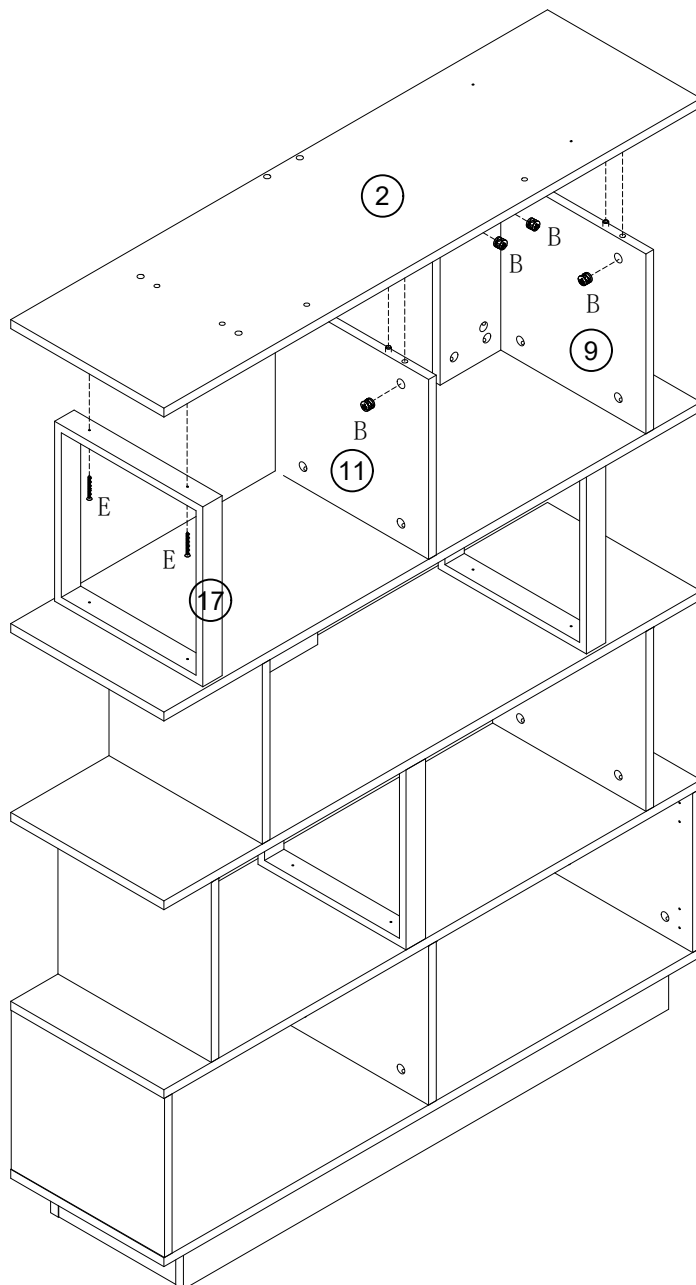

Bx6pcs



Ex2pcs

Step 25

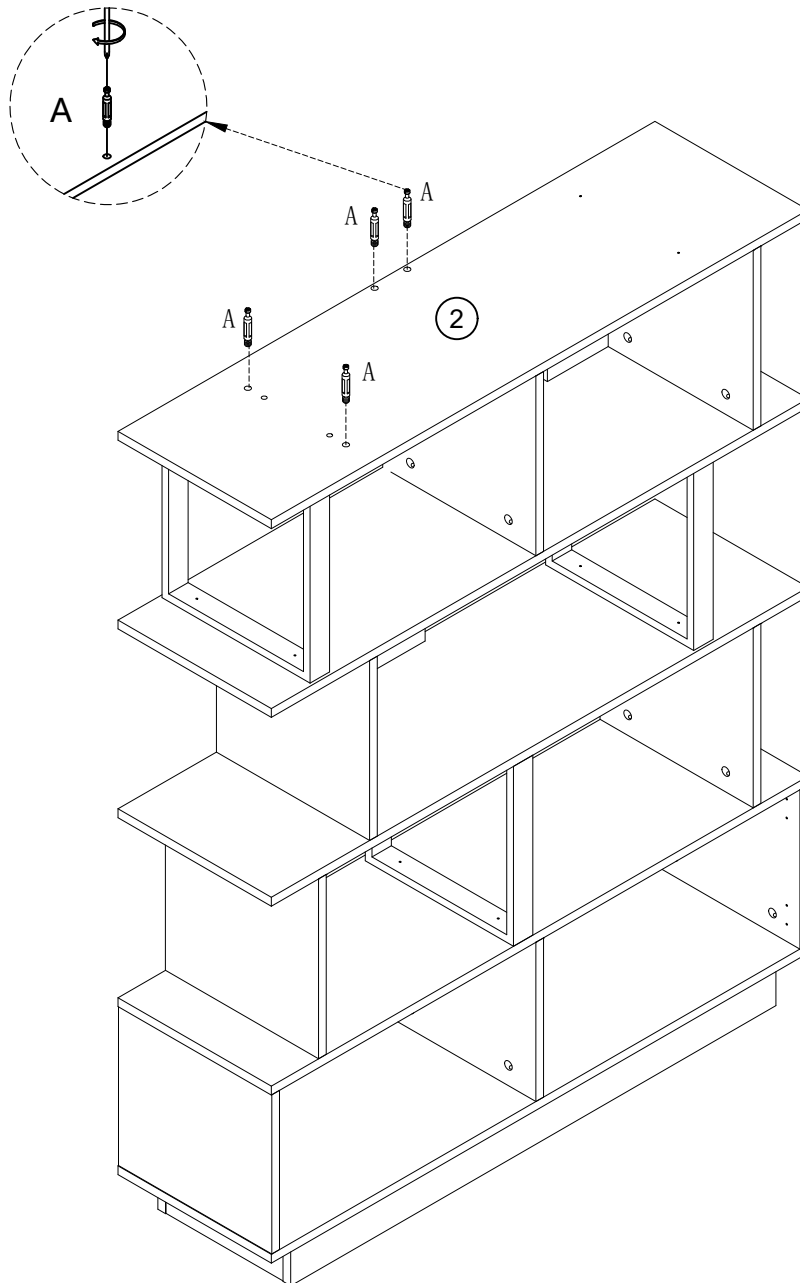

Ax4pcs

Step 26

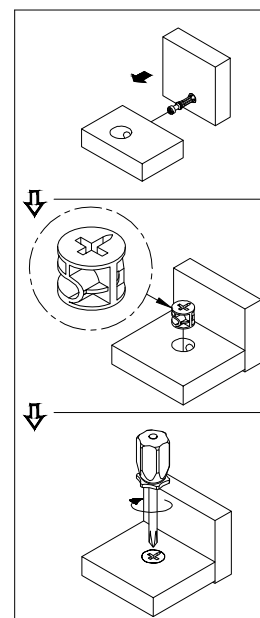
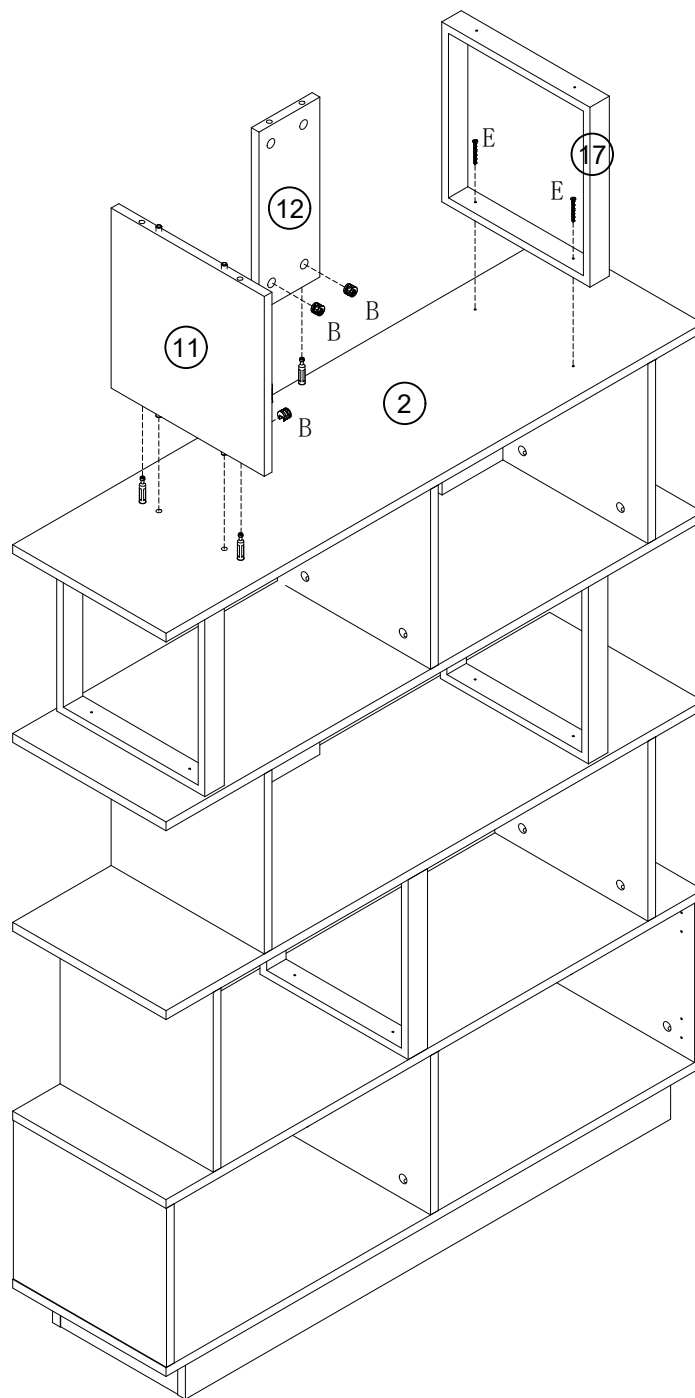

Bx4pcs



Ex2pcs

Step 27

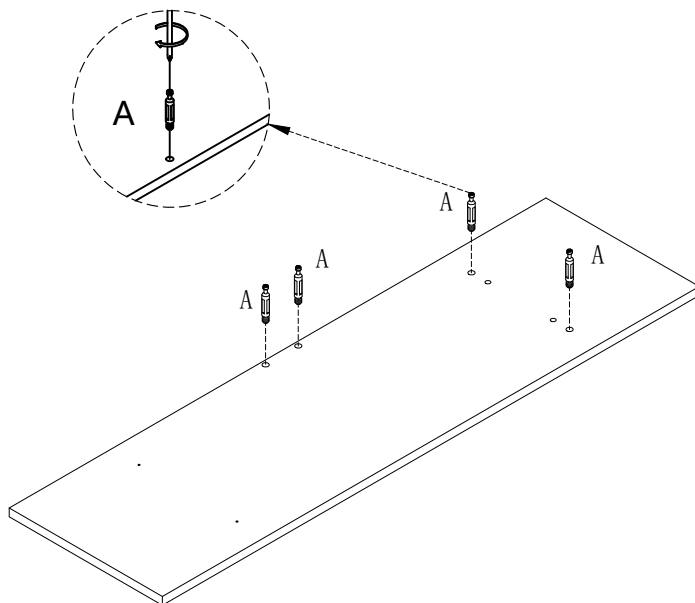

Ax4pcs

Step 28

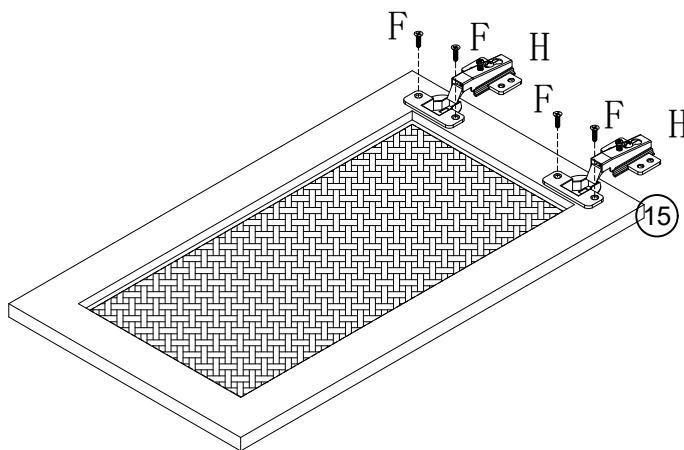

Fx8pcs





Hx4pcs

X2

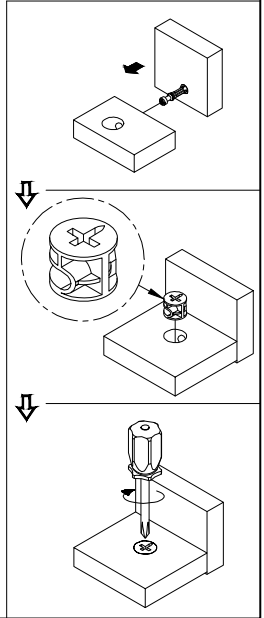
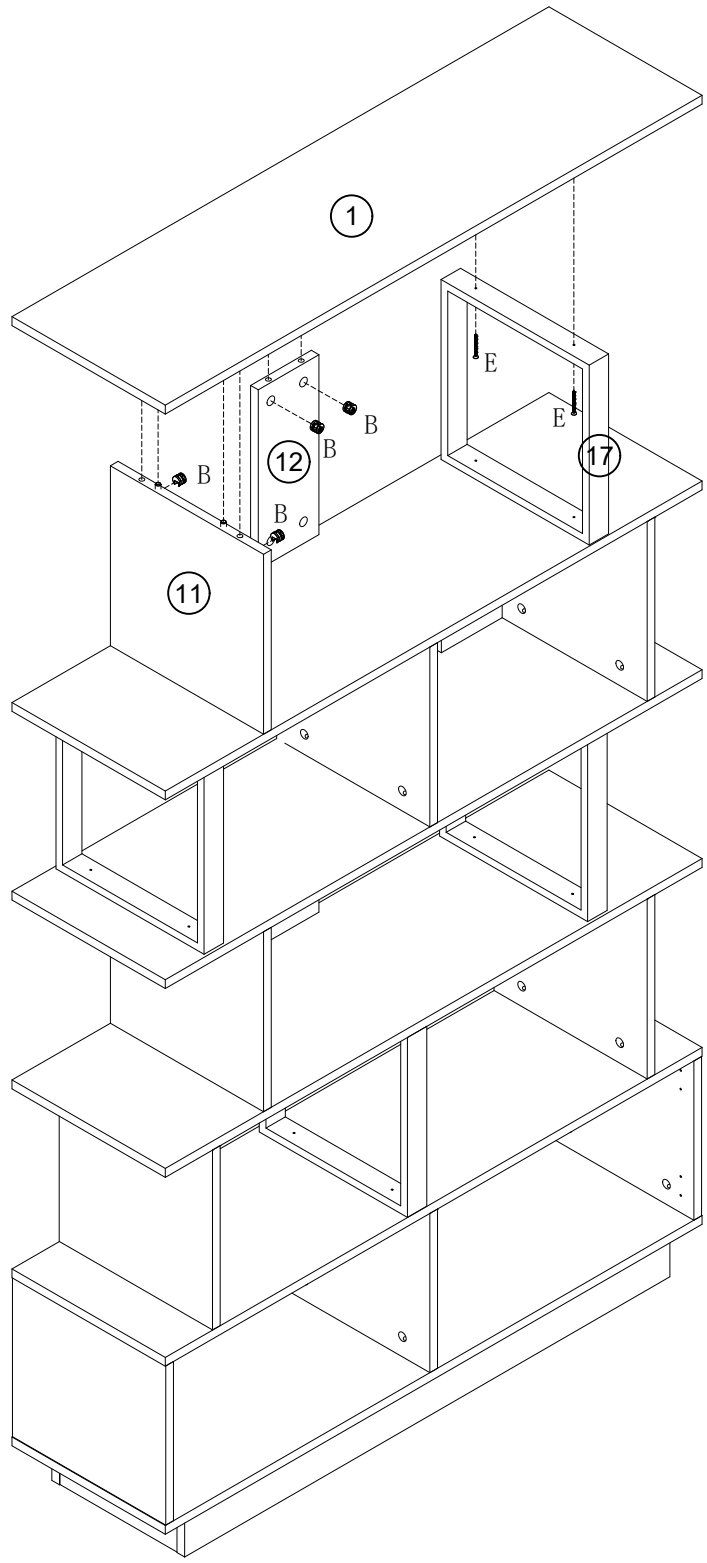
Step 29



	Bx4pcs
	Ex2pcs

Step 30

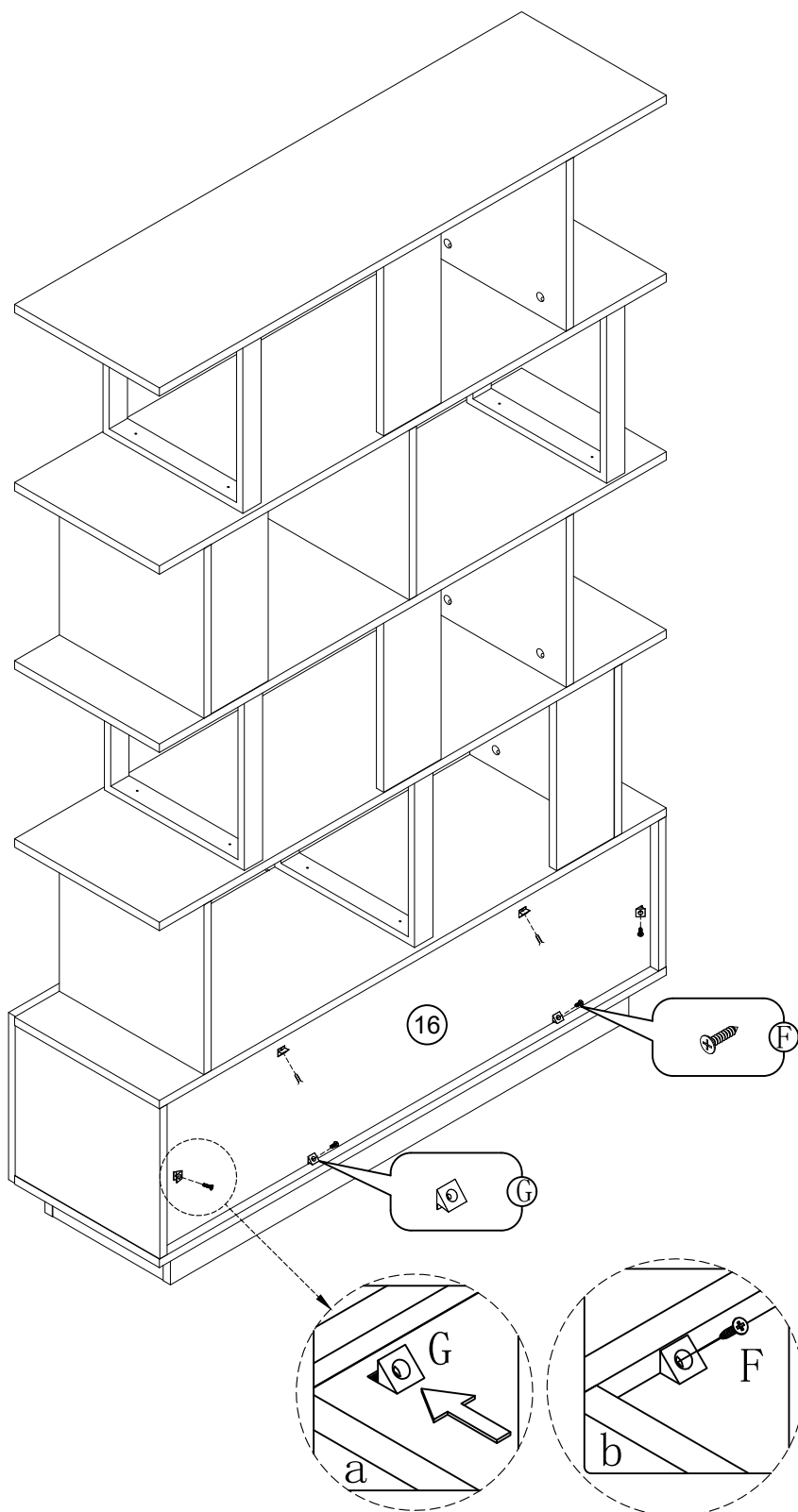

Fx6pcs



Gx6pcs

Step 31

EN:Note: Please assemble the door according to the installation steps first. If the cabinet door is deviated, the internal hinge needs to be slowly adjusted to solve the problem.

DE:Hinweis: Bitte montieren Sie die Tür zunächst gemäß den Installationsschritten. Wenn die Schranktür abweicht, muss das innere Scharnier langsam angepasst werden, um das Problem zu lösen.

FR:Remarque : Veuillez d'abord assembler la porte en suivant les étapes d'installation. Si la porte de l'armoire est déviée, la charnière interne doit être ajustée lentement pour résoudre le problème.

ES:Nota: Primero, ensamble la puerta de acuerdo con los pasos de instalación. Si la puerta del gabinete está desviada, la bisagra interna debe ajustarse lentamente para resolver el problema.

IT:Nota: si prega di montare prima la porta seguendo i passaggi di installazione. Se la porta dell'armadio è deviata, la cerniera interna deve essere regolata lentamente per risolvere il problema.

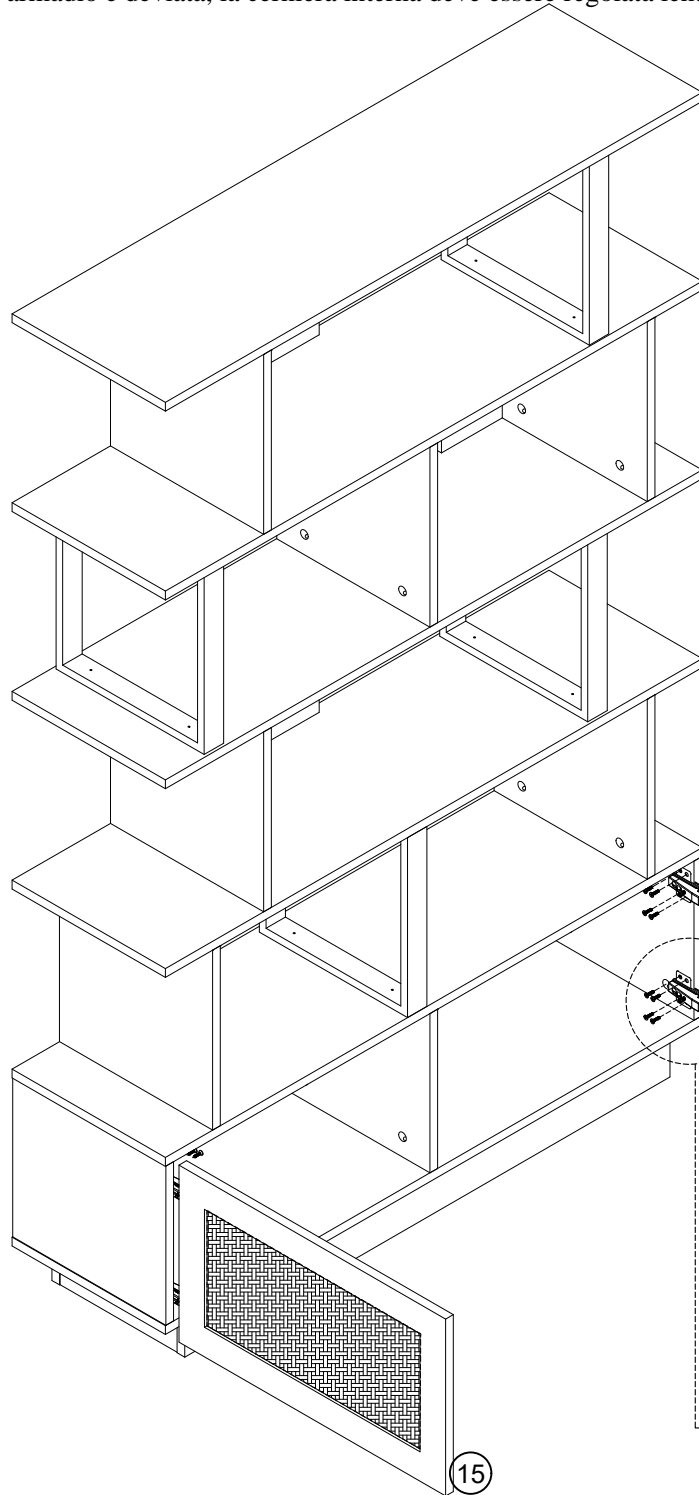

EN:In order to make the product more beautiful, please paste hardware D on the exposed holes
 DE:Um das Produkt schöner zu machen, kleben Sie bitte die Hardware D auf die freiliegenden Löcher

FR:Afin de rendre le produit plus beau, veuillez coller le matériel D sur les trous exposés

ES:Para que el producto sea más bonito, pegue el hardware D en los orificios expuestos.

IT : Per rendere il prodotto più bello, si prega di incollare l'hardware D sui fori esposti

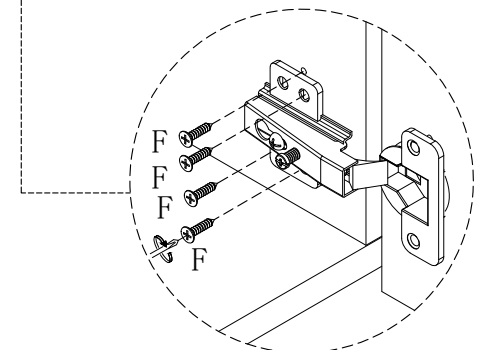
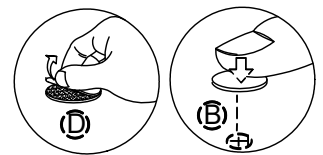

Fx16pcs



Dx68pcs

If the door can't close, please adjust the hinges.

Step 32

EN:To adjust the door verticallyloosen the screw as shownand move up and down as needed.

DE:Um die Tür vertikal einzustellen, lösen Sie die Schraube wie gezeigt und bewegen Sie sie nach Bedarf nach oben und unten.

FR:Pour régler la porte verticalement, desserrez la vis comme indiqué et déplacez-la de haut en bas selon vos besoins.

ES:Para ajustar la puerta verticalmente, afloje el tornillo como se muestra y muévalo hacia arriba y hacia abajo según sea necesario.

IT:Per regolare la porta verticalmente, allentare la vite come mostrato in figura e muoverla verso l'alto e verso il basso secondo necessità.

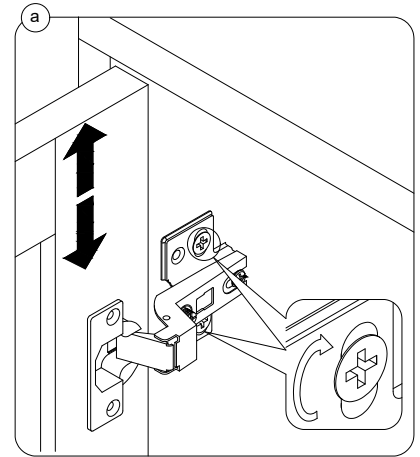

EN:To adjust the gap from the door to the main frame turn thescrew clockwise or anti-clockwise as needed.

DE:Um den Abstand zwischen der Tür und dem Hauptrahmen anzupassen, drehen Sie die Schraube je nach Bedarf im oder gegen den Uhrzeigersinn.

FR:Pour régler l'espace entre la porte et le cadre principal, tournez la vis dans le sens des aiguilles d'une montre ou dans le sens inverse des aiguilles d'une montre selon vos besoins.

ES:Para ajustar el espacio entre la puerta y el marco principal, gire el tornillo en el sentido de las agujas del reloj o en el sentido contrario a las agujas del reloj según sea necesario.

IT:Per regolare la distanza tra la porta e il telaio principale, ruotare la vite in senso orario o antiorario, a seconda delle necessità.

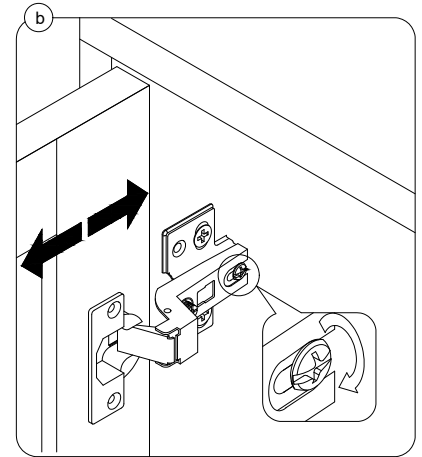

EN:To adjust the door laterally adjust the screw as shown byturning clockwise or anti-clockwise.

DE:Um die Tür seitlich auszurichten, verstellen Sie die Schraube wie gezeigt durch Drehen im oder gegen den Uhrzeigersinn.

FR:Pour régler la porte latéralement, ajustez la vis comme indiqué en tournant dans le sens des aiguilles d'une montre ou dans le sens inverse des aiguilles d'une montre.

ES:Para ajustar la puerta lateralmente, ajuste el tornillo como se muestra girándolo en el sentido de las agujas del reloj o en el sentido contrario a las agujas del reloj.

IT:Per regolare lateralmente la porta, regolare la vite come mostrato, ruotandola in senso orario o antiorario.

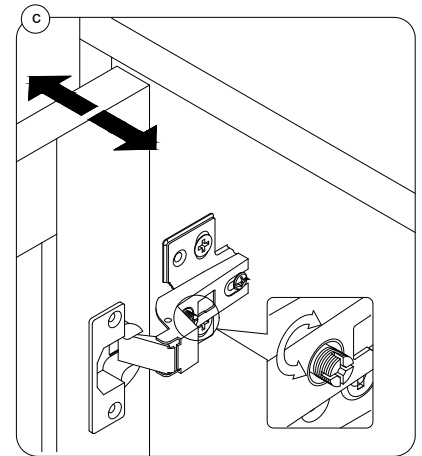

EN:Please fix other screws

DE:Bitte andere Schrauben anziehen

FR:Veuillez fixer les autres vis

ES:Por favor, arregle los otros tornillos.

IT:Per favore, fissa le altre viti

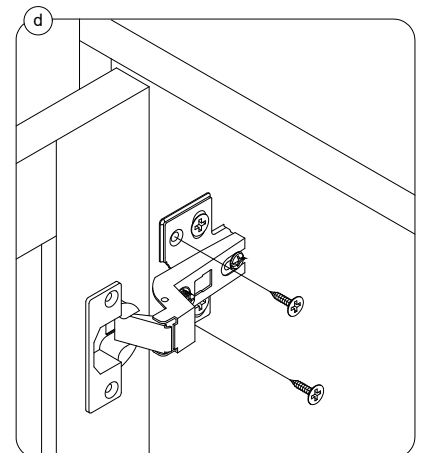

Step 33

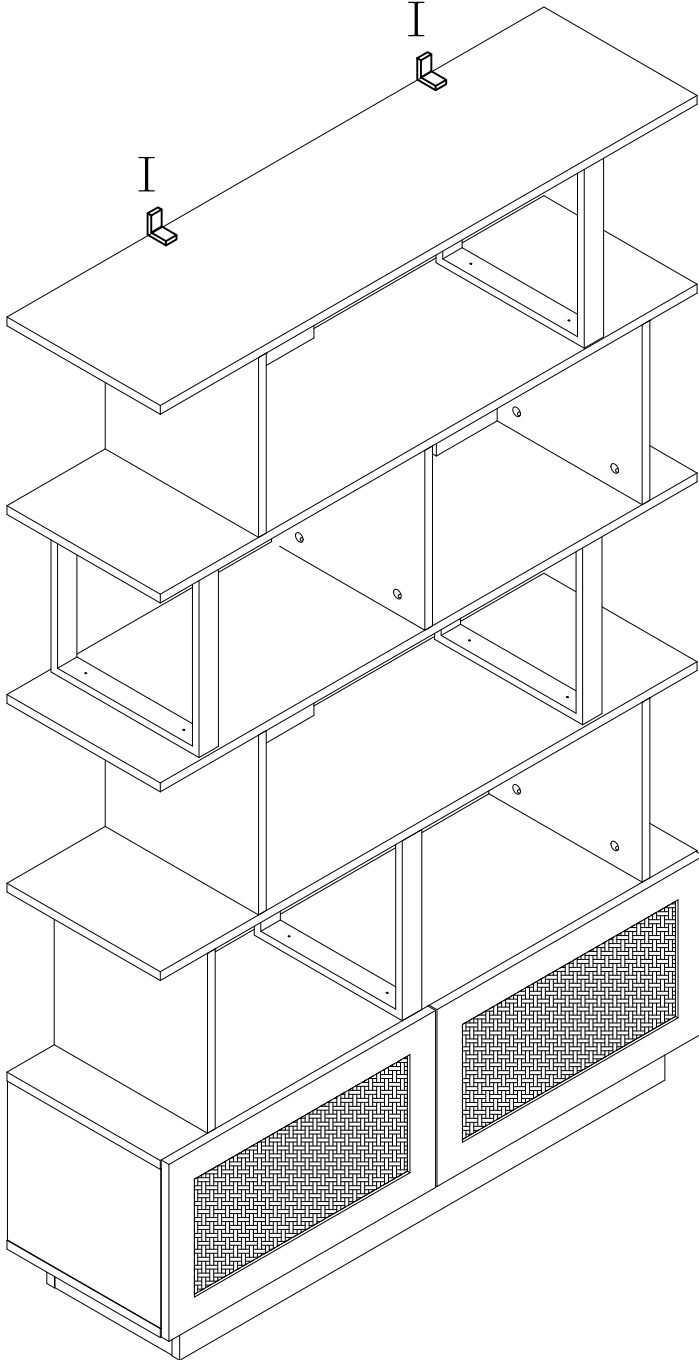
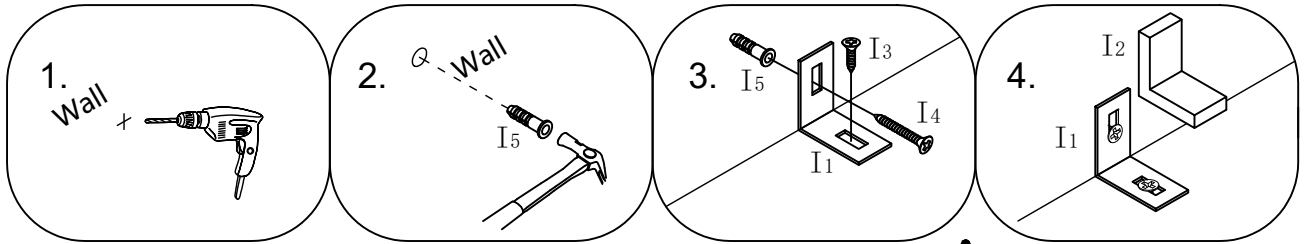

EN: Warning: Before drilling, check wall for hidden pipes and cables.
 DE: Achtung: Überprüfen Sie vor dem Bohren die Wand auf versteckte Rohre und Kabel.
 FR: Avertissement : avant de percer, vérifiez que le mur ne présente pas de tuyaux ou de câbles cachés.
 ES: Advertencia: Antes de perforar, revise la pared para ver si hay tuberías y cables ocultos.
 IT: Attenzione: prima di forare, controllare che non vi siano tubi o cavi nascosti nel muro.

EN: The unit is floor standing, but it is recommended that the unit is secured to the wall.

1. Move the unit into desired position.
2. Mark the wall with a suitable scribe the position of the fixing holes.
3. Drill holes and insert 2 x wall plug

DE: Das Gerät ist bodenstehend, es wird jedoch empfohlen, es an der Wand zu befestigen.

1. Bewegen Sie das Gerät in die gewünschte Position.
2. Markieren Sie mit einem geeigneten Reißnagel die Position der Befestigungslöcher an der Wand.
3. Bohren Sie Löcher und setzen Sie 2 x Dübel ein

FR: L'unité est posée au sol, mais il est recommandé de la fixer au mur.





1. Déplacez l'unité dans la position souhaitée.
2. Marquez sur le mur avec un scribe approprié la position des trous de fixation.
3. Percez des trous et insérez 2 chevilles murales

ES: La unidad se coloca sobre el piso, pero se recomienda fijarla a la pared.

1. Mueva la unidad a la posición deseada.
2. Marque en la pared con un punzón adecuado la posición de los orificios de fijación.
3. Taladre orificios e inserte 2 tacos de pared

IT: L'unità è appoggiata al pavimento, ma si consiglia di fissarla alla parete.

1. Spostare l'unità nella posizione desiderata.
2. Segnare la parete con un apposito scribe la posizione dei fori di fissaggio.
3. Praticare i fori e inserire 2 tasselli a muro

	I ₁ x2pcs		I ₃ x2pcs		
	I ₂ x2pcs		I ₄ x2pcs		I ₅ x2pcs

Step 34

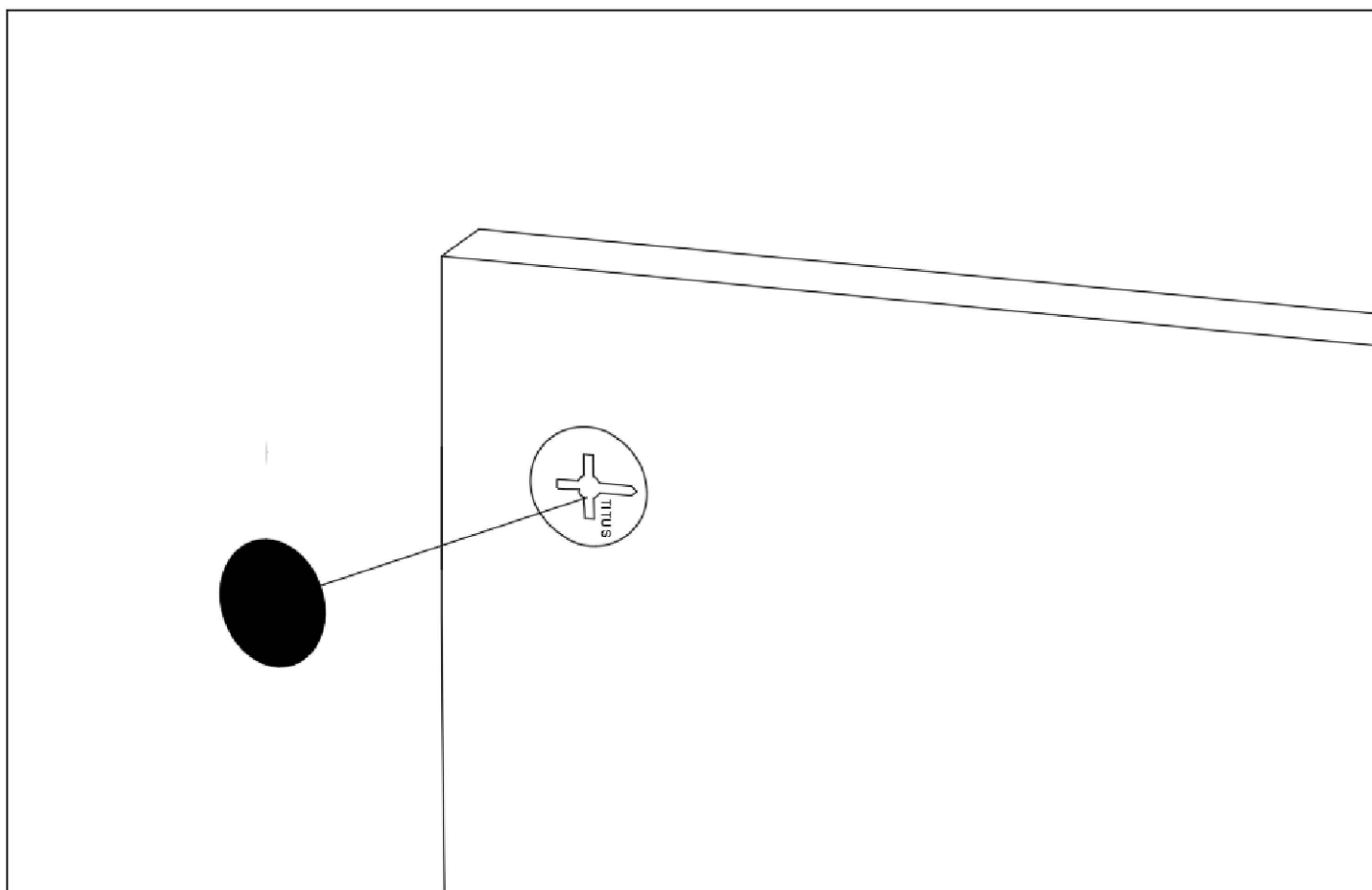

EN: After installing the product, stick the number D on the perforated position

FR: Une fois le produit installé, collez le numéro D à l'endroit où il y a des trous

DE: Nach der Installation des Produkts kleben Sie die Nummer D auf die perforierte Position

IT:Dopo l'installazione del prodotto, fissare il numero D sulla posizione perforata

ES:Después de instalar el producto, pegue el número D en la posición perforada



D x 68 pcs